

WARHAMMER®

40,000



In the grim darkness of the far future there is only war.

WARHAMMER®

40,000



IN THE GRIM DARKNESS OF THE
FAR FUTURE THERE IS ONLY WAR



Being in part an exposition of the Warhammer 40,000 game
wherein opposing players assume command of miniature armies
to recreate upon the tabletop the savage battles of a future age.



Proceed at Your own Peril



For more than a hundred centuries the Emperor has sat immobile on the Golden Throne of Earth. He is the master of mankind by the will of the gods and master of a million worlds by the might of his inexhaustible armies. He is a rotting carcass writhing invisibly with power from the Dark Age of Technology. He is the Carrion Lord of the Imperium for whom a thousand souls die every day, for whom blood is drunk and flesh eaten. Human blood and human flesh – the stuff of which the Imperium is made.



To be a man in such times is to be one amongst untold billions. It is to live in the cruellest and most bloody regime imaginable. This is the tale of those times. It is a universe you can live in today – if you dare – for this is a dark and terrible era where you will find little comfort or hope. If you want to take part in the adventure then prepare yourself now. Forget the power of technology, science and common humanity. Forget the promise of progress and understanding, for there is no peace amongst the stars, only an eternity of carnage and slaughter and the laughter of thirsting gods.



But the universe is a big place and, whatever happens, you will not be missed...

WARHAMMER®

40,000

Game Design & Development:

Rick Priestley, Andy Chambers, Gavin Thorpe, Ian Pickstock & Jervis Johnson.

Assistant Games Developers:

Iain Compton, Andy Kettlewell & Warwick Kinrade.

Editors:

Lindsey Priestley, Talima Fox & Jake Thornton.

Cover painting:

John Blanche.

Illustrators:

John Blanche, Alex Boyd, Wayne England, David Gallagher, Des Hanley, Neil Hodgson, Nuala Kennedy, Paul Smith, John Wigley & Richard Wright.

Citadel Designers:

Tim Adcock, Dave Andrews, Colin Dixon, Chris Fitzpatrick, Jes Goodwin, Gary Morley, Aly Morrison, Trish Morrison, Paul Muller, Brian Nelson, Alan Perry, Michael Perry & Norman Swales.

Wargames Terrain Modellers:

Owen Branham, Mark Bedford & Mark Jones.

Miniatures Painters:

Stuart Thomas, Ben Jefferson, Martin Footitt, Chris Smart, Richard Baker, David Thomas, Dave Perry, Torben Schnoor, Neil Green & Adrian Walters.

Production:

Alan Merrett, Chris Colston, Jim Butler, Matt White, Mark Saunders, Nick Davis, Simon Burton, Andy Banks, Steve Averill, Simon Smith, Andy Bacon & Owen Crisp.

Photography:

Anthony Bath.

Thanks to:

Robin Dews, Tom Kirby, John Stallard, Gordon Davidson, Adrian Wood, Pete Haines, Jim Cash, Fred Reed, Tuomas Pirinen, Ben Marlow, Tim Huckleberry, Jeremy Vetock & Ted Williams.

and finally, last but by no means least, thank you to all the customers and staff of Games Workshop whose enthusiasm and passion for Warhammer 40,000 over the years has been a constant source of inspiration and without who none of this would have been possible.

PRODUCED BY GAMES WORKSHOP

Citadel & the Citadel castle, Dark Angels, Deathwing, 'Eavy Metal, Eldar, Games Workshop & the Games Workshop logo, Genestealer, Space Marine, Tyranid and Warhammer are trademarks of Games Workshop Ltd registered in the UK and elsewhere in the world.

Adepta Sororitas, Adeptus Astartes, Adeptus Mechanicus, Archon, Aspect Warrior, Assassin, Avatar, Basilisk, Biovore, Blood Angels, Blood Claws, Bloodthirster, Blue Horror, Callidus, Canoness, Carnifex, Celestian, Chaos Space Marines, Chimera, Codex, Confessor, Culexus, Daemones, Dark Eldar, Dark Reaper, Demolisher, Dire Avenger, Drachon, Dreadnought, Earth Shaker, Eversor, Exarch, Falcon, Farseer, Fire Dragon, Fire Prism, Flamers, Flesh Hound, Great Unclean One, Gretchin, Grey Hunters, Griffon, Grot, Haemonculus, Hellhound, Hive Tyrant, Hormagaunt, Immolator, Imperial Guard, Incubus, Inquisitor, Jetbike, Keeper of Secrets, Khorne, Land Raider, Land Speeder, Leman Russ, Lictor, Long Fangs, Lord of Change, Mandrake, Mekboy, Missionary, Mycotic Spore, Nob, Noise Marines, Nurgle, Nurgling, Officio Assassinorum, Ogryn, Ork, Phoenix Lord, Pink Horror, Plague Marine, Preacher, Predator, Psyker, Raider, Ratling, Ravager, Ravenwing, Razorback, Reaver, Rhino, Ripper Swarm, Rough Riders, Saim-hann, Scourge, Sentinel, Seraphim, Servitor, Shining Spear, Sister of Battle, Sister Superior, Slaanesh, Space Wolves, Spore Mine, Stormboyz, Striking Scorpion, Succubus, Swooping Hawk, Sybarite, Termagant, Terminator, Thousand Sons, Tzeentch, Vindicare, Vindicator, Vyper, War Buggy, Warlock, Warp Spider, Wartrak, War Walker, Wave Serpent, Weirdboy, Whirlwind, Wolf Guard, Wraithguard, Wraithlord, Wych and Zoanthrope are all trademarks of Games Workshop Ltd.

All artwork in all Games Workshop products and the images contained therein have been produced either in-house or as work for hire.

The copyright in the artwork and the images it depicts is the exclusive property of Games Workshop Ltd. © Copyright Games Workshop Ltd, 1998. All rights reserved.

'Scatter' dice are UK registered design no. 2017484

British Cataloguing-in-Publication Data. A catalogue record for this book is available from the British Library.

UK
GAMES WORKSHOP LTD.
WILLOW RD,
LENTON,
NOTTINGHAM
NG7 2WS

US
GAMES WORKSHOP INC.
6721 BAYMEADOW DRIVE,
GLEN BURNIE,
MARYLAND,
21060 6401

AUSTRALIA
GAMES WORKSHOP,
23 LIVERPOOL ST,
INGLEBURN,
NSW 2565

CANADA
GAMES WORKSHOP,
1645 BONHILL RD,
UNITS 9-11,
MISSISSAUGA,
TORONTO L5T 1R3

HONG KONG
GAMES WORKSHOP,
2002-2006,
HORIZON PLAZA,
LEE WING ST,
AP LEI CHAU

Games Workshop World Wide Web site: <http://www.games-workshop.com>

PRODUCT CODE: 60 01 01 99 001

PART NUMBER: 60 31 01 99 001

ISBN: 1-869893-19-0



Welcome to Warhammer 40,000, the game of tabletop battles between armies of futuristic warriors, fighting machines and hordes of implacable aliens set in the far distant future.

As veteran gamers will know, this latest version of the Warhammer 40,000 game is the third to bear the title. It incorporates numerous improvements and revisions which have been suggested by players or developed in response to comments from all over the world. Overall our aim has been to produce a fast paced game that rewards good strategy, common sense and courage! The result is a set of rules that enables you to fight games between as few or as many models as you wish, from skirmishes involving a handful of determined warriors to truly vast armies with swarms of tanks and sweeping formations of troops.

If you already own huge Warhammer 40,000 armies then be reassured that you can use your existing troops with the minimum of reorganisation. Although the game is, in some ways, very different from the previous edition, demanding a different style of play and often favouring one kind of troop over another, the game is still Warhammer 40,000. Space Marines are not one jot super-human, Orks are no less brutal or ugly, and Eldar remain as sinister and elusive as ever.

I for one am looking forward to seeing the many new and bizarre developments that the Games Workshop writers, artists and model makers have lined up for the future. In the meantime, I hope that you derive as much enjoyment from reading and playing the new Warhammer 40,000 as I have from working on it.

Best Wishes

Rick P

Rick Priestley

Classified

THE ETERNITY GATE

For fourteen years I had trodden the Pilgrim's Trail. My Most Honourable Discharge for acts of extreme valour during the Gehenna Scouring was the greatest reward I could receive as a loyal citizen and servant of the Most Revered Emperor. From the multi-spired splendours of Ophelia, to the marble sepulchres of Chiros, I had witnessed the many glorious edifices of the Ecclesiarchy. And so it was that I, a humble but pious retired officer, was able to stand upon the sacred ground of Terra itself and marvel at the wondrous and magnificent Imperial Palace.

As I entered the narthex I was struck by the sheer grandeur of our worshipful buildings. Not even the Temple of Thor on Dimmamar had prepared me for the spectacle of the mile-long aisle stretching from me towards the distance-shrouded portal into the Sanctum Imperialis. The air was filled with incense, a heavy aromatic fog that was uplifting to breathe. The vaulted roof arched half a mile over my head, its recesses lost in dark shadows, supported by pillars that looked as if they could support the whole weight of Terra, such was their girth. All was constructed from the finest marble, alabaster and lunarite, and overlaid with countless precious gems, filigrees and decorations wrought from gold, silver, electrum and other rare metals from distant worlds whose names I do not know. Unnumbered gargoyles stared down at the pilgrims, each leering face more grotesque than the last. Scenes of great battles, mighty heroes and lordly saints adorned the walls. No greater celebration to the artifice of Man exists. There can be found no surer testament to Mankind's right to rule the galaxy, under the ever present gaze of the magnificent Immortal Emperor.

As I walked up the thousand steps towards the Eternity Gate, along with a multitude of other servants of the Emperor, I marvelled at the scores of banners. I am told that the oldest date from the very founding of our great Empire, carried in battles by exalted heroes whose names have become legend: Hieronymus Scathe, Count Dire, Captain Virgil, Agamar Strick, Lord Commander Macharius, Commissar Arden, Stugen Deathwalker, Colonel Gravitz and many others. To know that my labours for the Imperial Cause have been founded upon the mighty endeavours of these individuals was a stirring thought, causing my chest to swell with pride; truly to serve the Emperor is the most holy of deeds.

The Journals of Lieutenant Commander Stürn.

Chapter XVII



THE IMPERIAL PALACE

Manyfold are the labours of those who serve the Emperor on Mighty Terra itself, most exalted of a million worlds. Let us now remind ourselves of their Holy Tasks; that which gives them their reward in this life.

Give due thought to those ancient holders of Dark Mystery, the Adeptus Mechanicus. Through the magnificent artifices of their Machine God, the Magi of Mars maintain the Golden Throne which sustains the Imperius Incarnate; that breathes life into the Immortal Emperor of the Galaxy. Through their endeavours, the Protector of Mankind is freed from physical concern; liberated to spread his Mind and Word across his subjects, unfettered by any mortal barrier.

Give thanks to those most courageous and loyal of guardians, the Adeptus Custodes, who stand constant vigil over the Emperor's Palace. A veritable Legion of warriors ready to lay down their lives without doubt, for the beloved Ward of Mankind. None pass through the Imperial Palace without their knowledge; steeped are they in the arcane secrets of that labyrinthine edifice. Ten thousand blades await the call to arms; to defend against any threat, from without or from within.

Give praise to the wise Ecclesiarch of the Ministorum, and the Cardinals and Deacons who serve under him. Raise your voice in prayer and hymnal, knowing that these pious men raise their voice alongside yours in everlasting worship of the Emperor of Terra. Heed well the fables and parables that the Preachers and Confessors tell, and look to their great deeds and sacrifices to inspire your own devotion.

And let us not forget that great unnumbered mass who are the scribes and clerks, the auditors and chroniclers, the compilers and corroborators who serve in the Administratum. Through their labours, the Imperial Decree is spread to a thousand times a thousand worlds. The desires of the Most Holy, as voiced by the Noble Offices of the High Lords, are recorded and transmitted to the waiting masses. Through these humble minions come momentous tidings that tell of dire threats and great victories, craven criminals and magnificent heroes. Do not look down upon the common worker, for each finds his place as ordained by the Emperor, and serves to his best ability.



THE THRONE ROOM

Who can say what lies at the heart of the Emperor's inner sanctum? What terrible devices are there which keep our Lord alive, if life it truly is? What dark ministrations are daily vested on his shattered husk? What sickly liquids are pumped through his veins? Only the Eternal Guard of the Custodes see and they are sworn to silence. Mere mortals such as us can only guess and wonder at these and other things. But we know we must have faith for without the Emperor we are nothing.



Adore the Immortal Emperor

For He is our Protector.

Admire the Immortal Emperor

For His Sacrifice to Mankind.

Exalt the Immortal Emperor

For His Strict Guidance.

Revere the Immortal Emperor

For His Undying Guard.

Venerate the Immortal Emperor

For His Holy Wisdom.

Honour the Immortal Emperor

For His Eternal Strength.

Glorify the Immortal Emperor

For his All-seeing Vision.

Praise the Immortal Emperor

For his Enduring Rule.

Hail the Immortal Emperor

For He is the Lord and Master.

Worship the Immortal Emperor

For without Him we are Nothing.



CONTENTS

INTRODUCTION	15	YOUR TABLETOP BATTLEFIELD	28
A TYPICAL SPACE MARINE ARMY	19	THE BATTLEFIELD	28
FIGHTING A WARGAME	21	MODEL TERRAIN	29
COLLECTING AN ARMY	24		
CHOOSING AN ARMY	24		
WARHAMMER 40,000 CODEX BOOKS	24		
COLLECTING TROOPS	25		
PAINTING YOUR MODELS	26		
GETTING READY TO PAINT	26		
PAINTING	27		



WARGAME TABLE	30
SETTING UP THE BATTLE	32
THE ARMIES	32
DEPLOYMENT	32

THE RULES BOOK

RULES BOOK INTRODUCTION	36	ASSAULT	62
WHAT YOU NEED	36	1. MOVING INTO AN ASSAULT	62
DICE ROLLS	37	2. FIGHTING A CLOSE COMBAT	63
CHARACTERISTICS	38	To Hit Chart	64
UNITS	40	Damage Chart	65
THE TURN	41	3. DETERMINE ASSAULT RESULTS	67
THE TURN SEQUENCE	41	4. LOSER CHECKS MORALE	67
THE MOVEMENT PHASE	42	5. WINNERS ADVANCING & CONSOLIDATING	68
MOVING UNITS	42	MORALE	70
TERRAIN	43	TAKING MORALE CHECKS	70
		FALL BACK!	71
		REGROUPING	73
		CHARACTERS	74
		VEHICLES	77
THE SHOOTING PHASE	45	War Machines of the 41st Millennium	78
1. CHOOSE A TARGET	45	VEHICLE MOVEMENT	80
2. CHECK RANGE	47	VEHICLE SHOOTING	82
3. ROLL TO HIT	47	ORDNANCE	83
4. ROLL TO WOUND	48	Ordnance Table	83
Damage Chart	48	SHOOTING AT VEHICLES	85
5. REMOVE CASUALTIES	49	Armour Values Table	86
Armour of the 41st Millennium	50	Glancing Hit	87
CREATURES WITH MORE THAN 1 WOUND	53	Penetrating Hit	87
		Ordnance Hit	87
		VEHICLES IN AN ASSAULT	89
WEAPONS	56	JUMP PACK TROOPS	92
TYPE	56	CAVALRY	93
Weapons Table	59	BIKES	94
Weapons of the 41st Millennium	60		



THE AGE OF THE IMPERIUM

THE IMPERIUM OF MAN	98	THE INQUISITION	109
WARP SPACE	99	THE SPACE MARINES	110
THE ASTRONOMICAN	100	THE GOD-EMPEROR	112
HAZARDS OF THE WARP	100	THE DOMINION OF MAN	113
THE IMPERIUM	104	WORLDS OF THE IMPERIUM	114
THE EMPEROR	105	A GALAXY OF DAMNATION	116
THE IMPERIUM OF MAN	106	THE ENEMY WITHIN	118
ASTROPATHS	108		

THE BATTLES BOOK

BATTLES BOOK INTRODUCTION	122	RAIDS	148
THE BATTLEFIELD	123	1: SABOTAGE MISSION	149
CHOOSING A SCENARIO AND MISSION	129	2: AMBUSH MISSION	150
CHOOSING FORCES	130	3: STRONGPOINT ATTACK MISSION	151
SCENARIO SPECIAL RULES	132	BREAKTHROUGH	152
STANDARD MISSIONS	138	1: REARGUARD MISSION	153
1: CLEANSE MISSION	139	2: BREAKOUT MISSION	154
2: NIGHT FIGHT MISSION	140	3: BLITZ MISSION	155
3: PATROL MISSION	141	DESIGNING YOUR OWN MISSIONS	156
4: RECON MISSION	142	FIGHTING A WARHAMMER 40,000 CAMPAIGN	157
5: RESCUE MISSION	143	CAMPAIGNS & EXPERIENCE	159
BATTLES	144	UNIT ROSTER CARDS	159
1: TAKE AND HOLD MISSION	145	EARNING EXPERIENCE POINTS	160
2: MEAT GRINDER MISSION	146	EFFECTS OF EXPERIENCE POINTS	161
3: BUNKER ASSAULT MISSION	147	POINTS COST	161
		CHANGING A UNIT	162
		Battle Honours Table	163

THE ARMY LISTS

FORCE ORGANISATION CHARTS	166		
CHOOSING AN ARMY	167	DARK ELДАР	181
CODEx BOOKS	167	THE DARK ELДАР ARMY	182
THE SPACE MARINES	168	HQ	183
THE SPACE MARINE ARMY	168	ELITES	184
HQ	170	TROOPS	185
ELITES	173	FAST ATTACK	186
TROOPS	174	HEAVY SUPPORT	187
FAST ATTACK	176		
HEAVY SUPPORT	177		
SPACE MARINE APPENDIX	180		

THE TYRANID HIVE FLEETS	188
THE TYRANID ARMY	188
HQ.	189
ELITES	190
TROOPS	191
FAST ATTACK	192
HEAVY SUPPORT	193
TYRANID APPENDIX	194

ELDAR	195
THE ELDAR CRAFTWORLD ARMY	195
HQ.	197
ELITES	198
TROOPS	200
FAST ATTACK	203
HEAVY SUPPORT	204
ELDAR APPENDIX	207

PAINTED MINIATURES	208
IMPERIAL GUARD	209
SPACE MARINES	212
SISTERS OF BATTLE	216
TYRANIDS	217
ELDAR	218
ORKS	220
CHAOS	222
DARK ELDAR	224

CHAOS SPACE MARINES	225
THE CHAOS ARMY	225
HQ.	227
ELITES	229
TROOPS	232
FAST ATTACK	233
HEAVY SUPPORT	234

THE IMPERIAL GUARD	236
THE IMPERIAL GUARD ARMY	236
HQ.	238
ELITES	239
TROOPS	240
FAST ATTACK	242
HEAVY SUPPORT	243
IMPERIAL GUARD APPENDIX	245

THE ORKS	246
THE ORK ARMY	246
HQ.	248
ELITES	249
TROOPS	250
FAST ATTACK	252
HEAVY SUPPORT	253
ORKS APPENDIX	254



SISTERS OF BATTLE	255
THE SISTERS OF BATTLE ARMY	255
HQ.	256
ELITES	257
TROOPS	257
FAST ATTACK	258
HEAVY SUPPORT	259

HEROES OF THE IMPERIUM	260
HEROES OF THE IMPERIUM ARMY	260
HQ.	261
ELITES	263

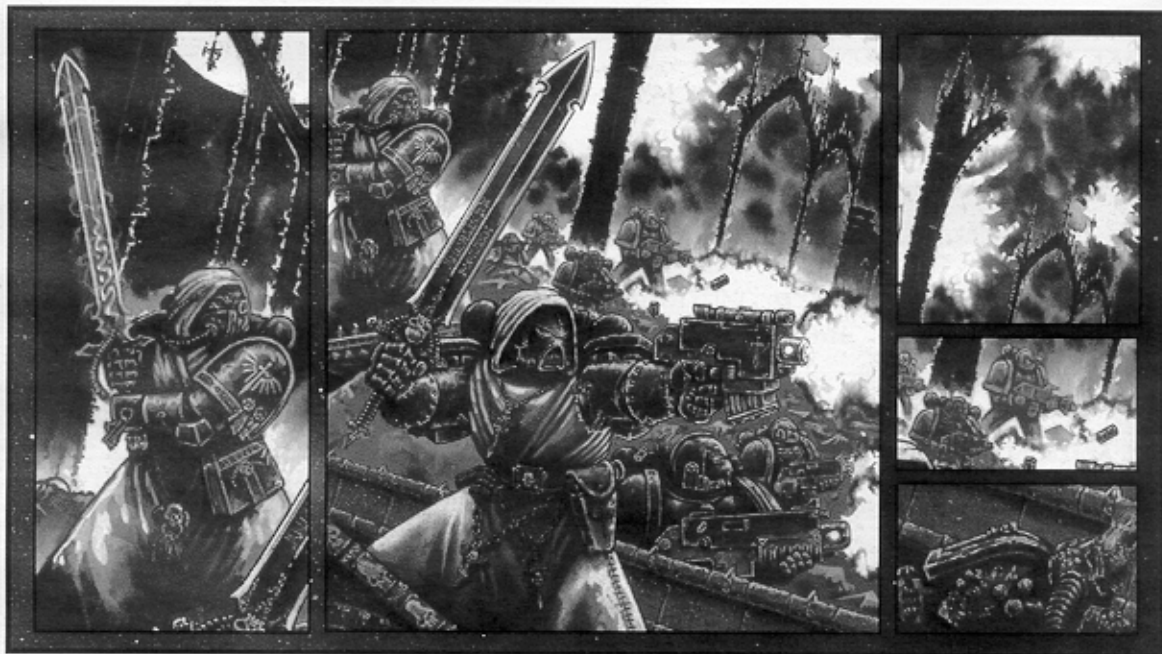

INTRODUCTION

Science fiction is more popular today than it has ever been – films, television programmes and books are filled with visions of tomorrow ranging from star-spanning Utopian societies to apocalyptic worlds in flames where even basic survival is a nasty, brutal and bloody business.

Unfortunately the nature of stories means that you can look but not touch, observe but not participate. Warhammer 40,000 changes all that! Warhammer 40,000 is a wargame that lets you command your own power armoured Space Marines in the service of the Emperor or lead your alien warriors forth to ravage and despoil your enemies.

This book has been written to explain how to go about creating exciting battles and campaigns in the Warhammer 40,000 setting. Millennia in the future when the galaxy is riven by warfare and bloodshed, humankind must battle for its very survival. You choose your own forces and create battlefields to fight over within the framework of rules presented in this volume. This book is divided into four sections containing rules, background information, battles to fight and army lists.

• **The Rules Book** gives game rules for staging your own battles using miniatures and dice.

Movement, shooting, weaponry, close combat, morale, characters and vehicles are all covered, with extra rules for cavalry, bikes and jump pack troops.



Two armies deployed for a game

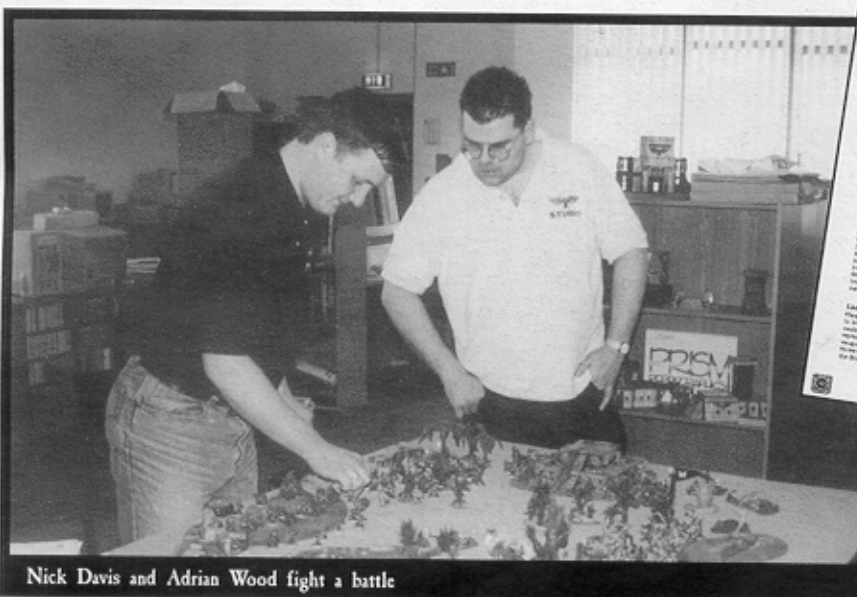

Nick Davis and Adrian Wood fight a battle

• **The Age of the Imperium** describes the dark gothic background of the 41st millennium, and the hostile alien races at war with the Imperium of man. It also details some of the worlds and labyrinthine organisations of the galaxy-spanning human Imperium.

• **The Battles Book** provides suggestions and advice about setting up a tabletop battlefield, scenarios and missions to fight, and some hints on inventing your own missions. Campaign rules are provided for troops and vehicle crews gaining experience, with notes on how to run a series of battles as a campaign.

• **The Armies Book** contains army lists that detail the organisation and equipment of the warring forces of the 41st millennium so that you can choose your troops and build your own armies.

There is also a final **Appendix** section which includes designers' notes, various treatises and reports pertaining to the Warhammer 40,000 background, a quick start section for new gamers, ready reference sheets for the rules, weapon summary sheets, weapon effect templates and army rosters.

The first part of this book is given over to discussing the nature of wargames, what choosing and collecting your own army actually involves along with a description of

a game. We've also described how to go about creating a tabletop battlefield and painting miniatures. If you've never played a wargame before you'll find it useful to read through this section before you delve into the rest of book.



Watched by Andy Chambers, Gordon Davidson and Paul Robins battle across a ruined cityscape



Imperial Guard Valhallan Infantry Squad



Chaos Space Marine



Ork Slugga Boy



Ultramarines Space Marine



Dark Eldar

There are many different armies in the Warhammer 40,000 universe. This page shows a small selection of the models available from the vast range of metal and plastic miniatures you can collect.



Genestealer



Sister of Battle



Eldar Guardian



Gretchin

Eldar Falcon
Grav Tank

A wargame is a battle between model armies of mighty warriors. The battle is fought by two players each controlling a painted miniature army complete with squads of troops, lumbering tanks and artillery!

A wargame in full swing, Imperial Guard and Orks battle it out.

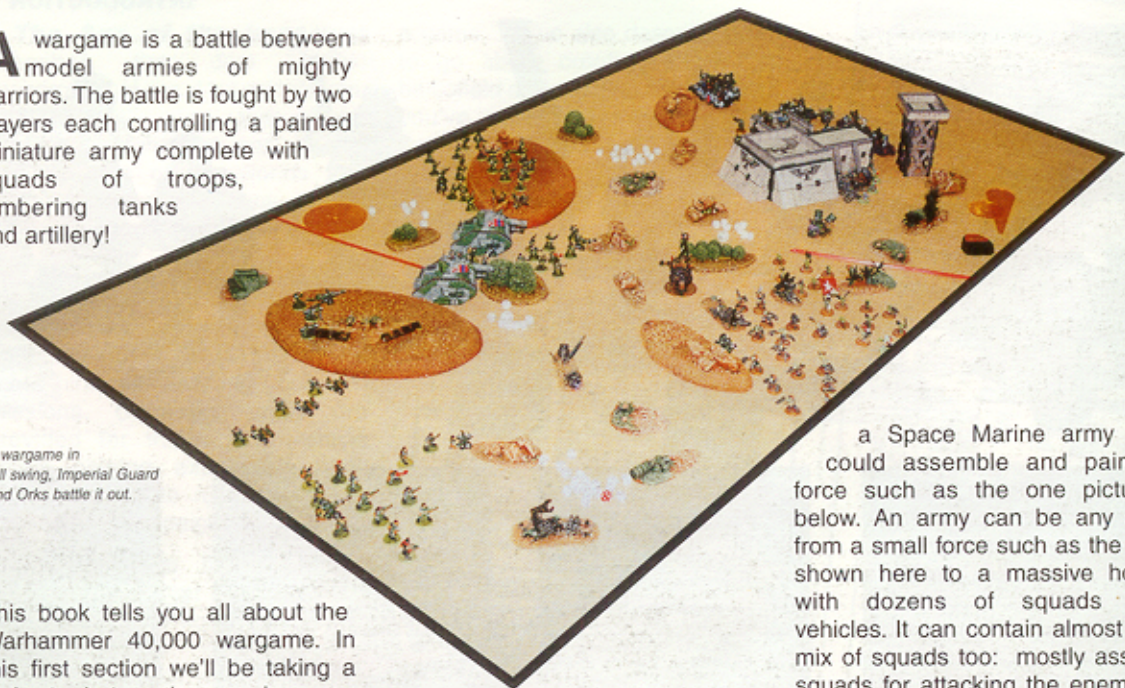

This book tells you all about the Warhammer 40,000 wargame. In this first section we'll be taking a look at what armies are, how you collect them and how to paint them. We'll also examine how to create a tabletop battlefield to fight across and how to set up a battle between the opposing forces. Later on we'll explain all this in much greater detail but it's useful to give an overview right at the start.

First and foremost, you can't fight a battle without troops, which in our case are represented by models. Model armies, just like real armies, contain different kinds of troops and vehicles under the command of an officer. Some of the armies you can collect are human, such as the soldiers of the Imperial Guard or the zealous Space Marines of the Adeptus Astartes. Other armies consist of alien creatures such as the ancient race of the Eldar, the barbaric green-skinned Orks, or the monstrous entities of the Tyranid hive fleets.

When you're starting to collect an army you will probably want to use all of it at once, so the best way to begin is with a few squads of troops and some vehicles which can fight against many different kinds of enemy. Later on, when your collection gets bigger, you can add more of the special troop types which are useful against certain enemies but perhaps not so good against others.

The bigger your collection the more choice you'll have, and you'll be able to fight bigger battles too!

A SPACE MARINE ARMY

Space Marines are genetically enhanced super-warriors dedicated to the defence of humanity. To start

a Space Marine army you could assemble and paint a force such as the one pictured below. An army can be any size from a small force such as the one shown here to a massive horde with dozens of squads and vehicles. It can contain almost any mix of squads too: mostly assault squads for attacking the enemy at close range, or heavy weapons squads for blasting the enemy apart from a distance. It might have lots of vehicles or none at all – it's up to each player to build up his collection to make the best army possible!





A TYPICAL SPACE MARINE ARMY

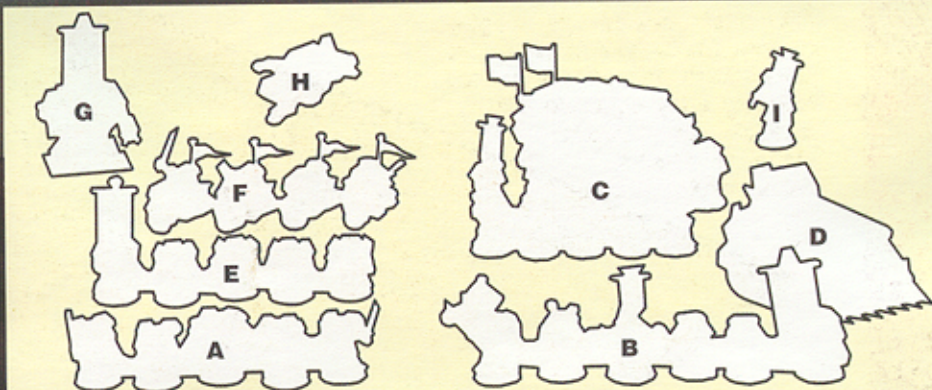

- A Assault Squad** – equipped with close quarter weapons such as pistols and chainswords. Their jump packs enable them to quickly engage the enemy.
- B Command Squad** – normally an army is led by a commander, who represents the player in person on the battlefield! They can be accompanied by a bodyguard which includes experienced veterans and specialists such as Apothecaries and Techmarines.
- C Tactical Squad with Rhino Transporter** – Tactical squads are highly flexible troops that make up the majority of squads in most Space Marine armies. Their standard equipment of rapid-firing bolters can deal with most opponents, while additional heavy weapons can be issued to deal with any enemy vehicles or monstrous creatures. Tactical squads can be mounted in a Rhino to transport them rapidly across the battlefield.
- D Razorback** – the Razorback is a variant of the Rhino that has more firepower but can still transport troops.
- E Terminator Squad** – elite Space Marines equipped with the virtually impregnable Terminator armour and carrying the deadly storm bolter. They can teleport directly into the midst of the enemy's battlelines.
- F Bike Squadron** – fast attack bike squadrons make excellent assault troops and are very manoeuvrable. They can engage the enemy quickly to support the assault squad.
- G Dreadnought** – Dreadnoughts are huge, heavily armoured fighting machines. They can be armed with a number of heavy weapons that can destroy tanks, mow down infantry or crush enemies in assaults.
- H Land Speeder Tornado** – A fast attack vehicle that can fly and is extremely manoeuvrable. The Land Speeder Tornado mounts a heavy bolter for gunning down infantry and a multi-melta for vapourising enemy vehicles. It can inflict a lot of damage but only is lightly armoured.
- I Chaplain** – Independent and resourceful characters such as a Chaplain can lend your troops much needed support on the battlefield.





Nick Davis' Imperial Guard army and Imperial fortress

This enormous Imperial Guard army collected and painted by Nick Davis shows just what can be achieved! Nick is a veteran gamer whose Imperial Guard have fought and been victorious on many a tabletop battlefield.

Like most players, Nick has given his army a personality all of its own, (he's even modelled a fortress for them!). It isn't just any old Imperial Guard army – it's the 95th Cadia Rifles Imperial Guard regiment, nicknamed 'The Revenants', under the command of Colonel Fiess. Most players like to choose a suitable name for their commander and army. After all, how do you think your troops would feel if their commander didn't even have a name?

As you can see, the army includes different kinds of troop types – Imperial Guardsmen, Commissars, Ratling Snipers, Storm Troopers, savage Attilan Rough Riders and the brutal Ogryns. These all fight as part of the Imperial Guard. Nick has also included loads of armoured vehicles in his army such as a Hellhound flame tank and a Leman Russ battle tank squadron!

There are many specialised vehicles and elite troop types ready to recruit into whichever army you choose to collect. Most of the

special models available for the Imperial Guard are included within this army but not all in great quantity! The gaming rules that explain how to use these special pieces will be covered by a supplementary Warhammer 40,000 Codex book.

Nick's army is now so big that he rarely gets to field all of it at once, but with such a huge collection he can always choose to use the troops he thinks will fight best in different scenarios against different enemies.

When you start to collect your army you'll probably want to use all of it at once, so the best way to begin is by collecting lots of infantry units to form a core and then add a couple of vehicles. This type of force can fight well against many different kinds of enemy. After you have learned how your army fights, you can enlarge it with more specialised troop choices. This will increase your options against most enemies.

Remember that the bigger your army the more options you'll have, and, of course the bigger battles you'll be able to fight.



Nick and Adrian battle it out in a 'Cleanse' mission

FIGHTING A WARGAME

Having explained the basic principles of wargaming, what follows is a report of Warhammer 40,000 game being played. A game report uses a combination of maps, photos and writing to depict victories, defeats and the whole drama of war on a small scale, all for your entertainment! Game reports like this are a common feature in Games Workshop's monthly White Dwarf magazine. Reading game reports is a very good way to see armies in action and pick up hints and tips about tactics and choosing an army.

Our two players, Gavin Thorpe and Andy Chambers, are about to start the game. Gavin Thorpe (henceforth noted as Farseer Tyladrhas) and Andy Chambers (Space Marine Captain Cassius) are playing a small battle and have already deployed their opposing armies onto the tabletop. Exactly where the the players troops can be deployed is determined by the scenario they are playing. In this case they are attempting to cleanse the battlefield of enemy forces, so they each start in one quarter of the battlefield and will need to control as many of the other three quarters of the table as possible by the end of the game crushing opposing units as they go!

THE FIRST TURN

The players each roll a dice to see who goes first. Captain Cassius wins the first turn by rolling the highest score – a good start! The Space Marine force swings into action by sending its squad of Terminators towards the nearby hill beyond the ruins. Realising its value as a defensive position, Captain Cassius sends his Space Marine squad to occupy the ruins. Captain Cassius and his squad then take up position behind the ruins so that they can move to where the fighting is fiercest later in the battle. As they advance the heavily armed Terminators open fire on the Eldar Rangers lurking on the edge of the jungle, gunning down several despite their concealment in the cover.

The Eldar are undaunted by their enemy's guns. They begin their first



Gavin Thorpe

GAV'S ELДАР ARMY



- Farseer Tyladrhas:** *Shuriken pistol & Witchblade*
- Striking Scorpions:** *6 with chainswords & shuriken pistols*
- Guardian Defender Squad:** *5 with shuriken catapults*
- Eldar Rangers:** *8 with sniper rifles*



Falcon Grav Tank



3 Jetbikes



Vyper

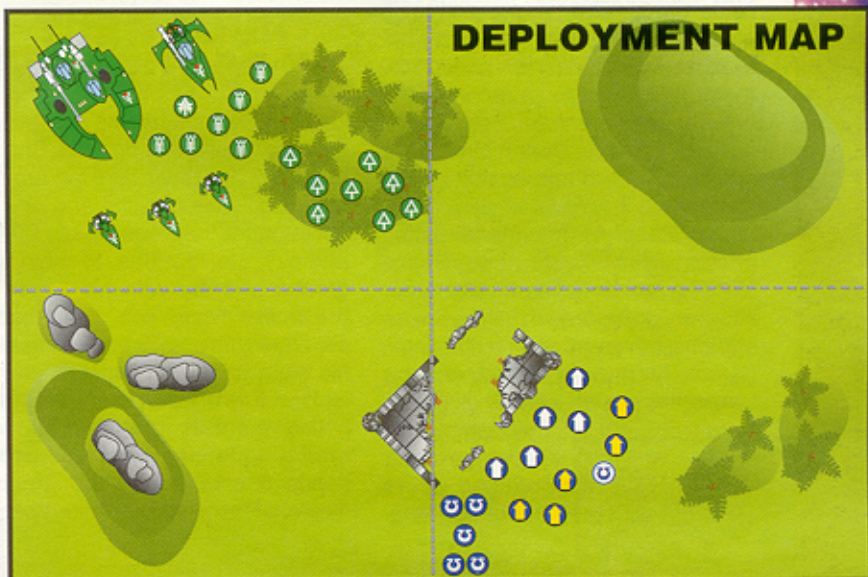

DEPLOYMENT MAP



Andy Chambers

ANDY'S SPACE MARINE ARMY



- Captain Cassius:** *Boltgun, bolt pistol & power fist*
- Terminators:** *Sergeant with power sword, 1 with an assault cannon and power fist, 3 with storm bolters and power fist*
- Space Marine Tactical squad:** *4 Space Marines with bolters and 1 with a flamer*
- Space Marine Tactical squad:** *Sergeant with power fist, 3 Space Marines with bolters and 1 with a missile launcher*



Turn 1 Map



The Space Marine Tactical squad takes cover in the ruins as the jetbikes attack

turn by slipping around the enemy centre. The sleek jetbikes fly past the Terminators, while the heavier Vyper and Falcon grav vehicles circle around the jungle, skimming along just above the ground. Sinister Aspect Warriors move into the jungle to support the beleaguered Rangers against the hulking Terminators that are advancing on their position. The Falcon and the Vyper let fly with the heavy weapons mounted in their turrets, targetting the Space Marines amidst the ruins. Shot after shot is deflected by the Space Marines' power armour, but a single Space Marine is felled by the awesome power of the Falcon's lascannon, his power armour reduced to bubbling slag.

The Rangers shoot at the Terminators, but even their finely-crafted sniper rifles can find no chinks in the Terminator's heavy armour.

ON TO TURN TWO

Captain Cassius begins his second turn unsure what to do next. Should he attack the Eldar flanking around him or hold his position and rely on his superior firepower to see off his enemy? He decides to hold his ground and fire with his forces in the ruins while the Terminators continue their attack. Fortunately his stalwart Space Marines do not let him down, the squad in the ruins hitting the Eldar Falcon with an armour piercing missile which sends it crashing to the ground! Captain Cassius' own squad target

the jetbikes and knock one out of the air. For their part the Terminators hammer the Eldar Rangers again, and this time the Rangers decide to fall back from the Terminator's line of fire. Destroying the Eldar Falcon has given the Space Marines a big advantage but now they must survive the Eldar response.

Farseer Tyladrhas is still confident at the start of his second turn, for his forces are now in position to counter-attack and wreak havoc upon the Space Marines. The Guardians also survived the wreck of the Falcon open fire, along with the jetbikes and the Vyper. Under a ferocious hail of fire the Space Marines lose three more warriors from the squad in the ruins, leaving only the Space Marine with the missile launcher alive! The Striking Scorpion Aspect Warriors in the jungle charge out to fight the Terminators in hand-to-hand combat and cleave down one of them before the Terminators strike back and crush two of the Scorpions. The Scorpions fall back to the safety of the jungle, easily outpacing the Terminators as they move away. Farseer Tyladrhas' turn is over and he can only await the Space Marine's onslaught.



Turn 2 Map



Striking Scorpions charge the Terminators

TURN THREE

Sensing victory, Captain Cassius orders his Space Marines to attack the remaining Guardians while the Terminators advance as rapidly as they can. With Captain Cassius

leading them the Space Marines charge with a mighty roar. The Eldar Guardians fight back fiercely but they are no match for the mighty Space Marines. The Guardians attempt to fall back but the Space Marines mercilessly press forward, pursuing the enemy and cutting them down until not one Guardian is left alive!

The Terminators also fire on the retreating Aspect Warriors and punch through the armour of one unlucky Scorpion. The turn is a great set back for the Eldar who have lost all the troops on their right flank, leaving only the jetbikes and the Vyper to hold back the Space Marines. But Captain Cassius' turn is over and he knows Farseer Tyladrhas is not finished yet!

Things look pretty bad for the Eldar army, but Farseer Tyladrhas is too experienced to give up just yet. The Striking Scorpions and the Rangers successfully regroup behind the jungle and move to keep the jungle between them and the deadly Terminators. Meanwhile the Vyper and the jetbikes buzz past like angry hornets, targeting the last



Space Marine Captain Cassius leads the assault on the Eldar Guardians

Space Marine in the ruins and eliminating him in a hail of fire.

TURN FOUR THE FINAL TURN

The Space Marines have lost more than a third of their number but the Eldar are almost spent. Captain Cassius considers carefully how to complete driving the enemy from the battle.

He orders the Terminators to advance into the edge of the jungle, from where they open fire on the Vyper near the ruins. Their shots punch through the vehicle's armour, making it spiral out of

control and crash. Captain Cassius and his squad target the jetbikes and succeed in knocking down one of them in a hail of bolter fire.

With only the Scorpions and the Rangers left to command, Farseer Tyladrhas can only attempt one thing to stave off defeat – destroy the Terminators at all costs. Led by the Farseer himself, both units plunge into the jungle to attack the seemingly unstoppable Terminators. A vicious hand-to-hand combat ensues with Farseer Tyladrhas cutting down one Terminator and the Scorpions felling another, however, the lightly-armed Rangers make no impression on the massive Terminators at all and can only wait to see what damage they will suffer in return.

The vengeance visited by the Terminators for the loss of their brother marines is bloody. The Scorpions and the Rangers suffer one casualty each, but worst of all Farseer Tyladrhas is himself felled by a mighty blow from a Terminator's power fist. Although the Eldar are not driven back their hopes of defeating the Terminators have come to nothing.

As the battle ends the Space Marines control just a single quarter of the table, but the Eldar are too weak to contest any others. The Space Marines too are badly mauled but with his opposite number dead Captain Cassius can offer a prayer of thanks for his triumph! It is victory... just... but a victory none the less.



Farseer Tyladrhas leads the final assault against the Terminators

COLLECTING AN ARMY

By purchasing and painting one unit of troops at a time, you'll soon see your army grow into an impressive force.

CHOOSING AN ARMY

Before you start collecting an army, you'll have to decide which one you want. Different races have different troop types, fighting skills and technological assets. The Imperial Guard, the human troops of the Imperium, make great use of tanks and artillery in their armies, while Ork warbands fight in huge mobs of ferocious warriors supported by insane bikers and swarms of crude vehicles.

Later on in this book you'll find army lists which detail what kinds of troops, weapons and tanks different armies can use. The army lists are a vital part of the book because they tell you how many and what sort of troops you can have in an army. While you can always make

choices about how you compose your force, certain combinations or numbers of troops may be restricted. This is to preserve the character of the different armies, and to ensure a balanced selection. An army that consisted entirely of tanks or artillery wouldn't give you or your opponent much choice of tactics.

Within the selections permitted, the army lists are very flexible. It's unlikely that any two players would ever pick precisely the same combination of troops.

We have also included lots of photographs of painted models in this book to inspire you, indeed to many people the look of an army is just as important as its performance on the battlefield. If you live near a Games Workshop store go down and have a look at the painted models they have there. All Games Workshop store staff are keen gamers themselves, so they'll be happy to give you advice.

WARHAMMER 40,000 CODEX BOOKS

Once you've chosen your army, you'll want to know more about it, how it fights, and what special models it can include. You'll find all this and more besides in the Warhammer 40,000 Codex book for your army. Each Codex tells you more about the race, details uniforms and paint schemes, describes the different weapons and troop types they use, any special rules they might have, and contains a full army list.



Just a small selection from the vast range of Citadel miniatures available for Warhammer 40,000

COLLECTING TROOPS

Most players start by buying a few models and painting them without worrying too much about points values or what they are. This gives you a flavour of the army, and by adding sufficient models to make up squads, enough to play a modest game. By adding more squads, as well as vehicles, heroes and other special models your army will soon grow bigger. How big your collection grows is up to you!

Ultimately it is better to have more troops than you need for a battle as this gives you the opportunity to 'tailor' your force to suit your opponent. Some troops are more effective against others, for example Imperial Guard fire support squads are great at cutting down enemies who attack in large units such as Orks and Tyranids.



Imperial Guard
Leman Russ battle tank



Eldar Guardians



A mighty Chaos Lord



Chaos Space Marine squad



A vicious mob of Orks

PAINTING YOUR MODELS

Although you don't have to play Warhammer 40,000 with painted models, there's nothing to match the sight of two painted armies facing each other on the tabletop. Some people paint their models quite simply, so they can start gaming straight away, while for others painting miniatures becomes a satisfying hobby in itself. Most gamers, though, fall between these two extremes, and paint models to a standard they feel comfortable with, but which allows them to finish their armies relatively quick

GETTING READY TO PAINT

You will need to set up a painting area before you start. A table or desk next to a window is best, so

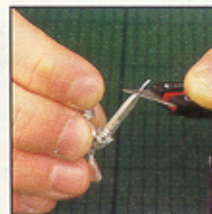

you can paint in natural daylight. Spread a thick layer of newspaper on the table to protect the surface in case you have an accidental spillage of paint, water or glue.

As well as paints and brushes, you'll need to find a few more bits and pieces of equipment – a jar to put the water in, some kitchen roll to wipe your brushes on, and an old plate or plastic palette to mix paint on.

PAINTING AN ARMY, NOT SINGLE MODELS!

Painting Citadel miniatures is mostly about painting multiples of models. Eventually you may wish to fight battles with a hundred odd models per side in which case there is no point spending hours on each miniature. A couple of hours on a squad of ten is more like it, enabling you to build up a sizeable force quickly. Simply paint each colour on



▲ You don't need much equipment to start painting – a couple of brushes, some paint, glue and a modelling knife will do.

all five or ten miniatures before moving onto the next colour or area. By the time you've finished one colour the first model will be dry and ready for the next stage.

PREPARATION

Before you start painting a model, you need to do a little preparation. First check the model for 'flash', the fine mould lines that are left over from the casting process, and trim them off carefully with the modelling knife. Next, glue the model into its slottabase.



▲ This portable home made painting tray is ideal

PAINTING A BLACK TEMPLAR SPACE MARINE



1 After cleaning up your Space Marine miniature, undercoat it with black Citadel spray paint. Alternatively you can brush on black.



2 Paint the chest eagle and the shoulder pads white. Don't worry about making mistakes. When the white is dry, simply tidy up any accidental brush strokes with black.



3 Paint the boltgun, the pipes on the helmet and the exhausts on the backpack in metal. It's now time to start on the base. You can simply paint the base green, or for an extra touch glue sand to the base before you paint it green. Your Space Marine is now ready for battle.



4 To add a finishing touch to your model you could paint the eyes and the gem of the chest eagle in red. Then apply transfers to the shoulder pads. If you feel really confident with a brush, you could also paint the edges of the armour with light grey to exaggerate the detail.

Some models (like the ones shown here) benefit from a undercoat of black paint instead of the more usual white. Heavily armoured models, or models that are mostly painted in dark colours, all work well with a black undercoat. Note that you may need to paint two coats of the same colour to get a good finish.

UNDERCOATING

Just one more thing to do now – paint on an undercoat. This is a thin layer of white or black paint that seals the metal or plastic of the model, and gives you a better surface to paint on. You can skip the undercoat if you like, but you'll find it much easier to paint models if you undercoat them first. A good way to undercoat models is to spray them with paint designed specifically for this purpose (such as Citadel Colour Black and White Undercoat sprays).



▲ Spray your models in a well ventilated area, preferably outdoors. If you place your models on an upturned box you can rotate them and spray the other side without having to touch them.

It's best not to use the paint straight from the pot, as it can be too thick. Take some of the colour you want to use from the pot with a brush and put it onto your palette. You can then thin it down with a little water, or even mix in another paint to get a new colour. Remember to wash your brush each time you change colours, or you could end up with a rather muddy set of paints!

BASING YOUR MODELS

As a finishing touch to your models, it's a good idea to flock their bases. This not only helps to present them better, but also enables you to keep their bases the same colour as the battlefield you use for your games. Flocking bases is very simple:

① Fill any gaps in the base with blue tac, tape or similar material. Paint the base green.

② When dry paint PVA glue on the top of the base.

③ Before the glue dries, dip the base into some flock, lift it out, then shake off any excess. When dry the model is ready to join its squad.



▲ The Warhammer 40,000 paint set contains nine basic colours: Blood Red, Skull White, Chaos black, Snakebite leather, Bad Moon yellow, Dark Angels green, Ultramarines blue, Bronzed flesh and Boltgun metal. The box also contains two paint brushes and a unit of five Space Marines.

PAINTING

Now you are ready to paint! Just paint each area of your model in an appropriate colour. If you were painting an Ork for example, a good start would be to paint all his skin green. If you'd chosen a human, you would paint his hands and face in a flesh-coloured paint.

Paint each area of your model, as neatly as you can. If you make a mistake, you can always paint over it. Wait for each area to dry before painting a fresh colour next to it, or the two colours may run together.

PAINTING A DARK ELДАР



① After cleaning up your Dark Eldar miniature, undercoat it with black Citadel spray. Alternatively you can brush on black.

② Paint the large flat areas of your model, like the shoulder pads and helmet, purple. Also pick out any armour plates and paint those purple as well. You can use black paint to tidy any areas of black which you may have accidentally covered in purple.

③ Paint the helmet plume and the gun metal. It's now time to start on the base. You can simply paint the base green, or for an extra touch, glue sand to the base before you paint it green. Your Dark Eldar is now ready for battle.

④ To add a finishing touch to your model you could paint gold on the ridges of the helmet and paint the eyes yellow. You could also paint the helmet plume with chestnut ink and paint the gun with a coat of thinned down black ink.

YOUR TABLETOP BATTLEFIELD

An elaborate or expensive set-up is not required to play a wargame. That doesn't mean that most hardened gamers don't aspire to create their own specially equipped games room! In this ideal environment the wargames table can be left permanently in place, battles can be abandoned and resumed at any time without having to be cleared away, and ranks of models can be displayed safely upon shelves.

For most people the chances of dedicating an entire room to the hobby are slim. There are simply too many demands upon most people's living space to indulge such a luxury. That doesn't mean you can't enjoy a perfectly satisfactory wargame however, although you may have to make sure your games are fought over the course of an evening or afternoon, and that model armies and terrain are safely stowed away after use.

THE BATTLEFIELD

Imagine you and your opponent wish to fight a battle. Aside from the opposing armies themselves the most obvious requirement is somewhere to play the game – a



▲ The photographs above show two types of playing surfaces that represent a desert planet. Top: A cloth battlefield on a table with books placed under the cloth to make hills. Bottom: A Sulphur Desert Battle Mat (available at Games Workshop stores) with homemade terrain such as boulders made out of stones and hills made from polystyrene.

battlefield! What is needed is a flat and sturdy surface of a reasonable size. An area about 3' by 4' will do at a pinch; obviously bigger armies require more space in which to fight.

The most readily available battlefield is the floor, and there is nothing wrong with clearing some space and crawling about on your hands and knees in pursuit of victory. A further advantage is that

should you drop a model it is unlikely to come to any harm, models plummeting from a table are not always so lucky!

Although the floor is the most readily available playing surface, there are plenty of alternatives which are almost as simple to arrange. You might be fortunate enough to have a suitable kitchen table or large desk.

BATTLEFIELD TERRAIN

◀ Plastic ruins

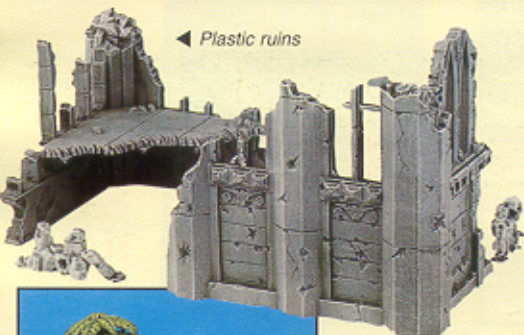

◀ Plastic jungle trees



▶ Sand covered cardboard lake.



▲ Jungle tree made with wire and paper.
◀ Alien plant made with polystyrene and cocktail sticks.



▲ Cardboard hills covered in green flock.



▼ Boulders made with real stones.



◀ Cardboard and polystyrene craters, covered in sand.



On the other hand, and with just a little more effort, it is possible to buy a sheet of stiff board which affords a very satisfactory surface and which can be placed over a bed or on top of a small table to increase its playing area. Such a board can be stored on its side against a wall, under a bed, or behind a wardrobe when not in use.



▲ Two gaming boards made from a thick sheet of polystyrene (top) and chipboard (bottom).

► Many gamers eventually make their own wargames table from a piece of chipboard or fibre board (obtainable from any DIY stores). A good sized area measures 8' x 4', although it could easily be larger or smaller depending on how much space you have available. You will need to strengthen your table by screwing some wooden battens underneath the outside edges and across the middle, to make the table more sturdy. Then all you need to do is paint the table the colour of your choice (emulsion paint works best), and your wargames table is ready for use.



Green Flock

Sand

Brown Flock

Small Pebbles



▲ Adding a layer of texture to your gaming surface will make your battlefield look all the more realistic. Flock is ideal for this and can be stuck to the board by sprinkling it over a layer of watered down PVA glue.

For an even more textured

terrain, you can try mixing sand or small pebbles into a tub of all-purpose filler and applying the mixture to the board. Once dry, you can paint the gaming surface whatever colours you like.

MODEL TERRAIN

Whatever form your battlefield takes, it will benefit from the addition of extra scenic features such as hills, trees and buildings. It is possible to buy suitable model terrain and Games Workshop manufactures a range of polystyrene hills, card self-assembly buildings and model trees especially for Warhammer 40,000. On the other hand, most players start off by improvising scenery for themselves as this is not difficult and leaves precious resources for

expanding the armies themselves. Many players find that they already have a few models that can be adopted, perhaps from a model railway layout for example.

Even if this is not the case, it is possible to represent hills, and even more complex contours, by covering your battlefield with a blanket or some such heavy cloth and positioning books or sturdy boxes underneath to form the hills. Similarly, the author has fought upon perfectly useable battlefields where painted pine cones have

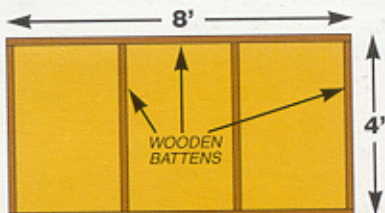

Construction plan for an 8' x 4' wargames table

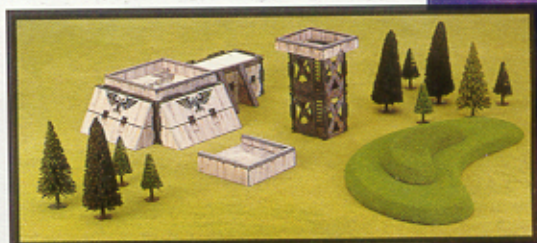

▲ This is just a small selection of the terrain available from Games Workshop stores.

been pressed into service as trees, twigs have been turned into blasted tree trunks, and pebbles from the garden have been arranged to form walls and rocky outcrops.

BATTLEFIELD TERRAIN



▲ River section made from cardboard, sand and clear-setting PVA glue.

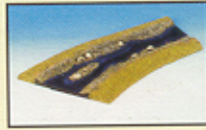

◀ Fences made with wire mesh.



▲ Shelters made from cardboard tubes.



▲ Cardboard shelters covered in textured paint.



► Industrial installations can be made using very simple shapes like cubes and cylinders. This one is made from sheets of card, cardboard tubes and drinking straws.

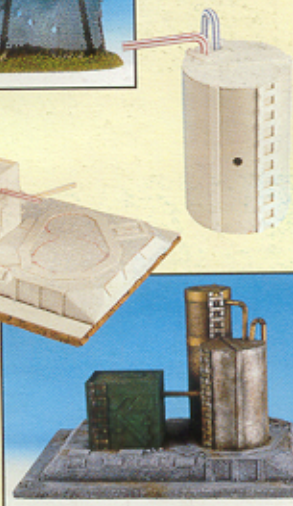

WARGAME TABLES



8' by 4' wargames table of a desert world featuring an Ork settlement.

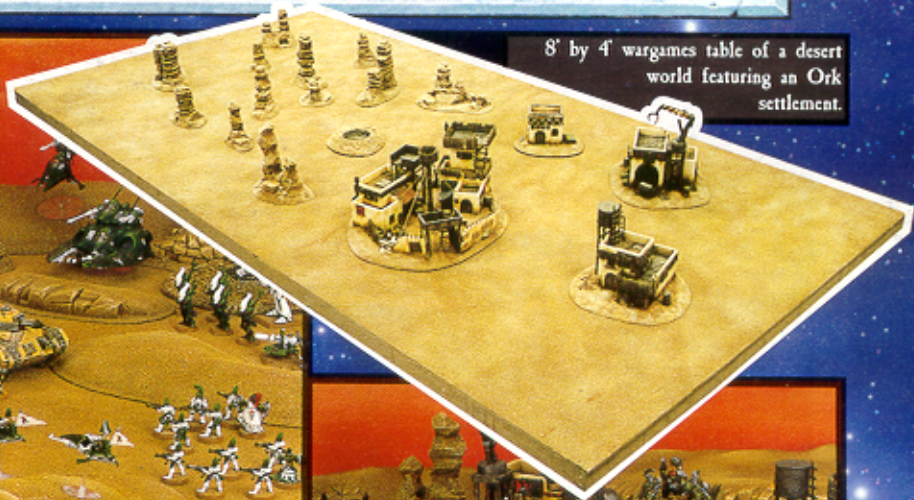

8' by 4' Ice world wargames table with snow drifts and research station.



This 4' by 4' wargames table can be used to fight battles on forge worlds or in Imperial cities.

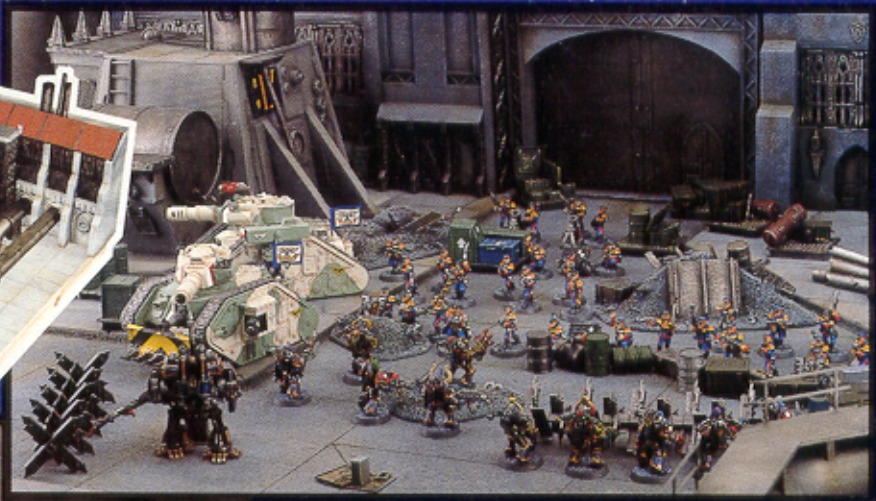
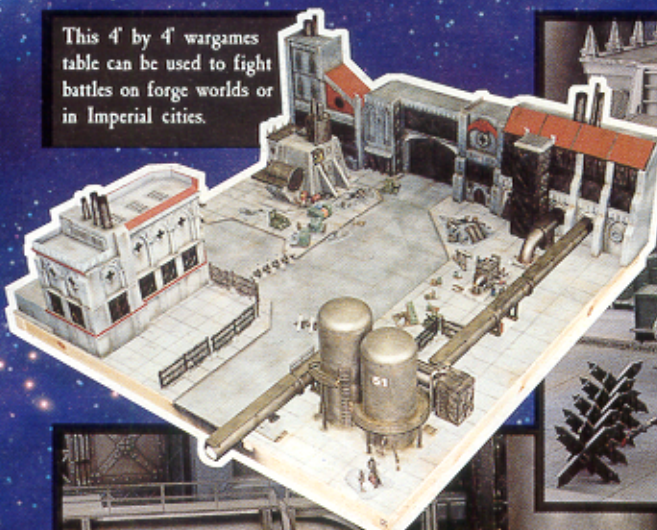

The battle-scarred terrain on this 4' by 4' wargames table is made up of two 4' by 2' boards one with an extensive trench system, the other with a crater-marked plain.



SETTING UP THE BATTLE

When it comes to setting up your battlefield you might choose to recreate a situation you've seen on film, or have read about in a book. Alternatively you could invent a plot: an Imperial convoy is ambushed, Space Marines are despatched to investigate loss of communications with an outpost, Ork pirates assail a mining settlement....and so on!

The most straightforward kind of battle is a clash between two armies, both sweeping the sector to eliminate enemy forces. We call this a Cleanse mission – a battle where two forces of roughly equal size face off against each other.

On this page you can see a map showing one way of arranging the scenery for an encounter like this. You can, of course, arrange the scenery any way you like, changing the layout every time you play. A good way to lay out the scenery is for each player to position one feature at a time, or for one player to place the scenery whilst his opponent chooses which side his army will start on. It doesn't matter how you set up your battlefield – but try to make sure the layout is reasonably balanced and doesn't favour one side.

THE ARMIES

Once the battlefield is laid out it is time to deploy the armies. It is assumed at this point that players

have armies of roughly equal size and ability, so that the battle will be a fair contest. Warhammer 40,000 army lists present players with a means of calculating the relative value of their forces, but to start with just make sure that both forces are of roughly equal size. You can always swap sides and play again later.

Let us suppose that our two generals are fielding a Space Marines army and an Eldar army. The Space Marines have some Space Marine Tactical squads plus some Space Marine bikers and a land speeder. The Eldar have several large units of lightly armoured Guardians, some Guardians mounted on jetbikes and heavily armed Vyper jetbikes.

There are fewer Space Marines than Eldar, but this doesn't matter too much because Space Marines are far better warriors than the highly advanced but lightly equipped Eldar!

DEPLOYMENT

Setting the armies up ready for battle is called *deployment*. How you arrange your forces is important because tactics are

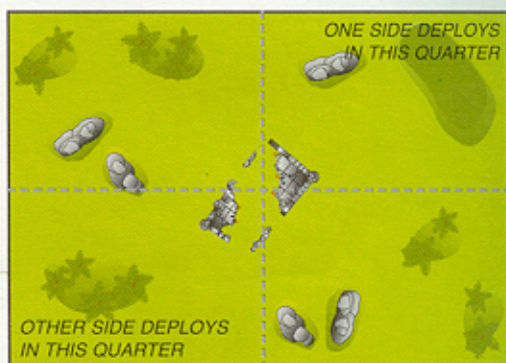

▲ Map of a Cleanse mission setup – note in a Cleanse mission the table is divided into quarters.

determined by where your troops start from, and may well decide which side wins or loses. It is important that one player does not gain an unfair advantage by watching his opponent deploy, enabling him to set up his troops in the most advantageous positions. In reality generals must make their plans and stick to them, and rarely have the opportunity to change their mind once a battle has begun.

In a 'pitched battle' the armies are deployed in opposing table quarters. Each player rolls a dice and the player who rolls the highest score places one of his units in his table quarter. Once the first player has deployed a unit his opponent deploys one of his in the opposite table quarter. To ensure that the two sides do not start too close together the opposing unit may not be deployed within 18" of the unit already in place.

The players continue taking turns position their units until all the units have been deployed. If one player has a significantly more units than his opponent it's a good idea for him to deploy first, as this will help to even things up. In any case, once one army is entirely deployed any remaining units can be positioned on the other side and the game is ready to begin!

It is easy to vary the way the armies set up, allowing some troops to deploy at the table sides, or others to begin in the centre of the battlefield. Similarly, some forces can be kept off the table altogether and introduced as 'reserves' at a later stage of the game. This kind of thing is discussed in more detail later in this book.



Tyrannids assault a Blood Angels position

RULES BOOK



Thought for the Reverent: The wise man learns from the deaths of others.

00x3, 00a Regum finis



It is the savage beast of war that drives Mankind on his course and pursues him to his destruction. It feeds upon his terror. It grows more hungry with each passing year and soon it shall consume him whole.

The Age of Battle is begun. The fires of war burn brightly from star to star. Everywhere the fortresses of Man are steeped in blood and ancient enemies appear from the darkness. Sensing weakness they gather for the kill. They know as we know that as night approaches all mortal life shall be extinguished. We know, as they cannot, that there shall be a new dawn and a new day when we will rise anew and they will be driven into the darkness forever.

The Age of Battle is Begun.



RULES INTRODUCTION

This section of Warhammer 40,000 details the rules of the game – the nuts and bolts of how different troops move and fight on the battlefield. You do not need to have learned all the rules to begin playing, in fact if you try to learn everything at once you may end up over-stretched and confused.

If you've never played a game like Warhammer 40,000 before, we recommend you read 'To Battle' at the back of this book, and work through the example combats shown there before you start reading the rules properly.

Very few games of Warhammer 40,000, especially if you are just starting out, will involve all of the rules given over the following sections. Our advice is to have a quick look through the rules once. You don't have to read every word, just get an idea of what's going on and where different rules can be found. After that, the best idea is to get stuck in and play a few games! As you come across situations you're not sure how to deal with, look up the

relevant section and read the rules as you are playing. In particular, the sections on Characteristics, The Turn, The Movement Phase, The Shooting Phase, The Assault Phase and Morale contain all the basic rules you need to play.

By starting this way you'll find that you pick up the core rules in a few games and will be able to play most of the time with just the information on the playsheet. As you introduce other elements into your games, such as heroic characters, lumbering tanks and Dreadnoughts, read through the appropriate rules and refer to them while playing.

WHAT YOU NEED

As well as the Warhammer 40,000 book, there are a few other items you will need while you are playing. For a start, you'll need two or more players, with a selection of miniatures to represent their forces and a battlefield for them to fight over. Any firm, level surface will do, such as a tabletop or an area of floor – most kitchen tables will do fine! It's a good idea to protect the

table from scratches and chips with a blanket or cloth. Some players use a special gaming board made from chipboard on top of the table to extend their playing area. To complete the battlefield you should try to obtain some terrain such as hills, fences, ruined buildings, jungle or woods. Terrain, whether you made it yourself or bought it, adds realism to your battles and gives

armies something to fight over or use as much needed cover from enemy fire. You can find out more about armies and battlefields in the Battles Book.

As well as players, armies, a battlefield and terrain there are a few other things you'll need when playing. For troop movement etc, you will need at least one measuring device marked in inches (such as a ruler or retractable tape measure). All distances in Warhammer 40,000 are in imperial measurements.

You will need some ordinary six-sided dice, and a Scatter dice will also be useful. Finally, a pen and some paper can be handy for noting down damage to vehicles, casualties on units and other details that will crop up during a game.



DICE ROLLS

There are lots of occasions in Warhammer 40,000 when you have to roll dice to see how the actions of your troops turn out – how effective their shooting is, what damage they've done to a vehicle, how far they fall back from enemy fire and so on. All of the dice rolls in Warhammer 40,000 use a standard six-sided dice (usually shortened to 'D6'). Sometimes you may have to modify the result of the dice roll. This is noted as D6 plus or minus a number, such as D6+1 or D6-2. Roll the dice and add or subtract the number to or from the score to get the final result. For example, D6+2 means roll a dice and add 2 to the score, giving a total of between 3 and 8.

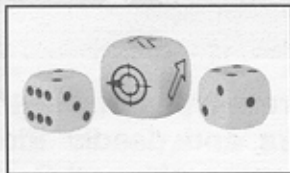

You may also be told to roll a number of dice in one go, which is written as 2D6, 3D6 and so on. Roll the indicated number of dice and add the scores together, so a 2D6 roll is two dice rolled and added together for a score of between 2-12, 3D6 adds together the scores of three dice for a total of 3-18 and so on. For example, a 2D6 roll of a 5 and a 3 are added together to score 8. Another method sometimes used is to multiply the score of a dice by a certain amount. Therefore, D6x5 means roll a D6 and multiply it by 5, giving a total between 5-30.

Sometimes a combination of these methods may be used, such as 2D6+5 giving a score of between 7 and 17, or 3D6-3 which will total 0-15.

In very rare circumstances you may be told to roll a D3. Since there's no such thing as a three-sided dice, use the following method for determining a score between 1 and 3. Roll a D6 and halve the score, rounding up. Thus 1 or 2=1, 3 or 4=2 and 5 or 6=3.

SCATTER DICE

A few weapons are fairly random in their accuracy and require you to roll a Games Workshop Scatter dice to determine where they land. This Scatter dice is marked on four sides with an arrow, and on two sides with a special 'HIT' symbol. Simply roll the Scatter dice near the target point, if an arrow is rolled this shows which direction the shot has deviated in. If a Hit symbol is rolled this generally means the shot is bang on target. Some weapons may scatter automatically, with no chance of a direct Hit, in which case you will find a small arrow on the Hit side to determine the direction.

Although a Scatter dice is the best way to determine random direction, you can achieve a similar result by using a D6. Put this book flat on the table with the arrow marked 1 on the diagram facing in the direction you want the weapon to fire. Roll a D6 and on a score of 5 or 6 the hit lands on target. If you roll 1, 2, 3 or 4 then the shot scatters, as shown. This method isn't as random as a Scatter dice but suffices in most circumstances.

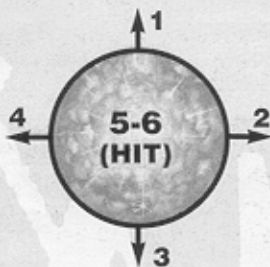

RE-ROLLS

In some situations the rules allow you a 're-roll' of the dice. This is exactly as it sounds – pick up the dice you wish to re-roll and roll them again. The second score counts with a re-roll, even if it means a worse result than the first, and no single dice can be re-rolled more than once, regardless of the source of the re-roll.



We are the Space Marines.

The champions of Humanity.

The Emperor's chosen warriors.

For every one of us that falls in battle one hundred enemies will die.

CHARACTERISTICS

In Warhammer 40,000 there are many different types of warriors ranging from the mighty Space Marines to the brutal Orks and deadly Eldar. There are other creatures as well, some small, such as the green-skinned Gretchin, and others as massive as the dreaded Tyranids. To represent these creatures in the game there are nine categories that describe the various aspects of their physical or mental make-up. These are called *characteristics*.

All characteristics are measured on a scale of 0 to 10. The higher a characteristic the better it is. The characteristics are: Weapon Skill (WS), Ballistic Skill (BS), Strength (S), Toughness (T), Wounds (W), Initiative (I), Attacks (A), Leadership (Ld) and Save (Sv).

Weapon Skill (WS)

Defines how skilled a warrior is with his weapons in hand-to-hand combat, or how determined and vicious a creature is. The higher the score the more likely the fighter will land blows on a hand-to-hand combat opponent. An ordinary human has a Weapon Skill of 3. A battle-hardened Space Marine will have a Weapon Skill of 4 or 5.

Ballistic Skill (BS)

Shows how accurate a warrior is with ranged weapons such as guns and energy weapons. It also includes a measure of the warrior's technical competence with his weapons. The higher this score is the easier a creature finds it to hit when it shoots at something. Some monsters have natural weapons that can be used at range (they may be able to spit venom, for example) and their BS is used to determine whether they hit or not.

Strength (S)

Shows how strong a creature is. An exceptionally puny creature may have a Strength of 1, a deadly Tyranid Lictor has a Strength of 6 and most men have a Strength of 3. Strength tells us how hard a creature can hit in hand-to-hand combat and how easily it can hurt an opponent.

Toughness (T)

Toughness measures a creature's ability to resist physical damage and pain, and reflects such factors as the toughness of its flesh, hide or skin. The tougher a creature is the better it can survive enemy blows or shots.

Wounds (W)

Shows how much damage a creature can take before it either dies or is so badly hurt it can't fight any more. Most humans/human-sized creatures have a Wounds value of only 1. Large monsters are often able to withstand several wounds that would slay a smaller creature and so have a Wounds value of 2, 3, 4 or more.

Initiative (I)

Indicates how alert a creature is and how fast it can react. Creatures with a low Initiative score are slow and cumbersome; creatures with a high Initiative score are much quicker and more agile. In close combat initiative gives faster creatures an edge over slower ones.

Attacks (A)

Indicates the number of Attacks a creature makes during close combat. Most creatures only attack once, although some warriors of exceptional skill or monsters can strike several times. The number of Attacks a creature can make is increased if it has the added impetus of charging into its foe or is fighting using two weapons.

Leadership (Ld)

A creature with a high Leadership value is courageous, steadfast, and self-controlled. A creature with a low value is the opposite! Creatures with high Leadership can lead others, inspiring them on to greater feats of valour.

Save (Sv)

A creature's saving throw gives it a chance of avoiding harm when it is struck or shot. Most creatures have a saving throw based on what kind of armour they are wearing, so their saving throw may be improved if they are equipped with better armour. Other creatures may receive a natural saving throw from having a thick hide or chitinous shell.

0 LEVEL CHARACTERISTICS

Some creatures have been given a '0' for certain characteristics which means that they have no ability whatsoever in that field! This usually applies to creatures who are unable to use missile weapons, and so they have a BS of 0, but it might equally apply to other characteristics too. For example, a defenceless civilian will have no Attacks whatsoever.



In an hour of Darkness a blind man is the best guide. In an age of Insanity look to the madman to show the way.

CHARACTERISTIC PROFILES

Every creature in Warhammer 40,000 has a *characteristic profile* that lists the value of its characteristics. In the Armies Book you will find profiles for many of the races and creatures of Warhammer 40,000. The examples below show the profiles for a Dark Eldar warrior and a Space Marine.

	WS	BS	S	T	W	I	A	Ld	Sv
Dark Eldar	4	4	3	3	1	5	1	8	5+
Space Marine	4	4	4	4	1	4	1	8	3+

As you can see, a Dark Eldar warrior and Space Marine are similar in many respects. They both have the same Weapon Skill and Ballistic Skill which means that they are very evenly matched in combat. When it comes to Strength and Toughness however, the Space Marine wins over the Dark Eldar as his Strength and Toughness are 4 compared to 3. Although not a big difference, the

greater Strength value gives the Space Marine a better chance of injuring or killing the Dark Eldar in hand-to-hand combat. The Space Marine's higher Toughness means he is more able to survive any damage inflicted by the Dark Eldar. The Space Marine's thicker armour gives him a marked advantage over the Dark Eldar and any shot or blow that hits the Space Marine is deflected on a D6 roll of 3 or more. The Dark Eldar however, needs a 5 or more to be saved by its mesh armour.

Both creatures have 1 Wound which is the normal value for man-sized creatures but the Space Marine loses out when it comes to Initiative. This is not a terrible disadvantage, but it does mean that the Dark Eldar warrior will have an edge on the Space Marine once they get into hand-to-hand combat, though the Space Marine's Toughness will make him hard to hurt. Both races have the same Leadership of -8 - better than the average Leadership for Orks and human warriors, which is only 7.



There is a terrible darkness
descending upon the galaxy, and we
shall not see it end in our lifetimes.
Inquisitor Czevak at the Conclave of Har.



A hundred thousand worlds, ten
hundred thousand wars. There is no
respite, there is nowhere to hide.
Across the galaxy there is only war.

UNITS

Warhammer 40,000 allows you to fight battles with armies of troops and supporting units of tanks and guns. It is up to you as general of your forces to find the best way to use your vehicles and infantry to achieve victory. The Citadel miniatures used to play Warhammer 40,000 are simply referred to as models in the rules that follow. Each model is an individual playing piece with its own capabilities.

Of course in real warfare soldiers group together to fight in squads, teams, sections, etc – individual warriors do not normally go wandering off on their own for obvious reasons! In Warhammer 40,000 we represent the way that real troops fight by grouping them together into *units*.

Units of warriors fight in loose groups with gaps between each model. This gives the troopers the freedom to

move over difficult terrain quickly, and enables them to take advantage of such things as minor folds in the ground, scrub, and other small features to shelter from enemy fire.

Similarly, artillery batteries consist of the guns and the crew that fire them, vehicle squadrons are made up of a number of light vehicles and so on. The different elements of the unit have to stay together to remain an effective fighting force. This is detailed more fully in the rules that follow.

A unit will usually consist of several infantry models or small vehicles that fight as a group, but it can also be a single, very large and powerful model such as a battle tank, a monstrous alien creature or a heavy gun and its crew. In the rules that follow all of these things are referred to as units.

Units can have very different capabilities so are divided into four types: *infantry*, *vehicles*, *cavalry* and *bikes*.

Infantry includes all squads of foot troops, whether human or alien. A typical unit of troops is between five and ten warriors strong. Infantry can cross almost any terrain (given enough time) and make the best use of cover to avoid enemy fire. Most large bipedal creatures such as the Tyranid Carnifex are counted as infantry although they are usually individual models.



Bikes are infantry units mounted on machines. They move rapidly and gain extra protection from their armoured steeds. Bikes usually carry better weapons than foot-slogging infantrymen.



Vehicles include all war machines – Land Raiders, Rhinos, Dreadnoughts and Ork Buggies all fall into this category. Vehicles can move more rapidly than infantry but need to stick to open ground to avoid getting bogged down. Vehicle units are represented by single models in the case of tanks and other large vehicles or as a group of smaller vehicles. Vehicle crew members such as drivers, commanders and gunners are assumed to be an integral part of their machine, if the vehicle is destroyed they are killed along with it.

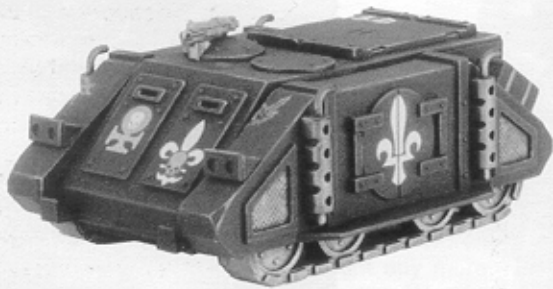

Cavalry includes all units of infantry mounted on steeds of any sort – horses, boars, daemoniac creatures etc. A cavalry unit is typically five models strong and operates in much the same way as an infantry unit, although it is faster moving into an assault than foot troops.



IMPORTANT: The basic rules that follow deal with the core rules for infantry. Vehicles, bikes and cavalry get their own specific rules sections later.

THE TURN

A Warhammer 40,000 battle is unlike other games such as chess or draughts where you only move a single piece at a time. A tremendous amount of action takes place in a battle: squads manoeuvre and fire, tanks rumble into action and artillery fire roars down from overhead in a torrential downpour of destruction.

In a real battle this all happens at once amidst the confusion and chaos of combat. A Warhammer 40,000 game represents the whole ebb and flow of battle but in order to determine its outcome players alternate taking turns moving and fighting with their troops. So in a battle player A will move and fight with his forces first, then player B will move and fight, and then player A will move and fight again and so on.

During his turn the player can move and fight with **all** of his troops if he wishes. For convenience the actions of moving, shooting and fighting are dealt with one after the other. This means you move any troops and vehicles you want to first, and then you shoot with anyone who can and so on. This process helps everyone to keep track of what is going on and makes it easier to know when one player's actions are over and their opponent can start taking his turn.

In a complete turn each player performs their actions in the appropriate phases – the move, shoot and close assault phases to be precise. Exactly what happens in each phase is described in the turn sequence (opposite).

WHO GETS THE FIRST TURN

Which player gets the first turn of the game can be determined in a number of different ways. Normally both players roll a D6 and the player with the highest score can decide to move first or second (first being a popular choice unless you have a *really* cunning plan). Sometimes the kind of game you are fighting will decide it for you. For example, in an ambush the attacking side will always get the first turn.

Fighting all sorts of different battles is covered in more detail in the Battles Book.

ENDING THE BATTLE

A battle can end in a number of ways. One of the most common is having a pre-set number of turns. Most games are set to a limit of six turns for each player.

However, in some kinds of battle players might be able to win a 'sudden death' victory which ends the game immediately – eg if they destroy the power generator they win straight away. Alternatively the number of turns being fought might be random, determined by a dice throw. You could also decide to end a battle at a preset time if you only have a limited amount of time to play in.

Different ways of ending the battle are discussed in more detail in the Battles Book.

EXCEPTIONS

There are times when a player performs actions when it is not their turn, such as fighting in a close assault for example. It may also be convenient to interrupt a player's turn because of some event occurring like a booby trap being triggered. The thing to remember is that after the interruption the turn sequence always continues as normal.

THE TURN SEQUENCE

MOVE

The player can move any of his units that are capable of doing so (eg they're not stuck in a swamp or something). See the Movement rules for more details of how to move your forces.

SHOOT

The player can shoot with any of his units that are within range of the enemy. See the Shooting rules for more details about how to resolve shooting.

CLOSE ASSAULT

The player can move any of his units in to assault the enemy if they are close enough. Close assaults are bloody, desperate affairs where troops are fighting in hand-to-hand combat and shooting at a very close range. This means that both forces can fight in a close assault phase, but only the player whose turn it is can move troops. The Close Assault rules will tell you more about assaults.

THE MOVEMENT PHASE

The Movement phase is your chance to move your troops. For example you can send them into the attack, move them in to cover, retreat from a superior foe or sweep around an enemy's vulnerable side or rear. Although the movement phase is the easiest to perform, it's probably the most important.

For the time being we'll just explain how warriors on foot move as they are by far the most common units in the game. Vehicles, bikes, cavalry and other units move in different ways to represent their greater mobility and these will be discussed in detail later.

There can be no bystanders in the battle for survival.
Anyone who will not fight by your side is an enemy you must crush.

Scriptorus Munificatus

MOVING UNITS

In his turn a player may move each unit up to its standard Move distance. Once one unit has completed all of its move, the player selects another and moves that one, and so on until the player has moved all of the units he wishes to move. This can be summarised as:

- 1 Choose a unit to move.
- 2 Move the unit up to its maximum move distance.
- 3 Choose another unit to move.

Note that a player doesn't have to move all (or indeed any) of his units. A unit that doesn't move is often more effective at shooting, as we will explain later in the rules.

MOVEMENT DISTANCE

Warriors on foot move 6 inches (6") in the movement phase. This represents most creatures moving at a run but stopping several times to observe the surrounding landscape for enemies, snap off a few quick shots with their weapons and so on.

Even warriors who are moving in a part of the battlefield where no enemies may be apparent move 6". This is because your troops lack your own god-like knowledge that there is no enemy around.

A player cannot position a model so that it touches an enemy during the move phase – he must wait until the assault phase to do so. Opposing models must be left at least 1" away in the move phase to keep things clear.



MOVING MODELS IN A UNIT

As mentioned before, units are often groups of warriors operating together. They fight in a loose formation with gaps between each model. This gives the individual troopers freedom to move quicker over difficult terrain, and enables them to take advantage of cover.

When you are moving a unit the individual models in it can move by any amount up to their maximum Movement distance. Remember that units have to stick together otherwise individual troopers or vehicles become scattered as the squad loses its cohesion as a fighting unit.

Once a unit has finished moving, the models in it must form an imaginary chain where the distance between one model and the next is no more than 2".

During the course of a game it's possible a unit will get broken up, usually because it takes casualties or individual models are engaged in close combat. When this happens the following rule applies:

If a unit is broken up for any other reason the models in it must be moved to restore coherency in the next movement phase. If they can not do so then the unit may not shoot or launch an assault until it is in a coherent formation again.

Models engaged in close combat are not bound by the above rule. Once combat has finished the unit must form up again.

Turning and Facing

As you move models in a unit they can turn by any amount without any penalty to the distance they are able to cover. Models are turned to face their targets in the shooting phase so don't worry about which way they are pointing at the end of their movement phase (although dramatically facing off against their foes is traditional).

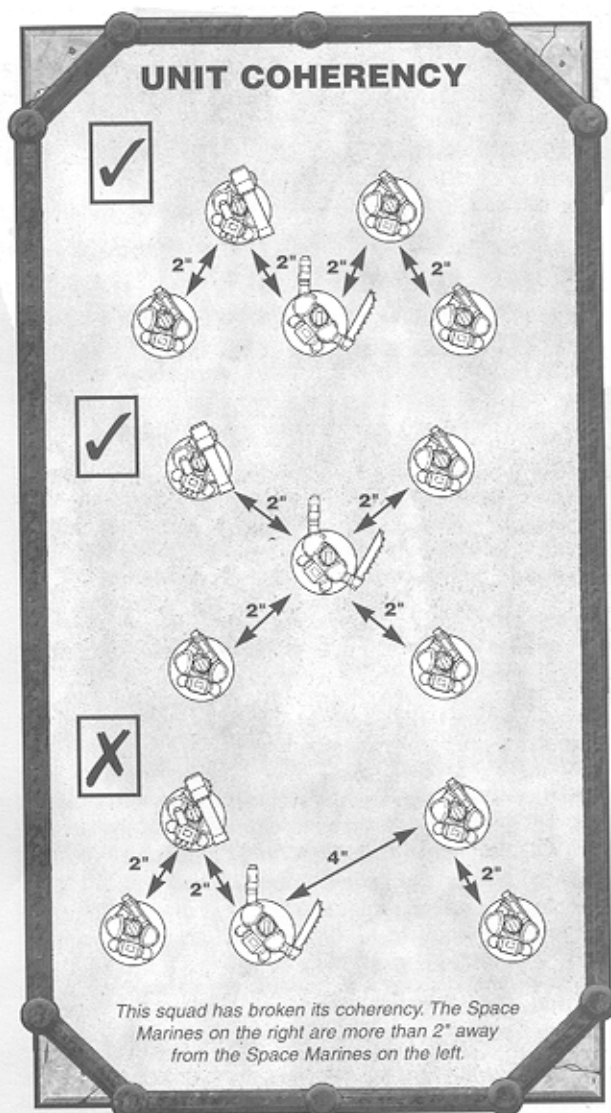

TERRAIN

The galaxy is a vast place with millions of different worlds: ice worlds, desert worlds, hive worlds, feral worlds and more others than can be easily enumerated. The terrain covering these worlds can vary from broad, empty plains to sky-scraping towers of plexiglass and plas-steel, from verdant jungles to icy peaks or baking hot deserts.

One factor is common to all of them, they all have areas seemingly designed to make it difficult to wage war. Of course areas that provide cover where warriors can fight or which present an obstacle to the enemy are vital in war, and these are destined to become the bloodiest battlefields.

How to represent terrain on the battlefield is discussed further in the Battles Book. For now we're going to discuss terrain only in relation to troops moving through it.

Though the Imperium of Man extends from one edge of the galaxy to the other it is spread unimaginably thinly – its worlds divided by thousands of light years of empty oceanic space. There are over a million star systems within the Imperium – yet this is but a tiny fraction of the number of stars in the galaxy. The Imperium is constantly discovering new worlds and uncovering ancient human colonies settled thousands of years ago during the time of the Stellar Exodus. Doubtless there remain countless new worlds and undiscovered races that lie beyond the knowledge of the Imperium.

CLASSIFYING TERRAIN

At the start of a game you will need to have a look at the areas of terrain on the tabletop and decide how difficult they will be to traverse. Don't panic! There's a list of examples below. It's best if you can agree the terrain with the person you're playing against, but you can always roll dice for any areas you're not sure about.

Terrain is classified into three types: *normal*, *difficult* and *impassable*.

Normal. Grassland, crops, moors, most hillsides, streets, buildings, gantries, ladders, steps, fields, open woods, sparse brush or bushes, sand, rocky plateaus, craters, ice sheets, scattered rocks or monoliths, most ruins and low walls, most streams and rivulets.

Difficult. Sand dunes, loose ash or clinker slopes, steep hillsides, thick mud, dense or tangled woodland, thick vegetation, jungles, deep snow, marsh, peat bogs, waist-deep water (or other harmless liquids), unstable piles of rubble.

Impassable. Very steep slopes and cliffs, high walls, bottomless dust pits, geysers, lava, swamps, tar pits, sludge pools, toxic waste, very deep water.

TERRAIN EFFECTS

Units moving through dense terrain tend to slow down or stop altogether. They may become temporarily lost and need to find their bearings or could be physically slowed down by picking their way through difficult ground full of potholes and tangling vegetation. This means that units sent into some areas are not entirely under the control of the force commander (ie you) any more.

Normal. Standard rules apply, no additional effects on moving troops.

Difficult. A unit of troops that is moving into, out of, or through difficult terrain rolls two D6 and uses the highest roll as the maximum distance it may move that turn.

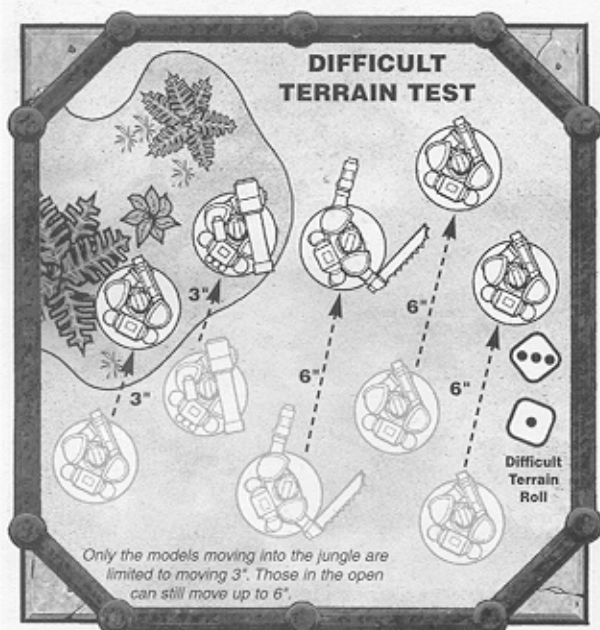

It is not the Horror of War that troubles me but the Unseen Horrors of Peace.

If the dice roll is not high enough for the models to move into difficult terrain, place them just inside its edge. Any models in the unit which don't actually move in difficult terrain still get a full 6" move, but remember that they must form a continuous chain with the rest of the unit that is in difficult terrain.

Impassable. Can't be moved through at all unless the troops have special training, supernatural abilities and/or the right equipment. Where this is the case it will be noted in the troops' or creatures' description.

Varying Terrain Difficulty

You might want to try making various sorts of terrain harder or easier to move through for extra variation. This is easily done: simply roll one, two or three D6 for a unit moving through the terrain. You must decide first on how tough you think the terrain should be. The more dice you roll the easier the terrain is to move through – so you might decide a muddy field is three D6 while a tidal mud flat is one D6. This can also be used to represent moving on worlds with particularly high or low gravity in comparison to Earth – for example on a high gravity world you might decide that you roll three D6 and pick the highest for movement even when you are crossing open ground.

On this chart there are examples of what effect different terrain has on troop movement. In addition you may want to have a look at the random Terrain Generator charts in the Battles Book section.

TERRAIN	EFFECT
Sand or ash dunes	3D6*
Muddy or water-logged ground	3D6*
Ice, thin ice**	3D6*
Thick bracken, dense undergrowth	2D6*
Steep hillsides, magnetic anomalies	3D6*
Dense woodland, jungle	2D6*
Rubble, slag heaps, crumbling rock	2D6*
Thick mud, deep snow, deep water	1D6
Marsh**, peat bogs**	1D6
Boiling mud****, tar pits****	1D6
High gravity world, strong winds	-1D6****
Sand storms, chemical storms***	-1D6****
Low gravity world	+1D6

* Pick highest score on any one dice to find distance moved.

** Models ending move in terrain are destroyed on a D6 roll of 1.

*** Models ending their move in terrain must make an armour save or suffer 1 wound.

**** Normal movement is reduced by D6*. Count clear terrain as difficult terrain.

THE SHOOTING PHASE

In the shooting phase you have the opportunity to fire at the enemy with your forces. In a real battle the guns thunder unceasingly and there is an almost constant exchange of fire between foes. To represent this in a Warhammer 40,000 battle we split the firing up so that each player fires during their own turn. This makes shooting simple to work out and keeps the game moving at a good pace.

In the shooting phase each of your units may fire. You can choose any of your units to shoot with but you must complete all the firing by one unit before you move on to the next. Each model in a unit can shoot with one weapon each. The whole unit has to fire all of its weaponry at a single enemy unit of your choice, you may not split fire between two or more target units. The shooting process can be summarised into the following five steps.

Once you have completed this sequence with one of your units select another unit and begin at step 1 again. Once you have completed steps 1 to 5 for each unit in your army you have finished shooting and can move on to the assault phase.

The rules for the shooting phase also includes details on weapons. These appear later on in this section.

- 1 **Choose a target.** Select an enemy unit for one of your units to fire at.
- 2 **Measure range.** See if the target is within range of the weaponry of your firing unit.
- 3 **Roll to hit.** Roll a D6 for each shot fired by the firing unit. The model's BS determines what score they must equal or beat to hit their targets.
- 4 **Roll to wound.** Roll again any dice that hit to see if the shots wound their targets. The score needed is determined by comparing the Strength of the firing weapons to the Toughness of the target.
- 5 **Remove casualties.** The target unit's owner removes any casualties but attempts saving throws for models that have been wounded. Models in cover can always attempt a saving throw.

1. CHOOSE A TARGET

As mentioned before, a firing unit can choose a single enemy unit as its target. There are several considerations when choosing a target: namely can your unit see it and will their weapons have enough range to reach it?

LINE OF SIGHT

You can only select an enemy unit as a target if your unit can see it, or at least part of it. Obviously a unit cannot open fire if there is a hill, building, or some other large object in the way.

Sometimes it may be hard to tell if a *line of sight* is blocked or not, so players must stoop over the table for a 'model's eye view'. This is the best way to see if a line of sight exists.

Models in the attacking unit do not block a line of sight (they duck, crouch or get out of the way). Likewise ignore units from your own side (your unit conducts its firing at a convenient moment when their compatriots are not in the way). Enemy models and all vehicles, friend or foe, do block a unit's line of sight if they are in the way, just like buildings and other terrain. Enemy models will block the line of sight to other models up to twice their height.

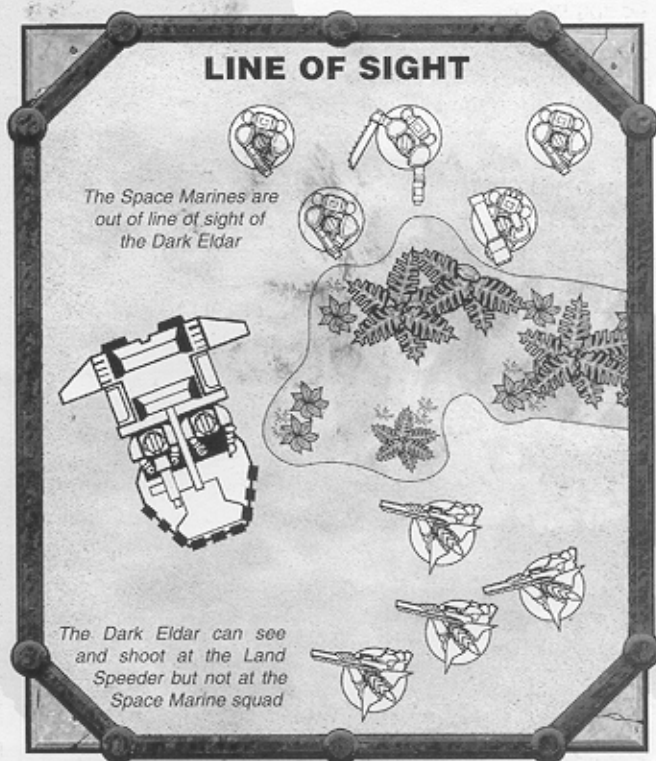

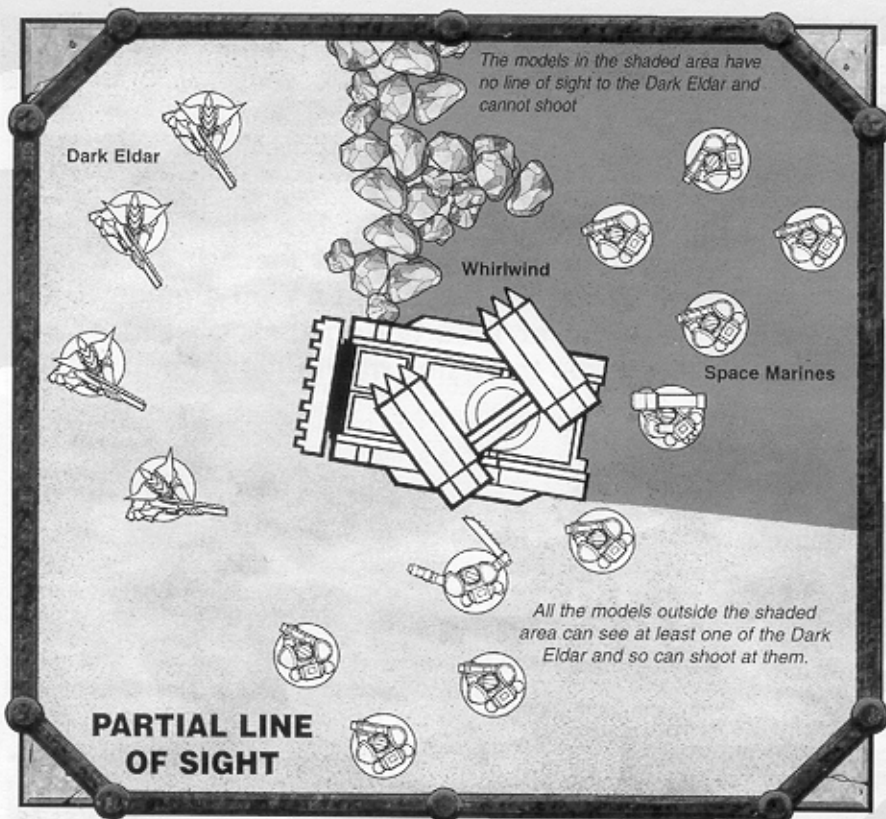

Individual models in the unit that don't have a line of sight to the target unit cannot fire, and any models in the target unit that cannot be seen by their attackers cannot be hit by their firing.

Woods and Jungles

Not all kinds of terrain will completely block line of fire. Areas of terrain such as trees, shrubs, bushes and other similar plant-like obstructions will tend to form a 'grey area' where the enemy fades out of sight the further in they are.

The model terrain used to represent woods and jungles is made so that models can be moved into and through it. In reality woods and jungles would be overflowing with all kinds of greenery (or its alien equivalent) so in this case the usual rules for spotting targets using the model's eye view do not really work.

In woods and jungle it is possible for a model to see up to 6" into areas of woods, jungles or similar terrain. Models that are further than 6" into the terrain cannot be seen at all, or see out themselves. If both firer and target are within the same area of vegetation they can only see each other if they are within 6".

Note that although it is possible to see *into* an area of woods or jungle you cannot see *through* it even if it is less than 6" deep. So, if a unit is behind an area of woods or jungle they cannot be seen at all by anyone on the other side.

As a final note you may want to vary the distance that troops are visible in woods or jungles to their enemy. For example you could try reducing visibility to only 2-3" for very dense growth or increase it to 8-12" for sparse woodland.

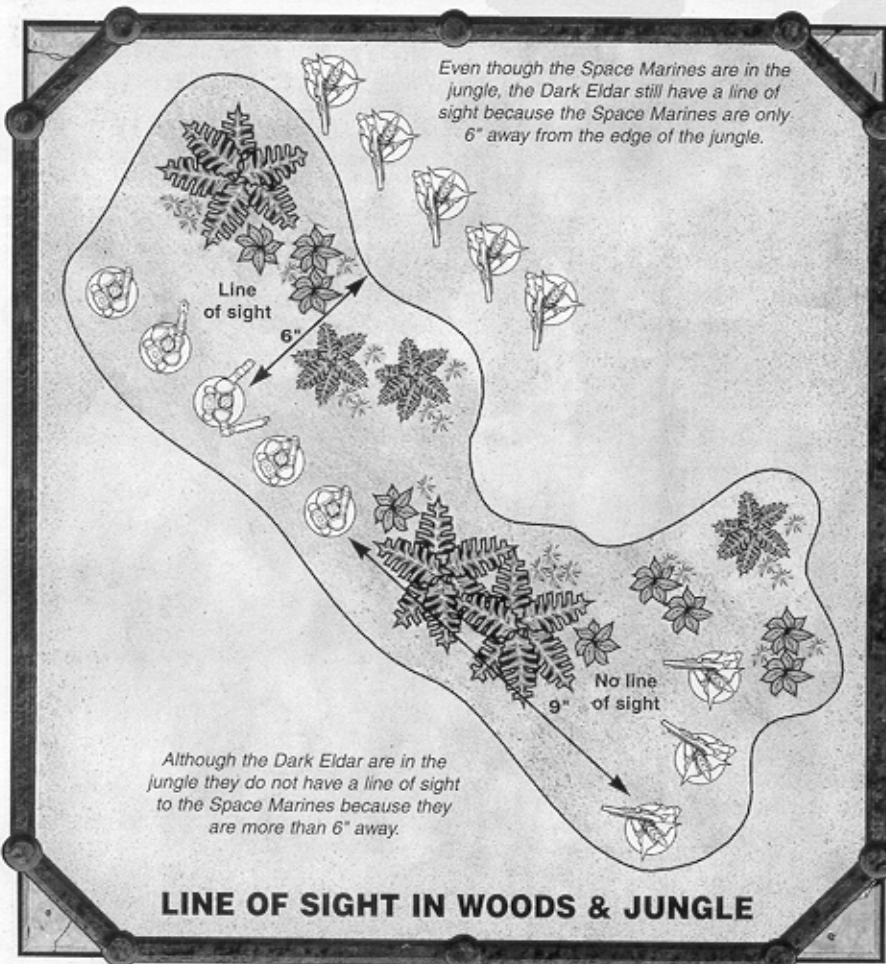

2. CHECK RANGE

All weapons have a maximum effective range that tells you the furthest distance they can shoot. If your target is beyond this maximum range then your shot misses automatically. This is why you have to choose your target before measuring the range.

Weapon	Maximum Range
Shuriken Catapult	12"
Laspistol	12"
Boltgun	24"
Autocannon	48"

When checking range, measure to the nearest model in the target unit. Models in that unit who are out of range cannot be hit, as described in Casualty Removal later.

When a unit fires, measure the distance for each model in the unit. Any that are out of range may not shoot.

Moving and Shooting

Whether or not a unit has moved can make a big difference to its firing. If the warriors hold a position, take up firing stances and aim at their targets properly they can hit targets further away than if they are firing on the move. In fact some weapons are so heavy they can *only* be used if their firer halts to brace themselves. For the time being it's enough to know that moving makes a difference to a unit's shooting. The most important thing to understand is that the **whole unit** counts as moving even if only some of it moved in the movement phase.

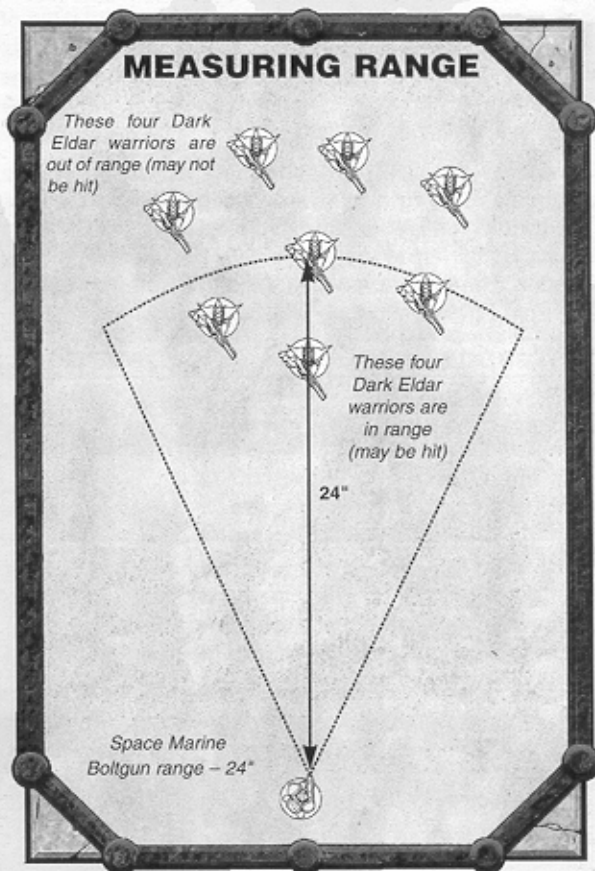

3. ROLL TO HIT

To determine if the firing unit hits their target roll a D6 for each shot. Normally troopers will get to fire only one shot each, however they can fire more than one shot with particular weapons as we'll explain in more detail later. For the present just assume that each trooper fires one shot so they each roll one dice to hit.

The dice score needed to hit will depend on how accurate the firers are (as shown by their Ballistic Skill characteristic or BS). The chart below shows the minimum D6 result needed to score a hit.

BS of Shooter	1	2	3	4	5	6	7	8	9	10
Score to Hit	6	5+	4+	3+	2+	2+	2+	2+	2+	2+

For example, if the shooters are a unit of five Space Marines with a BS of 4, you would roll 5 dice and each roll of a 3 or more would score a hit.

To hit rolls are **easy** to remember as you just subtract the BS of the shooter from 7. This will give you the number you need to hit. For example, a model with a BS of 2 needs (7-2=5) 5 or more on a D6 to hit.

As you can see, the minimum dice roll needed to hit is always at least 2. There is normally no such thing as an automatic hit, a roll of a 1 always misses. Ballistic Skills of more than 5 are shown for comparative purposes; they are used fully in the Warhammer 40,000 Skirmish series games.

Rolling Dice to Hit

When a unit fires roll all of its To Hit dice together. Sometimes there will be different weapons firing, or firers with different BS in the same unit and you might find it convenient to use different coloured dice for them so that they can be picked out easily. For example you could use green dice for all shots with plasma weapons and red dice for all shots with melta weapons. Alternatively you can simply make separate dice rolls for different weapons or shooters. As long as it is clear which dice rolls are for which shots you can use any convention for this that you like.

A dagger in the dark is worth a thousand swords at dawn.
Tactica Imperium

4. ROLL TO WOUND

Hitting your target is not always enough to put it out of action. Not all hits cause damage and some targets can take quite a bit of damage before they are destroyed. A hit might result in nothing more than a superficial graze or flesh wound.

To decide if a hit causes damage, compare the weapon's **Strength** characteristic with the target's **Toughness** characteristic. Each weapon has its own Strength score as given in the description of the weapon. Here are some examples of different weapons and their Strength characteristics.

Weapon	Strength
Splinter Rifle	3
Boltgun	4
Melta Gun	8
Lascannon	9

To work out the damage caused by the weapon consult the following Damage chart. If you cross reference the weapon's Strength (S) with the target's Toughness (T) the resulting number is the minimum D6 result needed

to convert the hit into damage. As with shooting roll the dice together and once again you can use different coloured dice to represent different weapon strengths.

If this roll is successful the target has been **wounded** and is removed as a casualty. Casualties are not necessarily dead, they may be merely knocked unconscious or incapacitated in some way. In any case, they are no longer fit to participate in the battle.

Note that **N** on the chart means that the hit has no effect. A target with the Toughness indicated cannot be harmed by a hit of such a puny strength.

EXAMPLE: A Space Marine armed with a boltgun shoots at an Ork and hits him. A boltgun has a Strength of 4 and the Ork has a Toughness of 4. Referring to the chart a score of 4 or more is needed to convert the hit into damage. If the dice roll is 4 or more then the Ork takes a wound – as he has only 1 wound in the first place this means that he will be 'killed' and removed from play.



Through the destruction of our enemies
we earn our salvation.



DAMAGE CHART



		TOUGHNESS									
		1	2	3	4	5	6	7	8	9	10
STRENGTH	1	4+	5+	6+	6+	N	N	N	N	N	N
	2	3+	4+	5+	6+	6+	N	N	N	N	N
	3	2+	3+	4+	5+	6+	6+	N	N	N	N
	4	2+	2+	3+	4+	5+	6+	6+	N	N	N
	5	2+	2+	2+	3+	4+	5+	6+	6+	N	N
	6	2+	2+	2+	2+	3+	4+	5+	6+	6+	N
	7	2+	2+	2+	2+	2+	3+	4+	5+	6+	6+
	8	2+	2+	2+	2+	2+	2+	3+	4+	5+	6+
	9	2+	2+	2+	2+	2+	2+	2+	3+	4+	5+
	10	2+	2+	2+	2+	2+	2+	2+	2+	3+	4+

5. REMOVE CASUALTIES

"Be vigilant and strong. The Emperor knows what evil lurks in the vacillation of a weak fool."

Once the number of hits and wounds has been determined the player owning the target unit must remove any casualties that have been inflicted. This means that the owning player gets to choose who is hit by the enemy's firing. Assuming that the models in the unit have 1 wound each, one model is removed for each wound inflicted.

Note that you can't choose to lump all of the wounds together onto one model!

The owning player can remove any models from the unit, providing they're within range of the attacker's weaponry. He can even remove models from the rear of the unit – these troops were slain as they advanced and the rest of the unit continued moving forward. Likewise powerful weapons will be picked up by other members of the unit and so on, so it's perfectly fair for a player to avoid taking casualties on (for example) heavy weapons or squad leaders if he doesn't want to.

TAKING ARMOUR SAVES

Before he removes models as casualties the owning player can test to see if they survive being hit because their armour stops or deflects the shot. Most troops wear some sort of protective clothing or armour – even if it's only a helmet! If a model is wearing armour it is allowed a further dice roll to see if the armour stops him being wounded. This is called a **saving throw**.

To see if armour successfully stops damage roll a D6. The following table shows how the minimum D6 score required varies between the different types of armour.

Armour Type	Minimum D6 score required to save
Terminator Armour	2
Space Marine Armour	3
Imperial Guard Flak	5
Eldar Aspect Armour	4
Eldar Mesh Armour	5
Ork Body Armour	6
Ork 'Eavy-Armour	4
Ork Mega-Armour	2
Dark Eldar Incubi Armour	3
Tyranid Warrior Carapace	5

If the player rolls a D6 and gets equal to or greater than the score required it stops the wound.

EXAMPLE: A Space Marine wearing power armour is hit and wounded. The Space Marine is entitled to a saving throw of 3 so he rolls a D6, scoring 5. The damage is therefore saved, and the model is unharmed, the shot bounces harmlessly off his armour.

When a unit takes a number of wounds from an enemy unit shooting at it you can roll all saving throws together. The owning player then simply removes the wounded models all at once.

Weapons can often pierce lighter types of armour and particularly devastating weapons make a mockery of even the heaviest armour. This is explained in more detail later.



ARMOUR OF THE 41st MILLENNIUM

Most troops wear armour to protect themselves from weapon fire and the blows of their enemies in hand-to-hand combat. Armour greatly affects a warrior's chance of survival and so influences the outcome of combat. The more heavily armoured troops are, the harder they are to kill. With the advent of lightweight armaplas alloys, ceramics and synthetic fibres there

is no movement restrictions for warriors wearing a great deal of armour. However, the limited availability of certain kinds of armour, in particular power armour, ensures that it is only used by the best troops. Armour ranges in effectiveness from the simple flak jacket to the immensely powerful tactical dreadnought armour of the Space Marines.

POWER ARMOUR

This is a completely enclosing suit of armour as worn by Space Marines. It is made from thick ceramite plates and would be heavy and cumbersome but for electrically motivated fibre bundles implanted in the armour that replicate the movements of the wearer and supplement his strength. Power armour is fully sealed to provide protection against gas weapons and harsh atmospheres. It also commonly includes numerous auxiliary systems such as communicators, auto-senses etc.

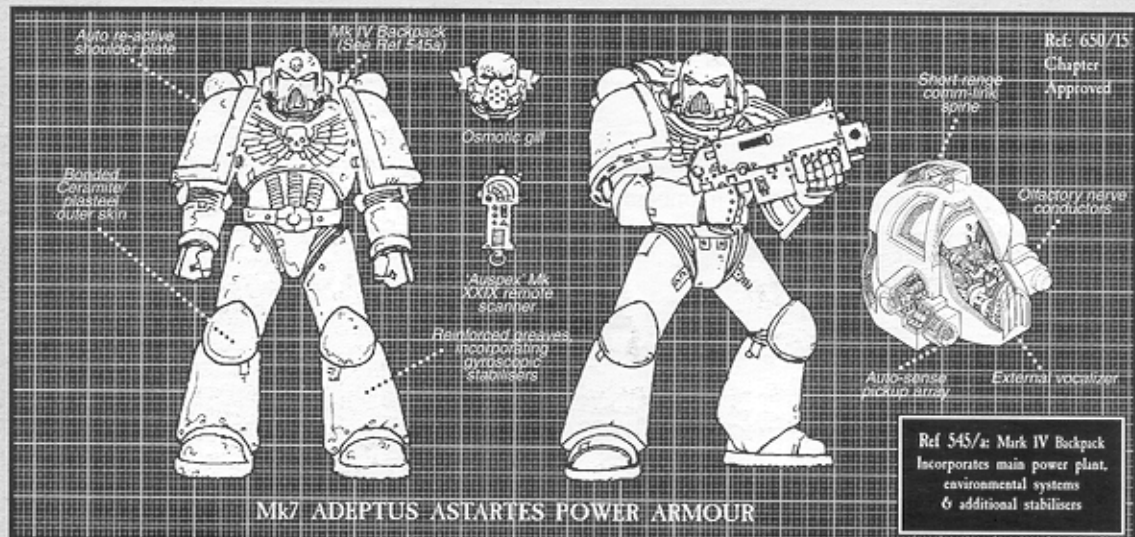

TERMINATOR ARMOUR

Tactical Dreadnought armour, or Terminator armour as it is more commonly known, is the best personal armour in the galaxy. The armour itself is massively bulky so it contains a full exo-skeleton of fibre bundles and adamantium rods. These support the heavy gauge plasteel and ceramite plates which form the outer carapace. The immense power of the Terminator suit means that troops using it can wield the heaviest weapons without restriction, handling autocannons and missile launchers like an ordinary man would handle an autogun or a bolter. The secrets of the manufacture of Terminator suits are known only by a few, so the ones that remain are very valuable and old and are reserved for use by only the most highly trained brethren of the elite Space Marine Chapters.

A warrior's faith in his commander is his best armour and his strongest weapon.

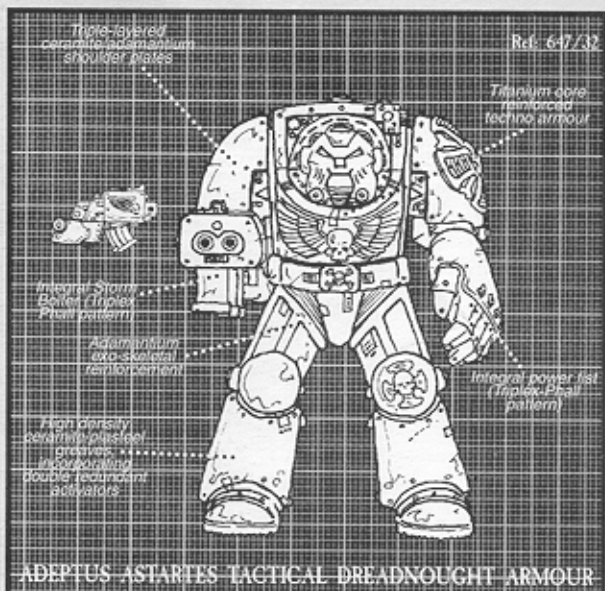



MESH ARMOUR

Mesh armour is formed of tens of thousands of individual pieces of thermoplas interwoven to produce a dense material rather like reptile scales or archaic chainmail. When struck the mesh becomes momentarily rigid, spreading the impact across a larger area. The thermoplas material also disperses heat rapidly, giving reasonable protection against energy weapons. Mesh armour is commonly used by the alien Eldar.

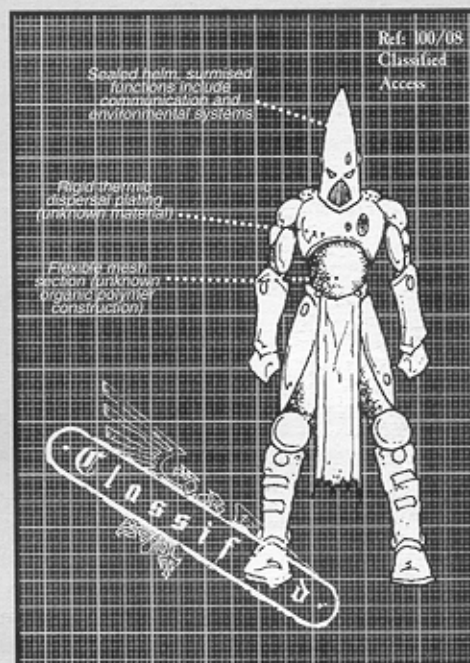

FLAK ARMOUR

Flak armour comprises several layers of different ablative and impact absorbent materials which should absorb the majority of energy from a shot. Flak armour is cheap and easy to produce, requiring a very low technology base. Flak armour is mainly used by the Imperial Guard.

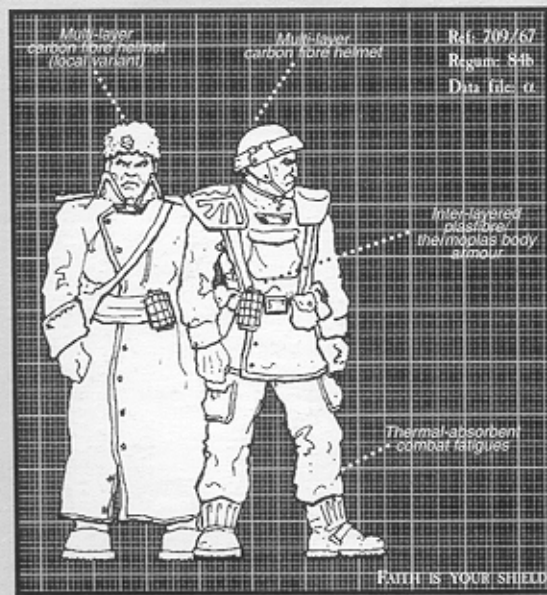

By means of their ancient genetic-replication vats the High Technomagi of Mars are able to extend their lives for thousands of years. Thus these shrivelled husks maintain their stranglehold upon the secrets of technology that lie buried beneath their planet's surface. Tragically their minds continue to decay, and as the centuries pass they grow increasingly insane as their grip on reality slips into a miasma of superstition, blood-sacrifice and madness.

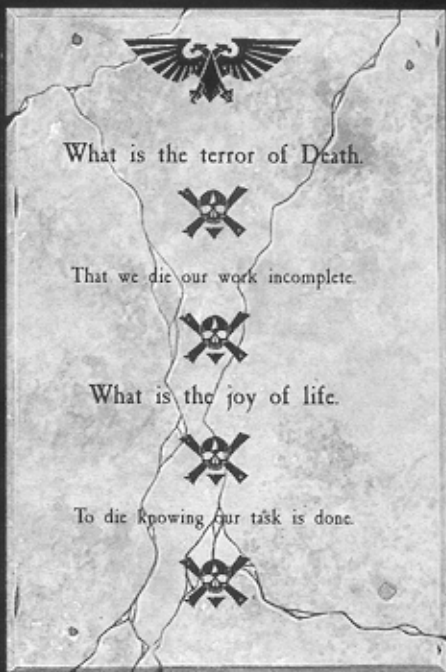

ALLOCATING HITS

The Space Marines shoot and score four hits

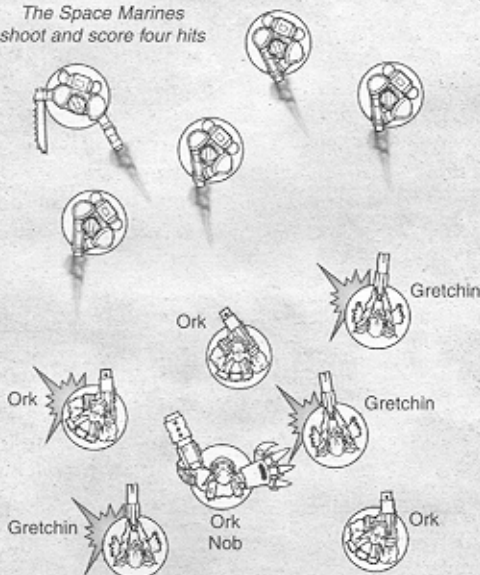

The Ork player allocates three hits to the Gretchin (T2) and one to an Ork (T4) before his opponent rolls to wound.

Units With More Than One Toughness Value

Sometimes a unit will contain creatures with different Toughness characteristics. When this is the case allocate hits **before** rolling to wound. You may only allocate one hit against each model until all of the models in the unit have taken one hit each.

MORALE CHECKS - CASUALTIES FROM ENEMY FIRE

Enemy fire will make even the hardest troops waver if their comrades start to fall in great numbers. Outright flight is unlikely and unwise in the face of intense opposition but even the most seasoned veterans may fall back to regroup and reconsider their tactics if they suffer too many casualties.

In Warhammer 40,000 such events are represented by units taking Morale checks when they suffer casualties in the Shooting phase. Any unit losing 25% or more casualties from its current strength to shooting during a shooting phase must make a Leadership test to hold their ground. Morale checks, falling back and regrouping are covered in more detail later.

Hope is the first step on the road to disappointment.

CREATURES WITH MORE THAN 1 WOUND

Especially tough and heroic individuals such as Space Marine commanders or horrendous alien monstrosities like Tyranid Lictors can sustain more damage than ordinary troopers and carry on fighting. To show this they have more than 1 Wound on their characteristic profile.

When a creature like this suffers a wounding hit it loses 1 Wound. Once a creature has lost all of its Wounds it is removed as a casualty. For example, a creature with 3 Wounds would only be killed after it had been wounded three times. Keep track of how many Wounds a creature has left on a piece of scrap paper or by placing a dice or marker next to the model (Jervis has made little model gravestones for his Wound markers!).

Instant Death!

Even though a creature might have multiple Wounds there are plenty of weapons in the 41st Millennium that are powerful enough to kill instantly. If a creature is wounded by something that has a Strength value that is **double** its Toughness or greater it is killed outright and immediately removed. It can be imagined they are vapourised, burned to a pile of ash, torn limb from limb or otherwise mortally slain in a suitably graphic fashion.

EXAMPLE: A Space Marine commander is Toughness 4 and has 2 Wounds. Normally he could survive being wounded twice before being removed as a casualty. However, if he were to have the misfortune to be hit by a Krak missile (Strength 8 – normally used for knocking out battle tanks) he would become a casualty immediately because the missile's Strength is double his Toughness – he just isn't that tough!

Armour Saves and Multiple Wounds

Creatures that have multiple Wounds take their armour saves just as ordinary troops with only 1 Wound do. If they make their save they suffer no damage but if they fail they suffer 1 Wound. Against instant-death Strength weaponry a save can still be attempted (assuming the weapon doesn't have a good enough Armour Piercing value to just punch straight through their armour). If the save is made the shot ricochets harmlessly off the model's armour or cover (phew); if it fails the model is removed as a casualty (urgh!).

Casualty Removal and Multiple Wounds

If a unit is made up of creatures with multiple Wounds you have to remove whole models as casualties where possible. This is a convenient method which saves on both brain cells and book-keeping. For example, if you had a unit of Ork Nobz (hulking great things with 2 Wounds each) which suffered 5 Wounds from bolter fire, you would remove two models as casualties and note down or place a dice by the unit to indicate that 1 Wound was carried over. If the unit later took another Wound you would have to remove another Ork Nob.

If the hits are powerful enough to kill outright take off one model as a casualty for each wounding hit inflicted. For example, Ork Nobz are Toughness 4, so a lascannon (Strength 9) can kill one Ork Nob with each hit. Hence two lascannon hits on a unit of Ork Nobz would remove two Nobz as casualties. Note that these 'instant kills' do not affect Wounds that are being carried over, these are retained so that they can be made up to full kills by other less powerful hits.



ARMOUR PIERCING

Powerful weaponry is quite capable of punching through different types of armour. This is shown by a weapon's **Armour Piercing** value. Nearly all weapons have an Armour Piercing rating. This is most commonly 6, but potent weapons like bolters and heavy weapons might have values of 5, 4 or even less. Some sample Armour Piercing ratings for different weapons are shown below.

Weapon	AP
Splinter Rifle	5
Boltgun	5
Heavy Bolter	4
Lascannon	2

The lower the rating the better, because it indicates the armour save the weapon can defeat and automatically punch through. So, a bolter with an Armour Piercing rating of 5 automatically pierces armour which has a save of 5 or 6; a lascannon with its Armour Piercing rating of 2 automatically pierces armour which has a save of 2, 3, 4, 5 or 6.

If the weapon's Armour Piercing value is sufficient to punch through armour as described then the target gets no save at all. The armour is ineffective against the shot.

If the weapon's Armour Piercing value is not able to automatically punch through the armour then the target can attempt to save as normal.

EXAMPLE: A bolter has an Armour Piercing value of 5 so Armour saves of 5 or 6 are automatically ignored. Saves of 4+ are taken as normal.

Invulnerable Armour Saves or "Our weapons are useless!"

Some creatures or entities are protected by more than mere physical armour. They may be shielded by force fields, enwrapped by mystic energies or have an alien metabolism that can shrug off hits which would put holes in a battle tank. Models like these are referred to as **invulnerable** and always get their saving throw even if the Armour Piercing value of the weapons hitting them would normally defeat their armour. Even if a hit normally ignores all armour saves, an invulnerable model gets to try and make its saving throws as normal.

Sometimes a creature has a normal armour save and a separate invulnerable armour save – a good example of this is a Space Marine Chaplain who is protected by power armour and a forcefield. In cases where an invulnerable save is also available the owning player must decide which armour save to use before rolling the dice as the model will still only get to make one saving throw.



To a Space Marine the boltgun is far more than a weapon, it is an instrument of Mankind's divinity, the bringer of death to his foes, whose howling blast is a prayer to the gods of battle.

COVER SAVING THROWS

When the air is full of bullets and shrapnel some good solid cover to lurk behind is always welcome. A position in cover shields troops against flying debris, shots, blasts and shrapnel, enabling them to get their heads down or crawl amongst rocks and (hopefully) avoid harm. In a battle models in or behind cover get a saving throw of 5 or 6 on a D6, or a saving throw from their own armour, whichever is better.

The great thing about cover saving throws is that they are not affected by the Armour Piercing value of the weapons firing, so troops in cover will normally get a saving throw regardless of what is firing at them.

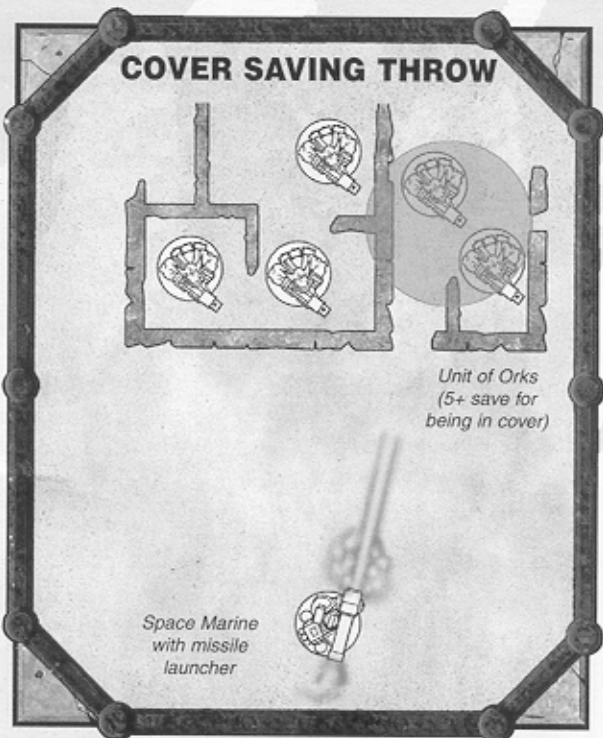

EXAMPLE: A Space Marine with a missile launcher fires a frag missile (Armour Piercing 6) at a unit of troops who are using some ruined walls as cover.

If the troops were Orks (save 6) they'd use the 5+ saving throw for being in cover as it is better than their armour save (which would be useless against the frag missile anyway).

If the troops were Space Marines (save 3) they would get a 3+ saving throw because the frag missile doesn't pierce their armour and their own save is better than the cover save.

What Counts as Cover?

It is hard to be completely definitive about what counts as cover, different players will have access to all sorts of different terrain so common sense is the best guide. The main criteria is that cover has to be reasonably substantial. Basically it is up to the players to define what constitutes cover in their games, but here's a guide to some of what we designate as cover.

Crates, Rocks, Woods, Jungles Ruins, Buildings and Vehicles

Cover which is notably more or less substantial than these can have a different saving throw value if you choose. For example, really light cover such as high grass or a chain link fence that conceals troopers rather than protects them gives a cover save of 6+. Fortified bunkers, trenches or heavily reinforced emplacements will give troops within them a cover saving throw of 4+.

When Do Models Count as in Cover?

Once again, common sense is your best guide in working out whether models are actually in cover or not, and most of the time it should be pretty obvious if they are. Some situations are a bit more complex and the following conventions will help you to decide if a model is behind cover.

- 1 Models immediately behind cover such as rocks or walls are protected from shooters that are on the other side.
- 2 The corner of a building, vehicle, or large rock counts as cover to any models placed on the edge so that they are partly obscured. The models lean out just far enough to see and use their weapons, posing as small a target to the enemy as possible. This is very useful when you are fighting amongst buildings or ruins.
- 3 Models at windows or doors always count as being behind cover from models outside.

- 4 Models in craters, trenches or pits always count as being in cover and protected from models outside. The interior of large craters is pock-marked with smaller holes, etc, so that even a model in the middle of it counts as in cover from shots outside.

Units Partially in Cover

Sometimes a unit will only be partially in cover (ie some of the models are in or behind cover and some of them are out in the open). In this situation the owning player has to remove casualties from amongst the models in the open first until there are none left – they are the more obvious targets and will suffer commensurately.

COVER SUMMARY TABLE

<i>Example Cover Type</i>	<i>Cover Saving Throw</i>
Bushes	
High grass	6+
Crop fields	6+
Fences	
Railings	
Crates/Barrels	
Pipes/Logs	
Rocks/Rubble	5+
Wreckage/Ruins	5+
Walls/Buildings	
Vehicles/Wrecks	
Woods/Jungles	
Trenches	
Gun pit emplacements	
Bunkers	4+
Fortified buildings	4+

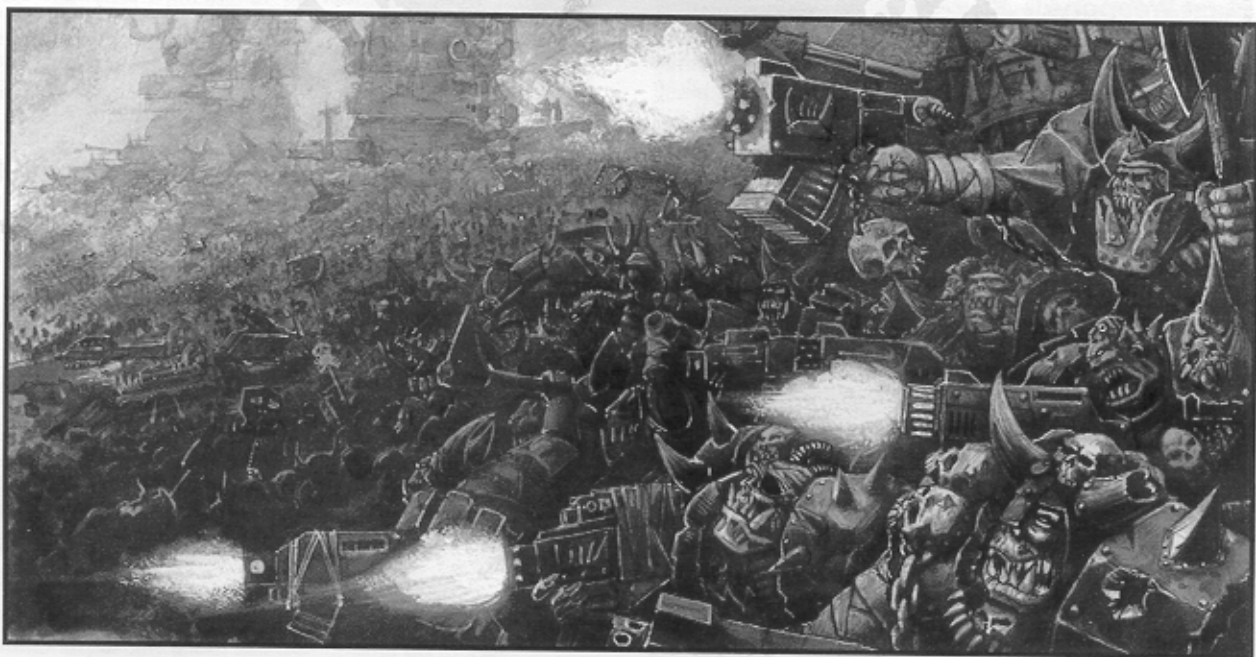

WEAPONS

The technology of the 41st millennium has spawned innumerable weapons of destruction, ranging from the simple but efficient laspistol to the barely controllable energies of the plasma cannon. In this section we'll describe how special rules and characteristics reflect the differences between different weapons.

TYPE

Different weapons have unique characteristics when fired. Some guns rattle off a burst of shots enabling them to hit multiple targets, others may fire a blast of energy or shell that explodes on impact and can kill several things at once. These qualities are represented by a weapon's **type**. The different weapon types are: blast, flame, rapid fire, pistol, heavy, barrage and linked.

In Warhammer 40,000 weapons that affect an area are represented by a template. There are three templates: a long tear drop shaped template (flame template), a circular 3" template (Blast marker) and a circular 5" template (Ordnance marker). When the weapon is fired place the relevant template on the tabletop and any models fully or partially covered by it are potential casualties. All weapons that use a template have the word 'Template' instead of a number for their range.

Multiple Shots

Some weapons like storm bolters and multi lasers fire multiple shots. Where this is the case the number of shots a weapon can fire is noted after its type. For example a multi laser can fire three shots in each shooting phase so its type is noted as *Heavy 3*.

Blast Weapons

Blast weapons fire shells, missiles or energy bolts that explode on impact, potentially injuring several victims with shock waves and shrapnel. When you fire a blast weapon roll to hit as normal. If the shot misses it has no effect. If it hits place the Blast marker over the target unit to see which models are affected.



Models partially covered are hit on a D6 roll of 4 or more, models completely covered are hit automatically. The defending player has to remove any casualties inflicted from the models directly beneath the Blast marker.

Unscrupulous players may be tempted to use blast weapons to pick off leaders and heavy weapons in an unrealistic fashion. To prevent this the following rule applies. The owner of the target unit can move an incoming Blast marker onto a different part of the target unit providing that:

- The Blast marker covers the same number of models (or more) in the same unit.
- The new target is within the firer's range and line of sight.

Flame Weapons

Indiscriminate short-ranged weapons such as flame throwers affect a broad, cone-shaped area represented by a template. Instead of rolling to hit place the template so its narrow end is touching the base of the firing model and the rest covers the maximum number of models in the target unit.

Models fully or partially under the template are hit automatically. As template weapons bathe the area in burning fuel, acidic spray, etc., all cover is ignored when resolving hits. As for blast weapons, casualties inflicted by flame weapons must be taken from amongst the models actually covered by the template.

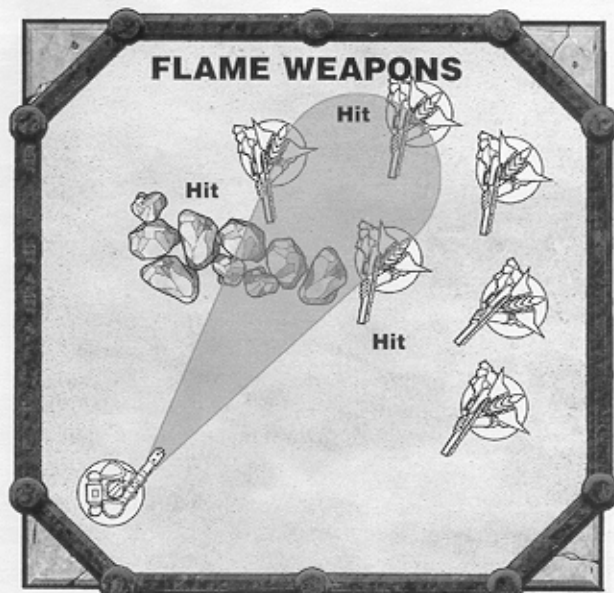

FIRING A RAPID FIRE WEAPON

Stationary



Up to 12" = 2 shots

Moving



Up to 12" = 1 shot

Up to maximum range = 1 shot

If a model using a rapid fire weapon remains stationary it can fire two shots up to 12" but only one shot up to the weapon's maximum range. If the model moves then it can only fire one shot up to a range of 12"

FIRING AN ASSAULT WEAPON

Stationary



Maximum range of weapon

Moving



Maximum range of weapon

An assault weapon can always shoot the number of times indicated and up to its maximum range regardless of whether the model using it moved or not.

FIRING A HEAVY WEAPON

Stationary



Shoots up to maximum range of weapon

Moving



May not shoot

If a model with a heavy weapon remains stationary it can fire up to the maximum range of the weapon. If the model moved, however, it cannot shoot that turn.

Rapid Fire Weapons

Self-loading weapons that carry a reasonably large amount of ammunition are called rapid fire weapons. These are very common and usually come in the form of sub-machine guns or assault rifles. They can lay down a withering hail of fire, especially at close range if the firer is stationary and concentrates on aiming and firing. Their high rate of fire also means they can be fired effectively 'from the hip' when a squad is advancing, spraying shots into the enemy whenever they present themselves.

If a unit armed with rapid fire weapons moves, each model can shoot once at targets up to 12" away.

If a unit armed with rapid fire weapons remains stationary each model can shoot twice at targets up to 12" away or once at targets over 12" away.

Pistol Weapons

Pistol weapons are similar to rapid fire weapons but are light enough to be carried and fired one-handed. As they are lighter they often have a less powerful charge that limits their range. On the plus side they allow a trooper to fight in close combat with a combination of pistol and sword, axe or other close combat weapon.

If a model armed with a pistol moves it can shoot once at targets up to 12" away.

If a model armed with a pistol weapon remains stationary it can shoot twice at targets up to 12".

Heavy Weapons

Heavy weapons are heavy man-portable weapons such as heavy bolters or lighter weapons which need to be recharged between each shot, carefully set up or whatever. If a unit moves then it cannot shoot heavy weapons, they either move or shoot, but not both (remember that even if the model armed with the heavy weapon doesn't move it still can't fire if other members of its unit move). When shooting heavy weapons always fire the number of times indicated regardless of range in the same way as assault weapons. They are very good for laying down long range supporting fire or knocking out tanks, strongpoints, etc.



Victory needs no explanation, defeat allows none.

Assault Weapons

Assault weapons are used to support units as they charge forward into the attack. They either fire so rapidly or are so indiscriminate that you don't have to do much more than point and shoot. For example a flamer is a weapon which fires a fan-shaped gout of burning fuel so it's just as accurate whether you are moving and firing or not. These weapons shoot the number of times indicated – whether you move or not and regardless of range. This means they are very good for assaulting things... hence the name!

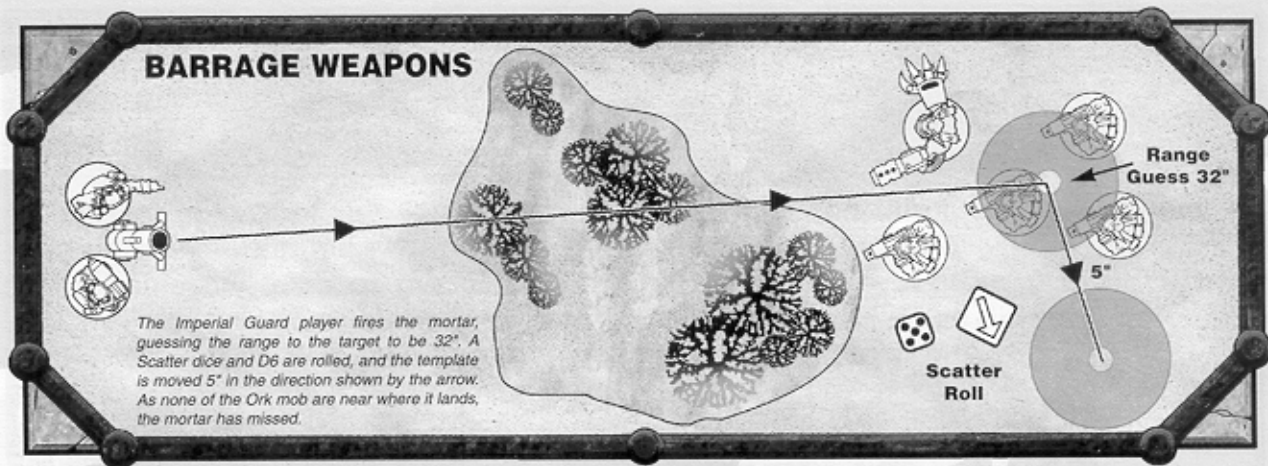

Barrage Weapons

Certain blast weapons launch their shells high up into the air so that they plunge down a distance away, passing over any intervening obstacles en route. Weapons like these fire by guessing the range to the target. They are shown by their maximum range being preceded by a G (Guess), eg G48". When you fire barrage weapons you have to state the target unit and then guess the range to it in inches from the firing unit. Intervening obstacles and terrain do not block the line of fire for these weapons so you don't need a line of sight to the target in order to shoot at it.

Place the Blast marker for the weapon at the distance guessed and then see if it landed on target by rolling the Scatter dice and a D6 together. If you roll a HIT symbol the shot lands at the range guessed. If an arrow symbol is rolled the marker is shifted in the direction indicated by the arrow a number of inches equal to the roll on the D6. Calculate hits on enemy models and remove casualties as for blast weapons (ie from beneath the Blast markers).

If a unit has more than one barrage weapon they will all be fired together in a salvo, with one Blast marker landing for each weapon firing. Guess the range and roll for any potential scatter with the first shot as above, this is the 'ranging shot' for the salvo and all the other shots will land nearby. Once the first marker is in place roll a Scatter dice for each other Blast marker in the salvo. If an arrow is rolled place the marker in the direction indicated so that its edge is touching the edge of the marker placed for the ranging shot. If a hit is rolled the firing player may place the marker so that its edge is touching the edge of any of the Blast markers in the salvo which have already landed.

Linked Weapons

Weapons are sometimes linked to fire together in order to increase their chances of scoring a hit through the crude expedient of blasting more shots at the target. To represent the fusillade of fire laid down by a linked weapon you may re-roll the dice to hit if it misses. However if the second roll is also a miss you can't re-roll the dice again.

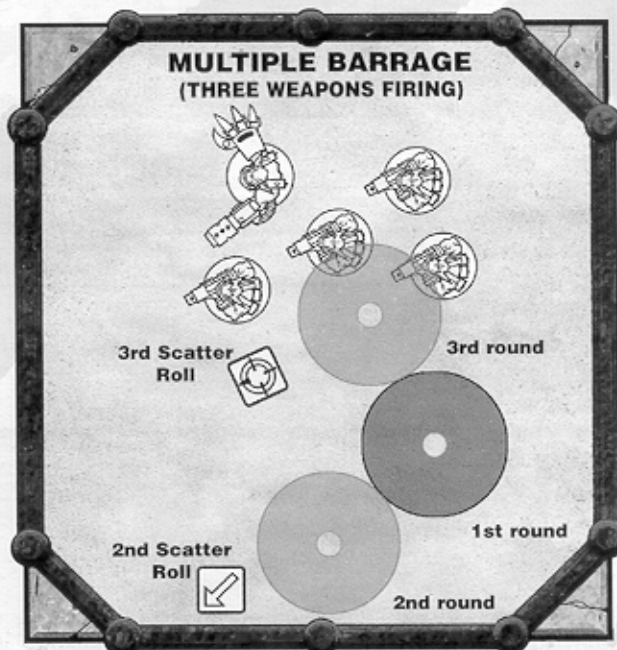

"Incoming!" – Barrage Pinning

Barrages are sudden and shocking affairs – shells scream down out of nowhere and troopers throw themselves flat as the ground erupts into fountains of dirt and lethal shrapnel.

Units that suffer casualties from a barrage must pass a Leadership test to avoid being pinned down. If the unit fails it may not move, shoot or assault in its following turn. At the end of its following turn the unit recovers and may act normally again.

A unit pinned down does not have to take a Morale test if it sustains 25% casualties from enemy fire, the fact it is pinned overrides the Morale test.

If assaulted by the enemy the pinned unit will fight normally, ignoring the falling shells under the more pressing circumstances of battle.

WEAPONS TABLE

NAME	RANGE	Str.	AP	TYPE
Bolt Pistol	12"	4	5	Pistol
Boltgun	24"	4	5	Rapid fire
Storm Bolter	24"	4	5	Assault 2
Heavy Bolter	36"	5	4	Heavy 3
Autopistol	12"	3	–	Pistol
Autogun	24"	3	–	Rapid fire
Shotgun	12"	3	–	Assault 2
Assault Cannon	24"	6	4	Heavy 3 ¹
Autocannon	48"	7	4	Heavy 2
Laspistol	12"	3	–	Pistol
Lasgun	24"	3	–	Rapid fire
Multilaser	36"	6	6	Heavy 3
Lascannon	48"	9	2	Heavy 1
Flamer	Template	4	5	Assault 1
Heavy Flamer	Template	5	4	Assault 1
Meltagun	12"	8	1	Assault 1 ²
Multi-melta	24"	8	1	Heavy 1 ²
Sniper Rifle	36"	X	6	Heavy 1 ³
Rippa Gun	12"	4	6	Assault 2
Missile Launcher (Krak)	48"	8	3	Heavy 1 ⁴
Missile Launcher (Frag)	48"	4	6	Heavy 1 Blast ⁴
Gmd.Launcher (Krak)	24"	6	4	Assault 1 ⁴
Gmd. Launcher (Frag)	24"	3	6	Assault 1 Blast ⁴
Mortar	Guess 48"	4	6	Heavy 1 Blast
Plasma Pistol	12"	7	2	Pistol ⁵
Plasma Gun	24"	7	2	Rapid fire ⁵
Plasma Cannon	36"	7	2	Heavy 1 Blast ⁵

NAME	RANGE	Str.	AP	TYPE
<i>Ork Weapons</i>				
Gretchin Blasta	12"	3	–	Assault 1
Slugga	12"	4	6	Pistol
Shoota	24"	4	6	Rapid fire
Big Shoota	36"	5	5	Assault 3
Rokkit Launcha	24"	8	3	Assault 1
<i>Eldar Weapons</i>				
Shuriken Pistol	12"	4	5	Pistol
Shuriken Catapult	12"	4	5	Assault 2
Shuriken Cannon	24"	6	5	Heavy 3
Death Spinner	12"	6	–	Rapid fire
Fusion Gun	12"	6	2	Assault 1 ⁶
Lasblaster	24"	3	6	Assault 1
Reaper Launcher	48"	5	3	Heavy 2
Scatter Laser	36"	6	6	Heavy D6 ⁷
D-cannon	Guess 24"	10	2	Heavy 1 Blast
<i>Dark Eldar Weapons</i>				
Splinter Pistol	12"	3	5	Pistol
Splinter Rifle	24"	3	5	Rapid fire
Splinter Cannon	24"	4	5	Assault 4
Shredder	12"	6	–	Assault 1 Blast
<i>Tyranid Weapons</i>				
Venom Cannon	36"	8	4	Assault 2
Barbed Strangler	24"	4	5	Assault 5 ⁸ Blast
Warp Blast	24"	6	2	Blast
Death Spitter	18"	6	5	Assault 1 Blast
Devourer	12"	4	5	Assault 4
Fleshborer	12"	4	–	Assault 1

NOTES

¹ **Jam Rule.** If a triple 1 is rolled on the To Hit dice for the assault cannon it jams and is destroyed. The assault cannon is specifically designed for Terminators – it is not an ordinary man-portable weapon.

² **Meltaguns and Multi-meltas.** These are devastating short ranged 'heat rays'. Melta weapons roll an extra D6 to penetrate vehicles at half range or under (12" for multi-meltas or 6" for meltaguns). See the Vehicle rules later for more details on armour penetration.

³ **Sniper Rifle.** Always hits on 2+ and its Strength always equals the Toughness of the target (so it wounds on a 4+ regardless of Toughness). Units suffering casualties from sniper rifles must test to avoid pinning as for a barrage. A sniper rifle only has an armour penetration of D6 against a vehicle.

⁴ **Missile Launcher or Grenade Launcher.** These can fire either frag or krak rounds, choose which to shoot before rolling to hit.

⁵ **Plasma Weapons Get Hot!** If you roll a 1 to hit the weapon has overheated and injured the model firing it. Make an armour save for the model otherwise it will suffer a wound (yes, really!). If the model is killed the plasma weapon is lost as well. Plasma weapons on vehicles are not affected by overheating.

⁶ **Fusion Guns.** These weapons work like meltaguns against vehicles, gaining an extra D6 penetration at half range or under.

⁷ **Scatter Laser.** An improved Eldar version of the multi-laser that shoots D6 times rather than 3. Roll each time it fires.

Thought begets Heresy; Heresy begets Retribution.

WEAPONS OF THE 41st MILLENNIUM

BOLTGUNS



Boltgun (Model 482)

The boltgun or bolter is the codex issue armament of the Emperor's Space Marines. They are superb, if temperamental, devices of destruction which need the finest materials and skilled artisans to construct. Master-crafted bolters are treasured artefacts and some have been maintained by Space Marine Chapters for hundreds or even thousands of years. All bolters require regular maintenance rituals and cleaning to keep them fully operational.

Bolters fire self-propelled armour-piercing mass-reactive explosive missiles called bolts. These detonate a split second after penetrating a target, blasting it apart from within. The force of the explosion can destroy even armoured vehicles. Bolters are normally set for rapid fire, each pull of the trigger firing a burst of three or four bolts in quick succession.

Being caught amidst the thunderclap explosions of bolter fire is a frightening experience, ideally suiting the standard shock/assault role of Space Marines. For covert fighting special low-velocity solid core bolts are used.

Different patterns of Bolter: Ultima Pattern, Crusade Pattern, Heresy Pattern, Filienostos Pattern, Astartes Umbra Pattern.

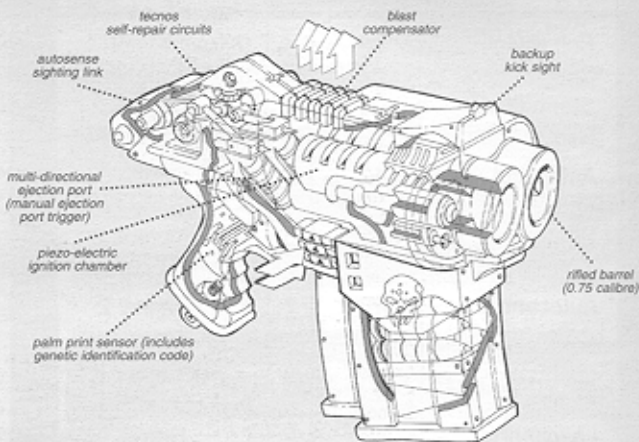

Storm Bolter

Magazine Types: Sickie (standard magazine 20-30 rounds staggered), Drum (carries 40-60 rounds but tends to cause ammo jams), Straight (carries 12-20 rounds, easier to load), Duplus X (two magazines strapped/welded/taped together), Bolt pistol clip (6-10 rounds).



Bolt Pistol

Standard Bolt

Outer casing, propellant base, main charge, mass reactive detonator cap, depleted deuterium core, diamond tip, spin stabilised 0.75 calibre.



Hellfire Round

Core and tip replaced with mutagenic acid vial.



Stalker Silenced Shell

Propellant base and main charge replaced by gas cartridges, detonator cap replaced by solidified mercury slug.



Inferno bolt

Deuterium core replaced with oxy-phosphur gel.



Metal Storm Frag Shell

Mass reactive cap replaced by proximity detector, diamond tip and deuterium core replaced with increased charge and fragmentation casing.



Kraken Pattern Penetrator Round

Deuterium core replaced by solid adamantite core and heavier main charge.

PLASMA WEAPONS



Plasma Pistol

The ancient technology required to construct plasma weapons is only known by an inner circle of Adeptus Mechanicus Artisans and Munitions Adepts. Few are constructed today, and each is individually crafted and blessed by the Machine God before being allowed into service. Most Space Marine Chapters continue to maintain a few plasma weapons in their armoury, revering them as ancient and irreplaceable weapons from a former age.

Ammunition for a plasma gun consists of a photonic hydrogen cell or flask. Two of these vessels are usually screwed into place inside the weapon before battle. These two flasks feed a fusion core, where the hydrogen becomes highly energised and converts into a plasma state. The plasma is held in the core by a powerful magnetic field, then allowed to escape along a linear magnetic accelerator, speeding the plasma 'bolt' towards its target. The molten gas explodes on impact, generating the destructive heat of a small sun before dissipating.

Plasma fuel flasks, usually good for approximately ten shots, are not reusable after firing. Reloading a plasma gun is time consuming as both flasks have to be unscrewed and new ones carefully screwed into position.

Plasma weapons use similar technology to that used in plasma reactors and drives. The colossal energies generated are constrained within a powerful magnetic field. It is the magnetic containment field which is so difficult to replicate and maintain. Field failure can result in the plasma becoming unstable and the weapon overheating in a catastrophic meltdown. Emergency venting for escaping super-heated steam is a vital feature of plasma weapons.

In the 41st millennium it is an honoured, but dangerous task, to be a plasma gunner.

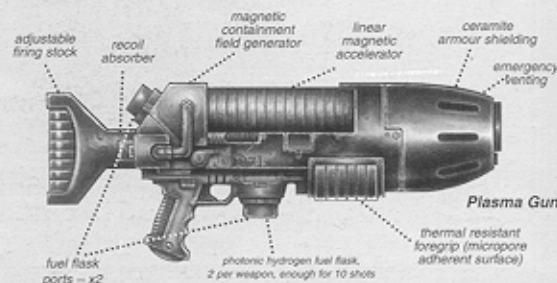

Plasma Gun

Chapter Approved: Scal 363b
Imperial Class: Delta 465a

LAS WEAPONS



Las Pistol

By far the most numerous weapons in the Imperial armoury are laser or las weapons. Cheap to manufacture and easy to use and maintain las weapons are issued in vast numbers to the Imperial Guard and are readily available on most Imperial worlds. Laser weapons emit a beam of focused light. The short duration high energy beam produces such a rapid temperature change on the target's surface that it vapourises in a small explosion. Lasguns are driven by a fast discharge generator, which comprises most of a lasgun's mechanism and stores energy for each shot. Actual beam energy is regulated to prevent overpowering, making the lasgun very reliable.

Lasguns fire with a searing flash of light and a distinctive snap or crack. In lasguns and pistols each pull of the trigger fires a single laser shot. Lasguns can maintain a high rate of fire in the hands of a trained Guardsman with a good firing drill.

Power packs feed the discharge generator. Rechargeable power packs or batteries, usually with a highly efficient liquid metal core, vary between small internal packs used in lasguns and pistols to massive power packs the size of crates that power lascannons and multi-lasers. Powerpack capacity varies immensely but most are good for about 40 shots. In contrast to maintain maximum power output efficiency lascannon powerpacks need replacing after every shot. Overpowered laser packs, like the so-called 'Hotshot', provide weapons with a more potent charge but give fewer shots. They cannot easily be recharged after use and the extra stress on the barrel requires much more maintenance.

There are many different designs of lasgun and pistol, and most worlds produce their own versions, made of locally available materials, be it ceramite alloys, thermo-set plastics or even wood fittings. Many lasguns and pistols include solar converters for recharging powerpacks and various optic sights as standard, such as iron sights, mono-sights or infra-red sights. Designs vary from derring-type pistols to highly ornate hand-crafted duelling pistols to the more robust service weapons issued to the Imperial Guard.

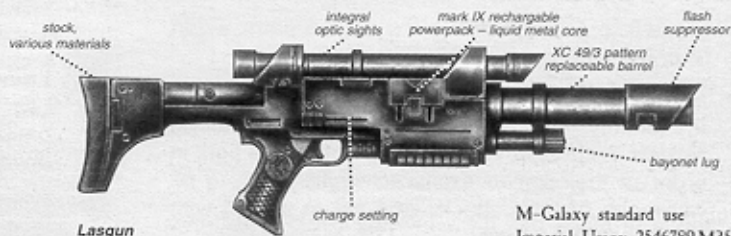

MELTA WEAPONS

Melta weapons, sometimes called fusion guns, melters or cookers, fire a sub-molecular thermal blast over a short distance, causing massive molecular breakdown and turning the target into molten slag and steaming vapour in a matter of seconds.

Most melta guns use highly pressurised pyrum-petrol gases, charged to produce a fearsome blast. Melta guns use a two part injection system to force the gas into a sub molecular state, which will vaporize just about any target. This results in an awesomely powerful blast at short range, with the heat dissipating rapidly at longer ranges. The two part reaction makes melta weapons slow to fire but the devastating results make them a popular support weapon on the battlefield, especially useful in an anti-tank role, or when attacking enemy strongpoints. Many commanders prefer melta weapons over the less reliable plasma gun.

A melta gun makes very little noise when fired except for the high pitched hiss of vaporizing moisture which becomes a roaring blast as the target detonates.

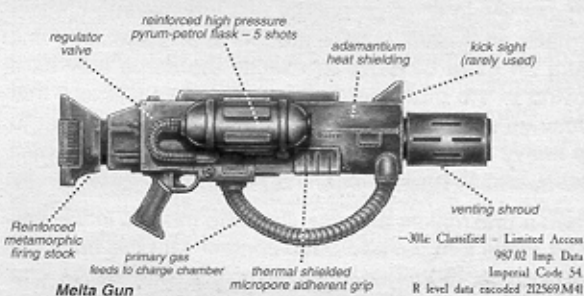

THE ASSAULT CANNON

The assault cannon is a six-barrelled, self-loading autocannon. Driven by an internal motor the assault cannon has a very high rate of fire. It is carried by Space Marine Terminators and is used in confined areas and tunnel fighting for clearing rooms and corridors. Assault cannons are forged of a tempered ceramite alloy, resistant to the intense heat generated by the fast spinning motor and the wear caused by the thousands of shells fired. Despite this barrels are regarded as disposable and are usually replaced after every mission. Motor and barrel failure are common problems with the assault cannon, resulting in the weapon being prone to jamming.

Assault cannons fire a fixed cartridge round, a dense metallic core covered in a non-metallic composite sheath with a diamantine tip. This gives good armour penetration and stable flight ballistics at short ranges and keeps the rounds small, so that more ammunition can be carried.

Assault cannons include gyrostabilisation to help the gunner keep the weapon on target and recoil compensators are built into the Terminator suit.

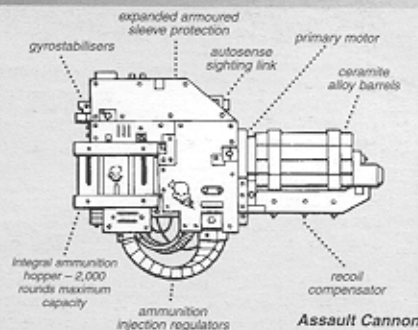

The techs of the Adeptus Mechanicus make imperfect use of the ancient knowledge that they zealously preserve. Though the principles and practice of sub-atomic circuitry and crystal-stacked molecular power cells are far beyond the comprehension of these techno-mystics, they are none the less able to utilise and maintain the machinery of ancient days and therefore make use of technology far in advance of other races.

ASSAULT

While firepower may be enough to drive an enemy back from open ground or lightly held positions, shifting a determined foe from a fortified bunker or ruined settlement will need sterner measures. In an assault troops storm forward, screaming their battlecries, eager to strike at their foe with knives, claws, gun butts or anything else in a desperate close combat.

Assault can be summarised in 5 steps:

1 **Move Into Assault.** Move any of your units, within 6" of the enemy, into contact.

P **Fight Close Combat.** Troops in base contact with the enemy, or within 2", fight in close combat. Models in cover strike first, then both sides fight in order of their Initiative characteristics. Roll to hit with each of their attacks and roll to wound with any attacks which hit.

3 **Determine Assault Results.** Total up wounds inflicted. The side which inflicted the most wounds is the winner.

4 **Loser Checks Morale.** The loser has to pass a Leadership test or fall back 2D6". If the loser passes the test both sides move more models into combat and fight again in the next assault phase.

5 **Winners Advance Or Consolidate.** If the loser falls back the winner can advance 2D6" or consolidate by moving his models 3" in any direction.

1. MOVING INTO AN ASSAULT

In his own assault phase a player can charge any unit that is within 6" of an enemy unit forward into contact to make an assault. All the models in an assaulting unit make an extra 6" move in exactly the same way as if moving in the movement phase. A unit of warriors that remained stationary in the movement phase in order to fire heavy and/or rapid fire weapons cannot assault as it is assumed to be spending the whole turn shooting.

When a unit makes an assault **all** the models in the unit **must** move into base-to-base contact with the enemy if they can do so. The closest models move first and towards the enemy by the most direct route. Once units are fighting at close quarters like this they are said to be 'engaged in close combat'.

Terrain Effects

Models assaulting into, out of or through difficult terrain will be slowed down in the same manner as models moving through it in the movement phase. Roll two D6 and pick the highest to see how far they can move.

WHO CAN FIGHT

Close combat is a swirling mêlée of fighters leaping forward, spinning, hacking and slashing at one another. As well as fighting hand-to-hand, warriors will be firing at point blank range at any target that presents itself.

The player who is making the assault is obliged to get as many of his models into close combat as he can – there is no holding back! Models must be moved forward against enemy models not already in base contact where possible. All models who are within 2" of an enemy model will take part in the fighting as well, not just those in base contact. If there are any models at the back of a unit who cannot make it into contact with the enemy move them in as close as possible.

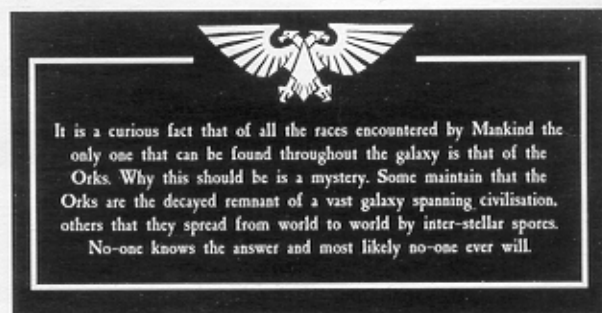
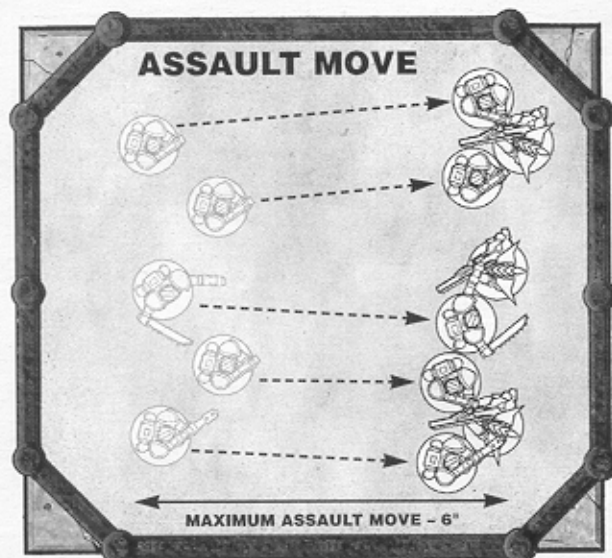

2. FIGHTING A CLOSE COMBAT

How good creatures are in close combat depends almost entirely on their physical characteristics, in other words how fast, strong, tough and ferocious they are. Armour remains useful for warding off blows and shots but weaponry becomes a secondary consideration – the best gun in the galaxy won't help if your opponent is bashing your brains out with a rock!

In close combat both players' models fight. How many blows are struck and who strikes first are discussed below. The rules are written assuming that there is only a single close combat occurring in the turn, of course there may be several separate assaults being fought simultaneously in different parts of the battlefield. If this is the case the player whose turn it is can choose what order to fight the combats in.

WHO STRIKES FIRST

Troops who are defending cover have a massive advantage in an assault. They can fire from their hiding place at their approaching enemies and then smite them down as they struggle to get to grips with their hidden foe. It's all in the reflexes when it comes to combat in the open: slow lumbering opponents can be quickly dispatched by a faster and more agile foe. Unfortunately, lumbering opponents such as Orks are tough enough to be able to withstand a vicious pummeling and still come back for more.

In close combat models defending in or behind cover strike first. Resolve all their attacks and remove any casualties before moving on to the rest of the models. Fighting for the remainder is resolved according to the Initiative value of the models. Models with the highest Initiative attack first, then the next highest and so on.

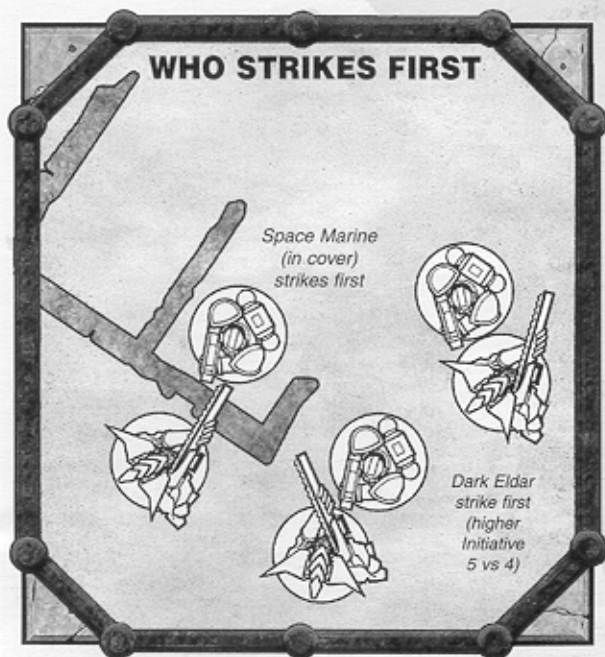

Work your way down the Initiative scores in each separate combat until everyone has fought (assuming they haven't already been killed by a model in cover or with a higher Initiative). If both sides have models with the same Initiative, attacks are made simultaneously.

Cover

Models in or behind cover always fight first in close combat regardless of Initiative. This represents the advantage of cover – their attacks include not only close fighting but also shots against the enemy as they charge in. Apart from this cover does not affect hits or anything else in an assault. After the first round of close combat fighting is assumed to have swept into the cover so it gives no further advantage to models in it.

ATTACKS

Attacks in close combat work like shots in shooting – each attack that hits has a chance to wound, the wounded model gets a chance to save, and if it fails is (generally) removed as a casualty. Each model base-to-base with an enemy model strikes with the number of Attacks (A) on his characteristics profile. In addition the following bonus attacks apply.

+1 Two Weapons. Models in base-to-base contact with a pistol/close combat weapon in each hand have an extra +1 Attack. Models with more than two weapons gain no additional benefit – you only get one extra Attack regardless of whether you have two or more close combat weapons.

+1 Charged. Models in base-to-base contact who launched the close assault that turn (ie charged) get +1 Attack on their normal profile for that turn only.

Models not touching an enemy, but within 2" of one, may make one Attack regardless of their profile, armament or whether they charged.

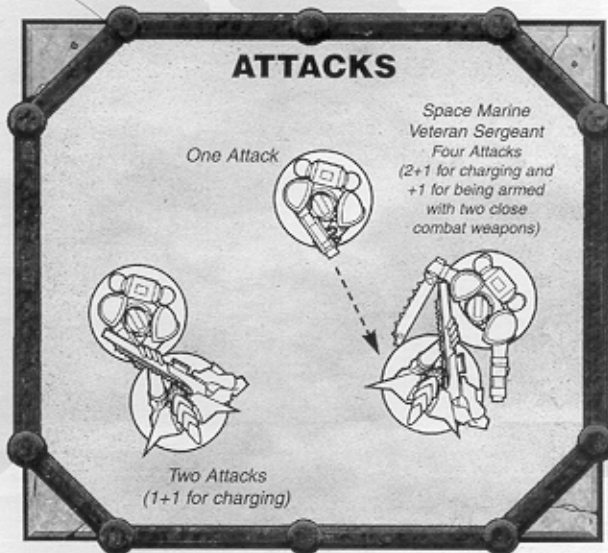

ROLLING TO HIT

To determine whether hits are scored roll a D6 for each Attack a model has. The dice roll needed to score a hit on your enemy depends on the relative Weapon Skills (WS) of the attacker and his foe. Compare the Weapon Skill of the attacker with the Weapon Skill of his opponent and consult the following chart to find the minimum score needed on a D6 to hit.

Where large numbers of combatants have the same characteristics it is often convenient to roll for their attacks together.

EXAMPLE: A unit of five Space Marines fighting five Eldar would roll five D6s for their attacks. If they were charging they would roll ten D6s (1 Attack +1 each for charging).

Since all of the Space Marines need the same roll to hit and the same roll to wound you may as well roll them together and then allow the Eldar player to allocate the hits as detailed below. This approach saves time and speeds up the game when you've got several big close combats going on at once.

It is better to die for the Emperor
than to live for yourself.

Allocating Attacks

A model can fight if its base is touching the base of an enemy model or if it is within 2" of an enemy model. Ordinarily we simply assume that the warrior is contributing his shots and blows to the swirling combat going on. This means we don't have to worry about whether individual models strike their respective opponents in base contact.

However, if a model is in base-to-base contact with opponents with varying Weapon Skill and Toughness characteristics it will be necessary to allocate attacks to different targets before rolling to hit. This is because the dice scores needed to hit and to wound them will be different. The model's attacks can be divided up as the player wishes, as long as he makes it clear before rolling to hit.



TO HIT CHART



		OPPONENT'S WEAPON SKILL									
		1	2	3	4	5	6	7	8	9	10
ATTACKER'S WEAPON SKILL	1	4+	4+	5+	5+	5+	5+	5+	5+	5+	5+
	2	3+	4+	4+	4+	5+	5+	5+	5+	5+	5+
	3	3+	3+	4+	4+	4+	4+	5+	5+	5+	5+
	4	3+	3+	3+	4+	4+	4+	4+	4+	5+	5+
	5	3+	3+	3+	3+	4+	4+	4+	4+	4+	4+
	6	3+	3+	3+	3+	3+	4+	4+	4+	4+	4+
	7	3+	3+	3+	3+	3+	3+	4+	4+	4+	4+
	8	3+	3+	3+	3+	3+	3+	3+	4+	4+	4+
	9	3+	3+	3+	3+	3+	3+	3+	3+	4+	4+
	10	3+	3+	3+	3+	3+	3+	3+	3+	3+	4+

Thought For The Day: If a job's worth doing it's worth dying for!



DAMAGE CHART



TOUGHNESS

STRENGTH

	1	2	3	4	5	6	7	8	9	10
1	4+	5+	6+	6+	N	N	N	N	N	N
2	3+	4+	5+	6+	6+	N	N	N	N	N
3	2+	3+	4+	5+	6+	6+	N	N	N	N
4	2+	2+	3+	4+	5+	6+	6+	N	N	N
5	2+	2+	2+	3+	4+	5+	6+	6+	N	N
6	2+	2+	2+	2+	3+	4+	5+	6+	6+	N
7	2+	2+	2+	2+	2+	3+	4+	5+	6+	6+
8	2+	2+	2+	2+	2+	2+	3+	4+	5+	6+
9	2+	2+	2+	2+	2+	2+	2+	3+	4+	5+
10	2+	2+	2+	2+	2+	2+	2+	2+	3+	4+

ROLLING TO WOUND

Not all of the attacks that do hit will harm your enemy. They may be deflected by equipment, parried at the last moment or merely inflict a graze or flesh wound. Once you have scored a hit with an Attack you must roll again to see if you score a Wound and incapacitate your foe.

The procedure is the same as for shooting. Consult the chart above, cross referencing the attacker's Strength characteristic (S) with the defender's Toughness (T). The chart indicates the minimum D6 roll required to inflict a Wound.

EXAMPLE: A Space Marine (Strength 4) hits a Dark Eldar (Toughness 3). Referring to the Damage chart above we find that the Space Marine requires a 3 or more on a D6 to wound.

Identify your target. Concentrate your fire on it to the exclusion of all else. When it is destroyed choose another target. That is the way to secure victory.

Tacticus Imperium

Official! The graves of warriors who have given their lives for the Emperor now outnumber the stars themselves.

What Strength To Use

In almost all cases, when rolling to wound in close combat use the Strength on the attacker's profile, regardless of what gun they are using. Some (but not all) close combat weapons give attackers a Strength bonus; these are detailed later.

ARMOUR SAVES

Models struck and wounded in close combat can attempt an armour save to avoid becoming casualties. Models usually get to save regardless of the attacker's Strength but some especially monstrous creatures and powerful close combat weapons will punch straight through armour.

Note that cover provides no extra protection in close combat as it does against shooting. Remember that invulnerable models are allowed to make armour saving throws even where none would normally be allowed.

SPECIAL CLOSE COMBAT ATTACKS

Even though high powered lasers and plasma weapons scour the battlefields of the 41st millennium close combat remains commonplace – sieges, city fighting, boarding actions and tunnel warfare are noted more for the ferocity of the fighting than any strategic nuances. Seasoned warriors always bear a deadly array of clubs, knives, frag grenades and bayonets for close-quarter fighting.

Assault troops will be even more fully equipped, taking pistols, swords and axes into battle with them. Most deadly of all are the power weapons that are sheathed in disruptive energy fields of crackling blue bale-fire. Power weapons splinter ceramite armour plates and melt plaststeel in the blink of an eye, smashing through even the toughest armour like paper.

Specialised weaponry can give troops a real edge in close combat. Some of the most common close combat weapons and special attacks are listed below. In all cases models can only use their special attacks if they are in base-to-base contact with the enemy, otherwise they attack normally. Note that models with special close combat attacks can always choose not to use them and attack normally instead, if you're wondering why you might want to do that read the Power Fist entry below!

Power Fist or Claw

A power fist or claw is a powered, armoured gauntlet surrounded by an energy field that disrupts solid matter. It is an awesome weapon most commonly seen fitted to Space Marine Terminator armour.

A power fist or claw doubles the user's Strength up to a maximum of 10 and ignores armour saves. The only drawback is that a power fist is slow and cumbersome to use, so a model armed with a power fist or claw always strikes last in close combat regardless of relative Initiative and whether or not they are defending cover or using frag grenades to assault into cover, etc. If models on both sides are armed with power fists they strike simultaneously.

Power Weapons

A power weapon (typically a sword or axe, but more rarely a glaive, halberd or mace) is sheathed in the lethal haze of a disruptive energy field. When a blow is struck a crackling blast of energy tears at the target, eating through armour, flesh and bone with ease.

A model armed with a power weapon ignores armour saves.

Close Combat Weapons (chainswords/swords/axes/pistols etc)

There is a bewildering array of close combat weapons ranging from simple clubs and axes to hand flamers and chainswords. These weapons confer no bonus to the strength or hitting power of combatants. However, as a model with a weapon in each hand gains an additional attack against an enemy in base-to-base contact, swords and pistols (or similar hand weapons) remain a useful combination for hand-to-hand fighting.

Frag Grenades

Fragmentation grenades can be thrown at opponents in cover to force them to keep their heads down during a charge. The lethal storm of shrapnel from exploding frag grenades will drive opponents further into cover for a few precious moments while the attackers close in.

Troops armed with frag grenades always fight simultaneously against troops in cover. Initiative values are not used, both sides roll to hit and wound at the same time before making armour saves and removing casualties.

Monstrous Creatures

A monstrous creature is so huge and powerful that its attacks make a mockery of armour, foes are not so much wounded as hideously mangled and crushed.

A monstrous model (Carnifex, Greater Daemon etc.) ignores armour saves.

REMOVING CASUALTIES

Casualties are removed by the player suffering them with the following restrictions. Casualties must be removed from the models in base contact with the enemy first, then from models that are fighting near the enemy (ie within 2"). Casualties are only carried over onto models more than 2" from an enemy where all other models have been slain. If an attack has been allocated against a specific enemy, then the wounds are **only** applied against that enemy model.

If a model has his opponent taken as a casualty before he has an opportunity to attack he may still attack

another enemy model as if in base-to-base contact (remember the mêlée is a mobile swirling conflict not static as our models are, the attacker could have the opportunity to leap forward over the casualty to attack another opponent behind him). You may find it convenient to place the casualty on its side next to the model as a reminder that he fights in the combat with his full number of attacks.

As mentioned previously it's generally assumed that players will roll all attacks of the same Initiative value together to speed up close combats. However, if both players agree you can resolve attacks model by model. In this case simply remove casualties as they occur.



Look to your battle gear
and it will protect you

We guard it with our lives

Your armour is your
Soul, and your Soul's
dedication its armour

The soul of a warrior
is the shield of humanity

Honour the
craft of death

Only the Emperor is
higher in our devotion

Honour the battle
gear of the Dead

We ask only to serve

Part of the *Warrior's*
Catechism of Worship

3. DETERMINE ASSAULT RESULTS

Assaults are usually very decisive, one side or the other quickly gains the upper hand and forces back their foe. Numbers and leadership can keep a side in the fight but the casualties each side inflicts is the most telling factor.

To decide who has won the combat, total up the number of wounds inflicted by each side. The side that causes the most is the winner, the other side is the loser and may be forced back if they fail a Leadership check. Note that wounds which have been negated by armour saves do not count, nor do wounds in excess of a model's Wounds characteristic, only wounds actually inflicted.

Enemy Destroyed!

If one side destroys the enemy it wins automatically – even if it sustained more casualties. The victors can consolidate or advance as normal. If an advance is chosen it must be made towards the enemy.

Tiebreaker (Moral High Ground)

If both sides score the same number of wounds roll a dice each to see who gains the upper hand, the highest score wins. If both scores are the same neither side wins and the combat really is drawn as detailed later.

4. LOSER CHECKS MORALE

Units who lose a close combat must test their morale to hold their ground. If they fail they must abandon the fight and fall back 2D6". If they pass the unit holds its ground and fights on – basically the combat is drawn and no further account is made of the unit's defeat.

Morale checks and Falling Back are covered in more detail in the Morale section of the rules.

The blood of martyrs
is the seed of the Imperium.

5. WINNERS ADVANCING & CONSOLIDATING

Where a side has won and their enemies fall back, the victors can choose to either **advance** or **consolidate** their position. If they won on a tie-breaker they may **only** consolidate. They may make this decision **after** the enemy has fallen back (ie you can see how far they run!).

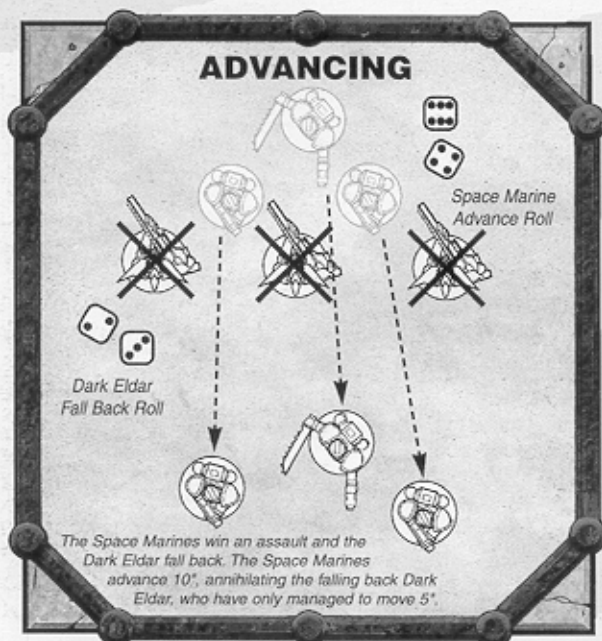

ADVANCE

The victors move 2D6" forward directly after their withdrawing enemy. If they roll greater than their enemies' Fall Back score they catch and destroy them. This represents the victors shooting the enemy down as they retreat, scattering them beyond recovery, and generally jumping up and down on their corpses.

Units advancing into, out of or through difficult terrain only move **half** the distance rolled on 2D6.

If a unit is pursuing a foe who falls back off the board the pursuing unit will stop when it reaches the table edge.



Serve the Emperor today,
tomorrow you may be dead.

Sweeping Advance

Advancing units must move the full distance rolled, in the same direction towards and through the enemy if they outpace them. If this brings them into contact with fresh enemy they move directly into base contact, effectively assaulting the enemy and beginning another close combat.

No further combat is fought during the turn that the advance is made; combat is, instead, fought in the following turn. The advancing unit is considered to have launched an assault that turn, and receives the normal +1 Attack bonus.

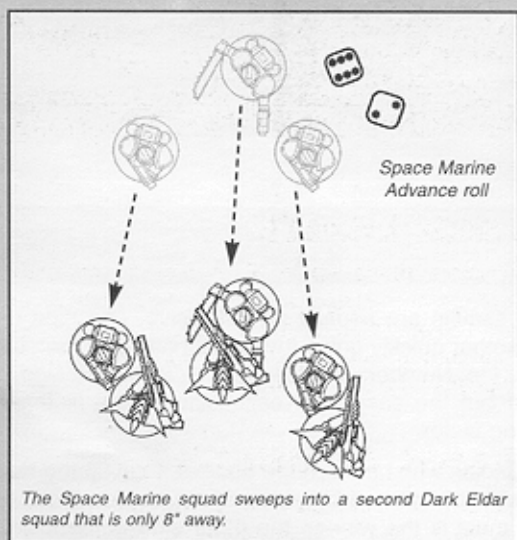

Partial Contact

Occasionally a sweeping advance or similar circumstance will lead to a situation where attackers engage some models in an enemy unit but not all of them. Models in base contact can not move away in their turn, but any unengaged models may move around as normal providing they maintain unit coherency. At the start of the next assault phase unengaged models may move in to help out their comrades as long as the unit did not remain stationary to fire with heavy or rapid fire weapons.



There is no time
for Peace.

—
No respite

—
No forgiveness

—
There is only
WAR!

CONSOLIDATE

The victors move up to 3" in any direction to take advantage of cover/ground to consolidate their position. This is the only action a winner can take if they won the combat through a tie-breaker roll off. Units consolidating their position ignore difficult terrain.

DRAWN COMBATS

In a drawn combat individual models remain where they are if they're touching base-to-base. Otherwise, fighting units from both sides **must** move all models up to 6" forward, ignoring difficult terrain, into base contact with enemies, or as close as they can where this is not possible. They must move against unengaged models in preference to models already in base contact. If both sides have unengaged models to move in roll a D6 each, highest score moves in first.

MULTIPLE COMBATS

If several units are fighting in the same combat, total up the number of Wounds inflicted by each side to determine who is the winner. All the units on the losing side have to check their morale. Individual winning units can only advance or consolidate if all of the units opposing them fall back.



Shooting in Close combat

Models in base-to-base contact may not fire weapons in the shooting phase. Their attentions are completely engaged by the swirling mêlée. Likewise, while especially twisted and soulless commanders may wish their warriors to fire indiscriminately into close combats in the hopes of hitting the enemy, this is not permitted. The events in a close combat move too quickly and the warriors themselves will be understandably hesitant about firing on their comrades (they may end up in the same straits soon enough after all), so just forget it, alright!

However, an exception to this rule is during a *Sweeping Advance*. In this case the advancing unit will be exposed to enemy fire as it moves forward – and will make a very tempting target for the unit on the receiving end of their advance. Therefore units making a *Sweeping Advance* can be fired at before the next assault phase is fought, even if they have moved into base-to-base contact with another unit. Range is measured to where the advancing unit has reached and even models they have moved into base-to-base contact with may fire.

MORALE

The Imperial Guardsmen advanced cautiously down the steep slope. Ahead, the rebel positions were being heavily suppressed by a couple of Leman Russ battle tanks stationed at the top of the hill. A high pitched whistling sound, followed by a hollow roar, rolled across the valley and a jet of flame erupted from the centre of the nearest Leman Russ. The second tank revved its engines and lumbered down the opposite slope in search of this new threat leaving the Guardsmen on their own. No sooner had the battle tank moved away than the rebels retook their firing positions and opened fire on the unsupported Guardsmen. Lasfire scorched the hillside and pierced the bodies of the unprotected loyalists. As one the remainder of the squad dropped to their bellies and returned fire. The rebels, however, were in excellent positions with heavy weapon emplacements trained upon the hill.

As lasgun fire sizzled around him, Sergeant Drecta could see that the situation was hopeless. His squad was stuck out on a limb, he had to get his men out of range of the withering hail of fire.

"Back up the hill men. Regroup at the top."

Even as he gave the order, his men were scrambling back up the hill, each stopping every few yards to snap off a couple of covering shots for their comrades. Speedily and efficiently, Drecta's squad withdrew back out of range and waited for support.

It's a lucky commander who can rely on his troops to perform fearlessly all of the time. In the chaos and confusion of battle troops can easily become demoralised, disorientated or outright terrified by the violence unleashed against them. To represent this element of the unknown your units of troops have to check to see if their morale remains good under certain circumstances. As you will have already gathered Morale tests can occur at a number of different times, so a unit in particularly dire straits may be forced to take several Morale checks in a single turn.

LEADERSHIP TESTS

Units use their Leadership characteristic for taking Morale checks. This represents the grit, determination, élan or (sometimes) plain stupidity of warriors in action. Morale checks are taken by rolling 2D6 and comparing the total score to the unit's Leadership value. If the score is equal to or under the unit's Leadership value the test is passed, if it is higher the test is failed.

Leadership Modifiers

Circumstances can make Morale checks harder for a unit to pass. For example, a unit that has already suffered heavy casualties will be more inclined to give way than a unit that is untouched. This is represented by Leadership modifiers for Morale checks and these reduce the unit's Leadership value by -1, -2 or sometimes even more.

TAKING MORALE CHECKS

Only infantry have to take Morale checks – tanks, Dreadnoughts and other vehicles never have to. Particularly monstrous or fanatical units may be immune to the effects of morale, but where this is the case any special rules are included in their description. Note that some units automatically pass Morale checks, while others automatically pass all Leadership tests. This is a subtle but important difference. For example, units immune to Morale checks will still have to test for barrage pinning.

Infantry units normally check Morale in three situations:

- If they take 25% or more casualties in the shooting phase. Test at the end of the phase.
- If defeated in close combat in the assault phase. Test once combat results are established.
- If a tank breaks through their line. Test once the vehicle has moved.

A) ENEMY FIRE

Any unit taking 25% or more casualties of its current strength from shooting during a single shooting phase must check against its Leadership not to **fall back**.

-1 If the unit is below 50% starting strength.

EXAMPLE: A unit of five troops suffers two casualties (reducing it to 60% of its starting strength) so it takes a Morale check. Next turn the unit, now three strong, suffers another casualty (reducing it to 40% of starting strength) so it takes another Morale check, this time at -1 Leadership for being below 50% of starting strength.

Facts are chains that bind perception and fetter truth.
For a man can remake the world if he has
a dream and no facts to cloud his mind.

B) LOSING AN ASSAULT

Units that lose a close combat (ie they suffer more wounds than they inflict) must test against their Leadership to hold their ground. If they fail, the losers must fall back. The Leadership test is modified by the following factors:

- 1 If the unit is below 50% starting strength.
- 1 If the losing side is outnumbered by its opponents*.
- 2 If the losing side is outnumbered 2:1 or more.*
- 3 If the losing side is outnumbered 3:1 or more.*
- 4 If the losing side is outnumbered 4:1 or more.*

* Only apply the highest of these modifiers.

EXAMPLE: A Dark Eldar warrior squad has lost an assault. They would normally require an 8 or less to pass the Leadership test, but are below half strength (-1) and outnumbered 2:1 (-2), which means they require 8-3=5 or less. They roll a 6 and fail.

C) TANK SHOCK

Units that are driven at by an enemy tank may well wisely decide it's time to abandon their position and fall back. If a tank reaches a unit's position then the unit must check against its Leadership to see whether or not it falls back. For a fuller explanation of how Tank Shock works see the Vehicle rules later on.

- 1 If the unit is below 50% starting strength.

All On Your Own (Last Man Standing)

Sometimes a unit will be almost entirely wiped out, with only a single member left. Such lone individuals must take a Leadership test at the start of each of their turns. If they pass they are filled with heroic fervour and continue to fight on single-handedly. If they fail they suffer an outbreak of common sense and begin to fall back.

FALL BACK!

Fall back is a fighting withdrawal, not an out-and-out rout. Sometimes a fighting retreat in the face of overwhelming odds is the only option left. A withdrawal can give troops the chance to retire to a stronger position to mount a fresh attack or hold off the enemy.

As a unit falls back it moves directly to the player's table edge, or to the base line where the unit deployed/entered the table if it came on at a different place. We've specified this in the scenarios in the Battles Book but if you make up your own scenarios be sure you know where your units fall back to. If possible the unit must remain coherent, with gaps of no more than 2" between models as they fall back.

Troops fall back 2D6" each turn until they regroup. Particularly fast units fall back further than this but where this happens it will be noted in the special rules for them.

A unit that falls back must move within a corridor which lies between its most extended models as shown in the diagram – but individual models can move within this corridor as you wish. If a unit is spread out such that its models are more than 2" apart the models must be moved back into coherency as the unit moves.

If the unit moves into, out of or through difficult terrain the distance rolled on the dice that it falls back is halved. Troops will divert around impassable terrain, but must move in such a way as to get back to their base line by the shortest route.

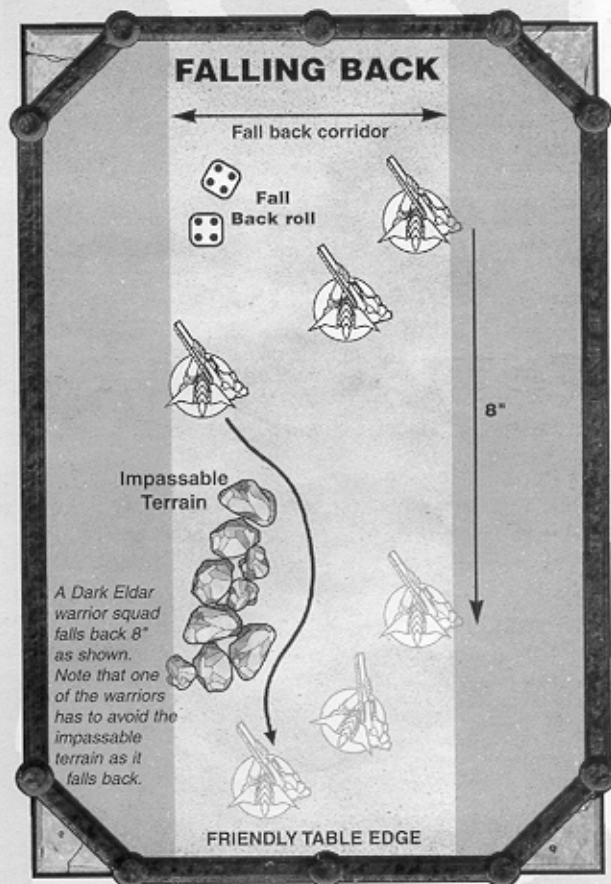

"Wherever and whenever they appear they leave only destruction in their wake; they are the Lords of Death, Bringers of War, the Dark Angels."

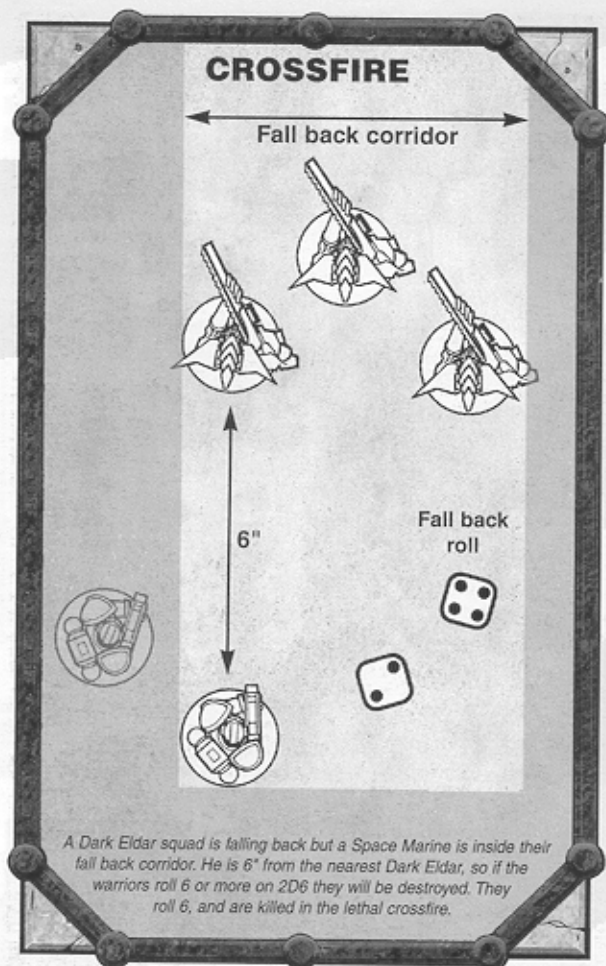

FIRING WHILE FALLING BACK

Troops who are falling back may continue to shoot, but as they are moving they may not fire heavy weapons, or rapid fire weapons at anything more than 12" away. They also cannot launch an assault.

Assaulted While Falling Back

A unit which is assaulted by the enemy whilst falling back must check to regroup immediately (see Regrouping below). No modifiers apply to the check in this case, and even units which would not normally be allowed to regroup are allowed to make the check – the situation is sufficiently life or death threatening for the usual regrouping restrictions to be ignored. If successful the unit is regrouped and will fight the close combat normally. If it fails to regroup the unit is destroyed.

THE CROSSFIRE RULE

Units forced to withdraw through enemy units will be caught in a deadly crossfire and destroyed or irrevocably scattered. If a unit is withdrawing towards the enemy measure the distance to the nearest enemy model within the fall back 'corridor' before rolling to see how far the unit falls back. If the distance rolled takes the unit up to or past the enemy model the unit is destroyed.

Note that only models from units that have **not** fought in close combat that turn can be used for crossfire purposes.



Men united in the purpose of the Emperor are blessed in his sight and shall live forever in his memory.

Ecclesiarch Deacis



REGROUPING

A unit falling back can attempt to regroup by taking a Leadership test at the **start** of its next move phase so long as:

- 1 *There is at least 50% of its original strength remaining.*
- 2 *There are no enemy within 6".*
- 3 *The unit is coherent (see page 43).*

If you fail (or the unit *cannot* regroup because of the restrictions given above) the unit must continue to fall back, and is moved a further 2D6". Remember that even units that are falling back can still shoot. However they are still subject to the Crossfire rule.

If the unit successfully makes its Leadership test, it will then be able to regroup. It cannot move any further during that movement phase, except that models are allowed to be move up to 3" to rearrange their firing line or take up positions in cover. Difficult terrain does not reduce this 3" move at all.

Once a unit has regrouped it fights as normal. It can, for example, shoot (counting as moving that turn) or mount an assault that turn if it gets the chance.

REGROUPING IN COVER

If a unit moves into cover that lies within its fall back corridor, it may attempt to regroup again as it does so. Effectively this is a second chance to regroup. A unit may only attempt to regroup in cover **once** per movement phase as long as none of the normal restrictions apply. Make the test once the whole unit is in cover. If passed it regroups and halts. If it fails it must complete its fall back.

Regrouping After an Assault

A unit that has been defeated in an assault cannot regroup by moving through cover during the same turn.

LAST CHANCE

Once a unit reaches the table edge it has one more chance to regroup, if it fails it is removed and may not return. Note that there is no need for individual models in the unit to move 'off' the table, once any reach the edge it is last chance time! Finish the move for all the models in the unit, stopping any who would finish off the table edge, and then attempt to regroup, as long as none of the usual restrictions apply. If the unit regroups it stops at the table edge. If it fails it is removed.

CHARACTERS

The screams of the wounded were everywhere. Sergeant Wulf prayed fervently to the Emperor as he crouched behind the blasted stump of a Guara tree. The brightly patterned jungle foliage around him was torn to shreds by another Eldar volley, making him want to dig down deeper, become a rat and disappear into a hole.

A voice rang out "GET UP! STAND AND FIGHT!" Wulf half-rose almost by instinct and glanced to his left. There stood Commissar Borg, snapping off shots with his pistol as if on a firing range, back straight, jaw jutting in a determined fashion. The Commissar showed no hint of doubt or fear despite the razor-edged death which sang through the trees all around him. Borg unlimbered his chainsword in an almost leisurely fashion.

"COME ON MEN! WITH ME!" Wulf hesitated for just a second. Then the sight of the Commissar, his face pitted and scarred by a hundred battles, gripped the Sergeant's heart. He'd never let them down before. With a final gasped prayer, Wulf rose from his hiding place and levelled his lasgun at the armoured Eldar who were stalking the woods. The squad followed and the advance began again.

Nearly every race or power throws up exceptional individuals who stand out above the normal herd. Veteran warriors, brilliant officers, inspired prophets, ferocious war-leaders and monstrous daemons can take to the battlefield and make a difference to combat. They inspire others to greater feats of heroism (or fiendish bravery as the case may be) and are usually quicker, stronger and more powerful in combat. In Warhammer 40,000 these powerful individuals are called *characters* and there are certain special rules that apply to them.

Characters In Battle

Characters fight as part of an army in one of two ways. Ordinary characters are fielded as part of other units from the start of the game. They are effectively another trooper in the unit with enhanced characteristics and usually a superior Leadership value.

Independent characters are represented by individual models, which fight as units in their own right. However, as we shall see, one of the most useful abilities of independent characters is to join other units in battle, so that they can move in to bolster the battleline where the fighting is fiercest.

Only in death docs duty end.

Character Movement

Characters follow the normal movement rules for troops of their type be it infantry, cavalry or bikes. Independent characters can move through difficult terrain more quickly than ordinary troops. This means you are allowed to re-roll any dice throws for independent characters moving in difficult terrain.

PSYCHIC POWERS

Some of the army lists include characters who are allowed to use psychic powers. These characters are often referred to as psykers. Psychic powers vary from race to race, so the effect of each power and when it may be used is included in the special rules for the psyker in the army list. The rules below tell you how to find out if the psyker can use his powers, and what can happen to him if things go wrong...

It requires intense concentration and inner calm for a psyker to use his power, which is not always easy to attain in the midst of a firefight! In order to use one of his powers the psyker must make a Psychic test by rolling equal to or under his Leadership on 2D6. If he fails the psyker's concentration has been broken and he can not use the power that turn. If he passes the power may be used as described in the special rules for the psyker in his army list. A psyker may not attempt to use more than one power per turn.

Psychic attacks are subject to the usual Shooting rules, so the psyker must be able to see the target, and all attacks must be directed against a single target unit, etc. This is because even telepathic psykers find that in the heat of combat it is hard to pinpoint the mind of an opponent with any clarity; generally they all blur and merge in a confusing swirl.

PERILS OF THE WARP

In order to use their psychic powers a psyker must draw deeply upon the power of the warp. This is a risky and very dangerous thing to do, for the warp is inhabited by hostile creatures that can attack an unwary psyker during the few moments that he draws upon the warp to use his powers.

To represent the dangers of the warp, if a psyker rolls a 2 or a 12 when he takes a Leadership test in order to use a psychic power, he is attacked! The psyker suffers 1 automatic hit with a Strength equal to the roll of a D6, no saves allowed – a warp creature has tried to fry the psyker's brain! Note that on a roll of a 2 the psychic power works, even though the psyker has been attacked or killed.

CHARACTERS IN UNITS

Characters who are part of a unit must obey all the usual coherency rules, meaning that they must remain within 2" of a member of their unit.

Independent characters are allowed to move freely around the battlefield and can temporarily join other units if desired. While an independent character is part of a unit he must obey the usual coherency rules until he leaves the unit as detailed below.

Independent Characters Joining and Leaving Units

In order to join a unit an independent character simply has to move within the 2" coherency distance of the unit during his movement phase. Note that if an independent character joins a unit which has special abilities such as infiltrators, jump pack troops, cavalry etc., he does not gain any of the abilities of the unit.

An independent character may leave a unit during the movement phase by moving out of coherency distance with it.

An independent character may only join or leave a unit during the movement phase – once assaults are launched it is too late to join in or duck out!

SHOOTING AT AND BY CHARACTERS

Independent characters can only be chosen as targets if they are more than 6" away from any other viable target unit or if they are the closest target at short range (up to 12"). Otherwise you can't shoot at them.

Characters shoot just like ordinary troopers, although in many cases they will have superior Ballistic Skills or exotic weaponry that sets them apart. Where this is the case either roll for them separately or use different coloured dice to differentiate their shooting.



CHARACTERS IN ASSAULTS

All characters in assaults fight just like normal troopers, though their characteristics are usually better. If a unit including an independent character charges into close combat the character must charge in too.

An independent character on their own can charge into close combat if they are within 6" of the enemy in the assault phase (12" if the character is mounted as cavalry).

Allocating Attacks

A character fighting in close combat can always choose to allocate his attacks against enemy models in base-to-base contact, unlike ordinary troopers who may only do so if their opponents have different Weapon Skills and Strengths. A character's attacks can be divided up as the player wishes, as long as he makes it clear before rolling to hit.

If a player chooses to allocate attacks in this way the character can **only** inflict casualties on the models in base-to-base contact with him. It can be imagined that the character is deliberately looking to cut down those before him instead of rampaging through the press of fighting troops, dealing death wherever possible.

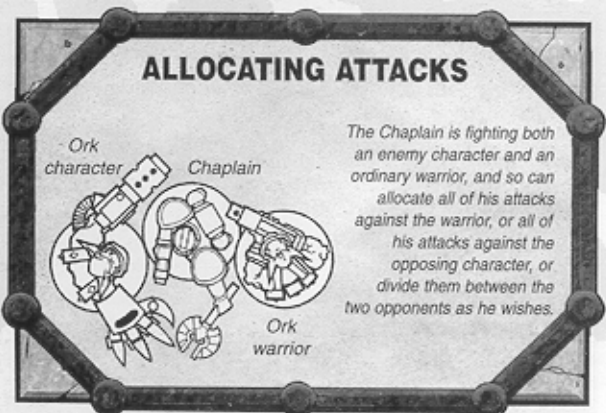



CHARACTERS AS LEADERS

One advantage of a character being part of a unit is that any Leadership tests the unit takes are then made using the character's Leadership value. If an independent character is part of a unit that falls back he may not leave the unit until it regroups. Independent characters never have to take 'all on your own' tests.

Special Characters

In the army lists, later in this book, you'll find characters you can field as part of your army. As with squads of troops you can choose for your army, the character's profile tells you how tough he is and what weapons and armour he can have. It is left to you to name your heroes, and follow their illustrious careers across bloody battlefields.

Nonetheless the 41st millennium is filled with famous characters renowned as legendary heroes or infamous villains. These individuals are called *special characters* and can be found in the Codex army books and in White Dwarf magazine.

Special characters are highly skilled and dangerous opponents who have special traits or skills that make them particularly valuable to an army.

For example, Lord Commander Solar Macharius is without doubt the finest Imperial Guard commander who ever lived, his armies conquered nearly a thousand worlds in under seven years. An army led by him can expect great benefits in strategy and tactics if little direct help in fighting. On the other hand Khârn the Betrayer, an exalted champion of the Dark Gods, is a mad butcher and slaughterer of men with no thought for anything other than personal combat (which it must be granted, he excels at).

Special characters represent unique individuals, past and present, that many players like to use in their games to give background or history to their army. However, these powerful characters can dominate certain types of game, especially the smaller battles. It is general practice that special characters can only be used if both players agree to do so before the battle.

VEHICLES

This section of the rules describes how vehicles of all shapes and sizes move and fight. As mentioned earlier, vehicle rules are quite different to those for infantry in order to show their unique strengths and weaknesses. Vehicles can move swiftly and bring a tremendous arsenal of weapons to bear as infantry fire patters harmlessly off their armoured hide. However, determined infantry squads with the right weapons can use dense terrain to outmanoeuvre lumbering vehicles and can easily knock them out unless the vehicles have their own infantry to guard them.

VEHICLE CHARACTERISTICS

Vehicles have characteristics that define how powerful they are in a similar way that troops do. However as vehicles do not fight in the same way as creatures of flesh and blood their characteristics are different. Vehicle characteristics are as follows.

Ballistic Skill. Vehicles have a BS value just like troops and it represents the accuracy of the crew as they blast away at their enemy with the vehicle's weapons.

	Type	Front Armour	Side Armour	Rear Armour	BS
Leman Russ	Tank	14	12	10	3

Armour Value. The Armour Value of a vehicle tells you how hard it is to damage. Weapon hits against vehicles must defeat their Armour Value in order to inflict damage. Vehicles generally have different Armour Values on their front, sides and rear.

Type. Vehicles come in all sorts of different types, some are faster than others while some are able to fly or walk instead of driving along on wheels or tracks. Any special traits a vehicle has are described by its type. The different types are Fast, Tank, Open-Topped, Skimmer and Walker.

Every human life is a spark in the darkness. It flares for a moment, catches the eye, and is gone forever. A retinal after-image that fades and is obscured forever by newer, brighter lights.



WAR MACHINES OF THE 41st MILLENNIUM



OPEN-TOPPED VEHICLES

Some vehicles are not fully enclosed, but expose their crews to a hostile universe. There are many reasons for this: It may be to give reconnaissance units a good field of vision, to make embarking and disembarking easier, or it may simply be impractical to enclose the crew. In the case of Imperial Guard artillery vehicles such as the Basilisk for example, the crew require plenty of space to load and fire the enormous Earthshaker cannon. This aside, it is mostly smaller, lighter vehicles that are open topped, such as Ork buggies and trukks.

While crews and embarked troops on open-topped vehicles have more freedom of movement and much better arcs of vision, the lack of an enclosed cabin inevitably means that they and their vehicle are more vulnerable to incoming fire.

FAST VEHICLES

There is a role in any army for high-speed vehicles. These are usually smaller vehicles which will often be used to reconnoitre ahead of an army or rapidly deploy heavy weapons systems or infantry squads to critical parts of the battlefield. Some races such as the Eldar use fast vehicles almost exclusively (jetbikes, Vypers, etc.) enabling them to carry out the lightning raids and deep strikes for which they are rightly feared. Most of the fastest vehicles on the battlefield are skimmers, such as the Space Marine

land speeder, as these avoid terrain problems which slow down conventional craft, however a few wheeled or tracked vehicles are also capable of high speeds, mostly due to either ultra-light weight or extremely powerful engines.

SKIMMERS

While most vehicles travel across the ground upon wheels, tracks or legs, some advanced machines are fitted with anti-gravitic drives that enable them to swoop and hover a few meters above the battlefield. This is not true flight, but rather gravitic repulsion in a limited plane. The Space Marine land speeder is the only Imperial vehicle with this capability as the helio-prismic engines are very difficult and expensive to produce, limiting their issue to only the Emperor's elite troops. The land speeder is a highly manoeuvrable, light reconnaissance and fast strike craft. It is capable of high speeds and can execute very tight turns but is limited in its vertical movement by a climb/dive incidence of no more than 35° from the horizontal due to inverse flux anomalies which arise beyond this point.

The only race to have truly mastered skimmer technology is the ancient and highly advanced Eldar. They build nearly all of their vehicles around sophisticated tri-polar phased crystal engines. These are manufactured in all sizes from the small and super-light units in jetbikes to the huge engines that power super-heavy grav-tanks such as the Scorpion. The Falcon is perhaps the best example of Eldar skimmer technology. It is a large tank that is not only capable of low altitude flight but can also climb and dive almost vertically. Orks on the other hand are not sufficiently advanced to fully comprehend anti-grav technology.



Sometimes the good must perish
so that the rest survive.
The lot of courage is to be
sacrificed upon the altar of battle.

TANKS

Tanks are a common sight on the battlefields of the 41st millennium. For an infantryman, a tank is an awesome sight as it rolls across the battlefield. It will not only be immune to most of the weaponry carried by his squad, but it is able to bring to bear enough firepower to utterly eradicate him and his unit.

Most races field some kind of heavily armed and armoured vehicle, whether it be the huge and lumbering Leman Russ battle tanks of the Imperial Guard or the sleek and sophisticated grav vehicles of the Eldar. Tanks are often fitted for multi-role capability and this will commonly include troop transportation as well as tank-hunting capability or infantry support with a deadly arsenal of weapons.

Imperial vehicles are often ancient in design, the basic plans having been rediscovered thousands of years ago, before the Emperor's Ascension. Despite the antiquity of their design, their sheer ruggedness and versatility mean that they remain a match for enemy vehicles. Alien tanks are very different machines. Eldar combat vehicles are highly advanced, not only do they float above the ground using sophisticated anti-gravity engines, they are also faster, more manoeuvrable and better armed than their Imperial counterparts. By contrast, Orks use crude contraptions that are almost as dangerous to their crews as they are to their enemies!

WALKERS

On any battlefield, there are places where conventional vehicles cannot go – built-up areas, dense forests, narrow tunnels, and so on. For this reason, many armies use vehicles that are propelled by two – or sometimes more – mechanical legs. These vehicles are usually capable of carrying as many weapon systems as a tank can on a significantly smaller and lighter chassis. They combine the armoured might of a tank with the manoeuvrability of an infantryman. In general these vehicles have a single crewman, Space Marine Dreadnoughts however are more than simply a one man vehicle. They contain the mortally wounded remains of great Space Marine heroes, becoming

Adeptus Codis Ref: 63544/b
Imperium Administratum File 74/c

Success is commemorated. Failure merely remembered.

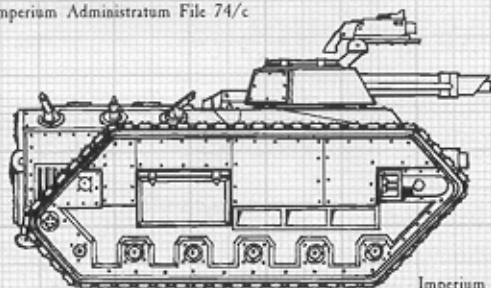

Imperium sectus 2

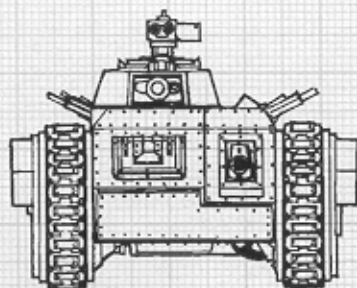

ARMAGEDDON PATTERN Mk XIII CHIMERA TROOP CARRIER

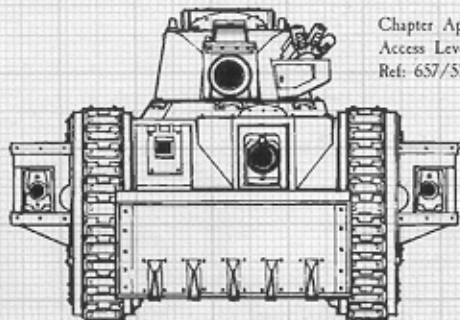
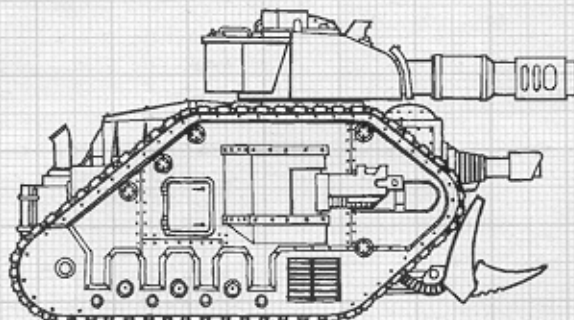

Chapter Approved
Access Level: β 2
Ref: 6S7/S14



PHAETHON PATTERN Mk XV LEMAN RUSS BATTLE TANK (Note additional dozer blade & upgraded thermic combustor power plant)

Adeptus Codis Ref: 63745/d

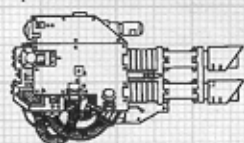

Dreadnought Lascannon
(Death Fist KZ107)

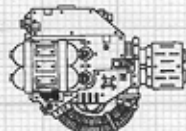

Dreadnought Multi-Melta
(Firestorm FR071)

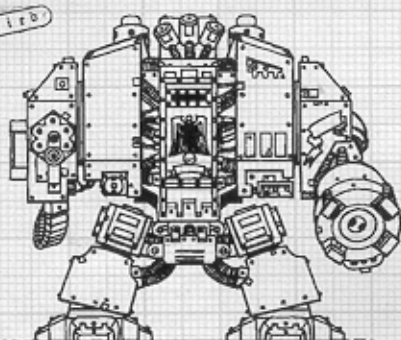

ADEPTUS ASTARTES DREADNOUGHT
(Delta 9 Massacre Assault Cannon and Death Fist Armament)

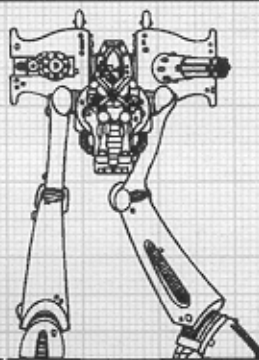

ALIEN MANUFACTURE
Attack Walker (Lammas Campaign)

mausoleum and war machine all in one. It is considered the greatest honour for a Space Marine to be incarcerated into one of these ancient machines so that they may continue to serve the Emperor. The Eldar Wraithlord on the other hand does not have any crew at all. It is 'piloted' instead by a spirit stone containing the vital essence of a dead Eldar warrior.

Because of their manoeuvrability, lighter walkers are often used as recon vehicles. The Imperial Guard Sentinel and the Eldar War Walker are both designed with this role very much in mind. Dreadnoughts on the other hand – especially those created by the Orks – tend to be used as shock assault vehicles, striding into battle alongside their infantry and spearheading assaults.

Knowledge is power, hide it well.

In the ancient past human technology reached the pinnacle of its achievement and Mankind accomplished many great wonders of stellar engineering, terraforming, and astrogenetics. Since then much of that knowledge has been forgotten or its true nature misunderstood. The greatest of all the achievements of the past are ascribed to supernatural forces and the heresies of the Dark Age of Technology. Today's guardians of knowledge dabble in arcana and mysticism whilst the secrets of the past lie ignored or reviled before them.

VEHICLE MOVEMENT

Most vehicles can move up to 12" in the movement phase. This is relatively slow, but it represents a cross-country speed rather than moving flat out. However, most vehicles will want to move even slower in order to use their weapons (see later). Most vehicles can only move in the movement phase, but some can move in both the movement phase and the assault phase just as troops can.

Vehicles can turn any number of times as they move, just like any other model. Vehicles turn by pivoting on the spot, rather than 'wheeling' round. Turns do not cost any of the vehicle's move. A vehicle may combine forward and reverse movement in the same turn providing it does not exceed its maximum move.

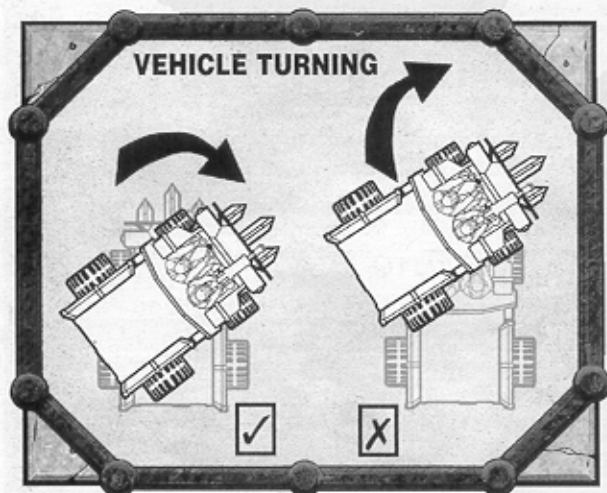

FAST VEHICLES

Some vehicles are notably fast either because of their light construction or powerful engines – or both! Fast vehicles can move up to 24" in the movement phase.

TERRAIN EFFECTS

Difficult Ground. Vehicles that move through difficult terrain are not slowed down like infantry – they will either crash through successfully or become stuck, bogged down or something similar. To represent this a vehicle that moves into difficult terrain or starts its move in difficult terrain must take a Difficult Terrain test. Do this by rolling a D6. On a roll of 1 the vehicle is immobilised for the rest of the game, on a 2-6 it can carry on moving.

Skimmers

Skimmers are vehicles that hover above ground level using anti-gravity drives, huge turbofans, supernatural energies, etc. Note that these are not full blown flying machines, they generally hover at a few metres above ground level but are capable of making a powered boost to gain height and cross obstacles. Skimmers can ignore terrain as they move but if they begin or end their move in difficult or impassable terrain they have to test to see if they are immobilised as noted for ordinary vehicles above. Immobilised skimmers are destroyed.

Walkers

Walkers are vehicles that have legs instead of tracks or wheels, the most common being huge war machines called Dreadnoughts. Walkers move like infantry so they can move up to 6" in the movement phase and then charge up to 6" in the assault phase if the enemy are within 6". Difficult terrain affects walkers just as it does infantry. Walkers moving into, out of or through difficult terrain have to roll 2D6 and use the highest result as the maximum distance they may move that turn.

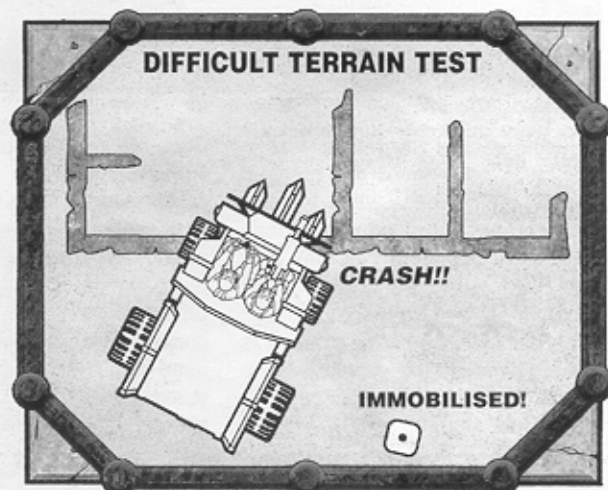

CARRYING TROOPS

Various vehicles can carry troops across the battlefield. The advantages of being able to move a squad rapidly from one area to another under the protection of armour plate is obvious. The danger is that troops will be wiped out aboard the transport if it is fired at before they disembark.

Disembarking

A unit that begins its movement phase inside a vehicle can get out either before or after the vehicle has moved. When the unit disembarks the models are deployed within 2" of the vehicle. If the vehicle has already moved then the infantry cannot move other than to deploy, and they cannot disembark if the vehicle moved more than 12". If the vehicle has not yet moved the infantry may move as normal after disembarking, the vehicle can then move off separately at any speed.

Troops onboard a vehicle may not disembark in the assault phase.

Embarking

A unit can get inside a vehicle by moving to within 2" of it. The whole unit must be within 2" of the vehicle before it gets inside. If some models are out of range their compatriots will wait until they can mount up together. If the vehicle moved before its passengers got aboard then it may not move any further in the same turn. If the vehicle has not moved beforehand then it can move up to 12" as soon as the unit is on board.

An infantry unit can embark into a vehicle in their assault phase if it consolidates and moves to within 2" of the vehicle.

DISSEMBARKING BEFORE VEHICLE MOVES

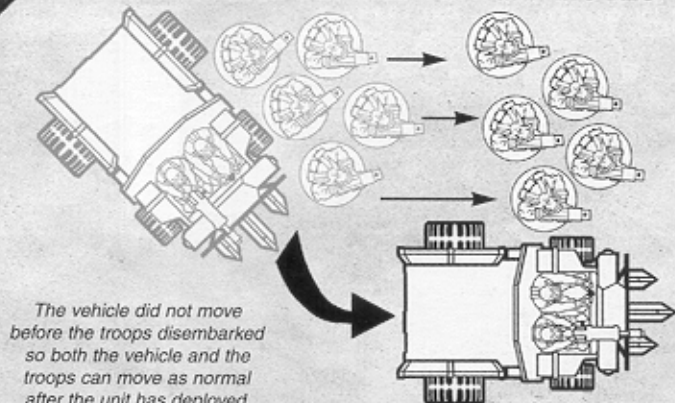

The vehicle did not move before the troops disembarked so both the vehicle and the troops can move as normal after the unit has deployed.

DISSEMBARKING AFTER VEHICLE MOVES

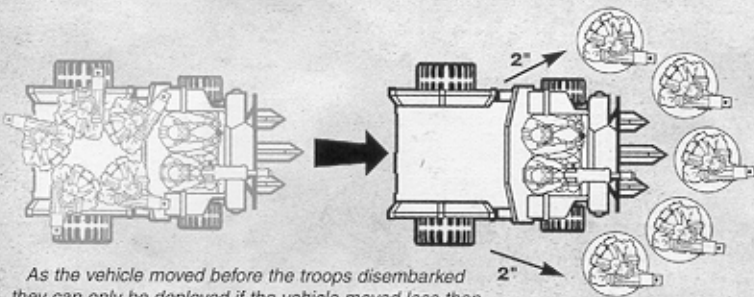

As the vehicle moved before the troops disembarked they can only be deployed if the vehicle moved less than 12". The vehicle cannot be moved any further this turn.

EMBARKING BEFORE VEHICLE MOVES

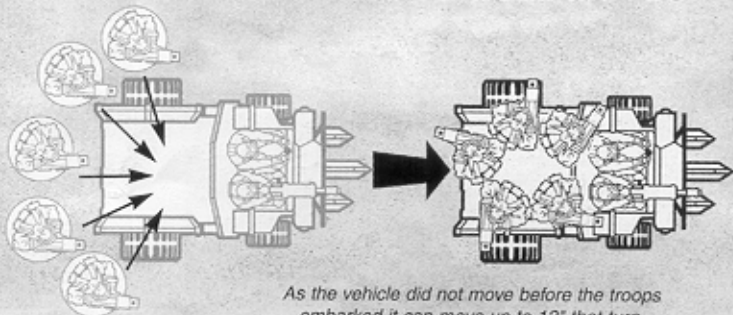

As the vehicle did not move before the troops embarked it can move up to 12" that turn.

EMBARKING AFTER VEHICLE MOVES

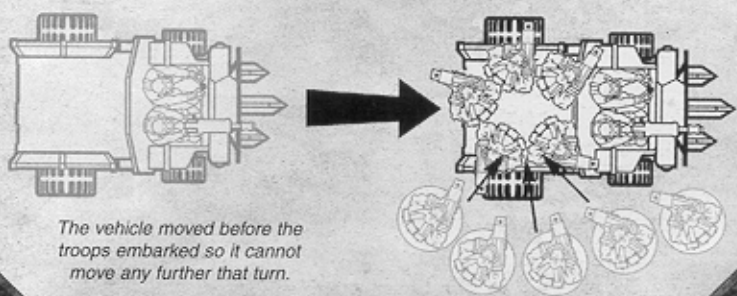

The vehicle moved before the troops embarked so it cannot move any further that turn.

**Pain is an illusion of the senses,
despair is an illusion of the mind.**

VEHICLE SHOOTING

"Diverse and many fold weaponry is of the greatest importance for the steel-clad behemoth, lest it shall be confronted by foes it cannot master. On the field of war it may battle Orks without number, against whom the burning lance of the lascannon is worthless. On another world the armoured abominations of the alien Eldar may be found, against whom the noble bolter is useless.

The commander must maintain the watchful gaze of the eagle to seek his foes through scope and slit. Once found they must be crushed with full weight of fire before seeking the next enemy, for the beast which is merely maimed may strike back still. When a suitable target is found the machine must be halted for most efficacious execution, for motion and accuracy are anathema to one another. Speed has its place, just as firepower has its own. Never forget this!"

Extract from 'Commander of Armour's First Book of Indoctrinations'

Some vehicles, particularly battle tanks, carry a hefty arsenal of weapons. When a vehicle fires it uses its own BS characteristic (representing the BS of the crew) and shoots like other units – all its weapons must fire at a single target unit. Although vehicles can fire on the move their accuracy is severely impaired and their chances of identifying targets and hitting them drops to virtually nil. In game terms this is represented by limiting the number of weapons a moving vehicle can fire compared to a stationary one.

Troops Firing From Vehicles

Troops aboard vehicles can fire from firing slits, hatches or over the sides of the fighting compartment if the vehicle is open-topped. Normally only half of the models aboard a vehicle can fire from it because of the limited number of places to fire from. However all of the models aboard an open-topped vehicle can fire.

Troops firing from a vehicle count as moving if the vehicle moves and may not fire if the vehicle moves faster than 12".

Vehicle Line of Sight

Line of sight for shooting is traced directly from the weapon mountings on the vehicle. Weapons mounted on vehicles often have a limited arc of fire and they may not fire on units that are outside their arc. Trace the actual line of fire from the weapon mounting on the vehicle to see if it will be blocked by terrain or other vehicles.

MOVING AND SHOOTING

If a vehicle does not move it can shoot all its weapons up to their maximum range. Rapid Fire weapons can shoot once up to 24", or twice up to 12", otherwise Heavy and Assault weapons shoot the number of times listed.

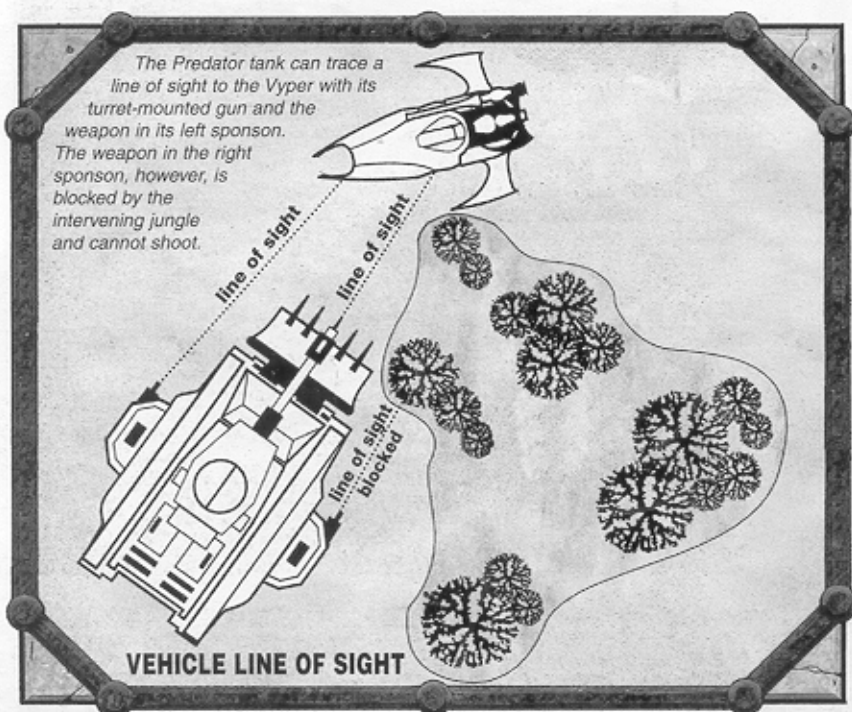

If a vehicle moves up to 6" it can shoot one weapon. This can be any weapon, including a weapon held by a driver or crew member, but it can only shoot one weapon. Rapid Fire weapons can shoot once at long range, twice at short range, otherwise Heavy and Assault weapons shoot the prerequisite number of times.

Note that the normal restrictions for infantry moving and shooting don't apply to weapons fitted to vehicles. So a heavy weapon mounted on a tank can still shoot even though the tank may have moved.

Vehicles that have moved more than 6" do not shoot at all.

Note that a twin-linked weapon counts as a single weapon for the purposes of shooting so it may be fired on the move.

Fast Vehicles

Fast vehicles manoeuvre more rapidly than ordinary tanks and other vehicles so they can fire weapons when they move faster.

Fast vehicles moving up to 6" can fire all their weapons.

Fast vehicles moving up to 12" can fire one weapon.

Fast vehicles moving more than 12" may not fire any weapons at all.

Walkers

Walkers have sophisticated weapon systems that are fully integrated with their crew so they can engage targets on the move more easily than other vehicles. This means they can always fire two weapons (one from each side/arm) regardless of whether they've moved or not. Walkers who do not move can fire all their weapons.

VEHICLE MOVING & FIRING SUMMARY

Type	Stationary	Up to 6"	Up to 12"	12"+
Normal	All weapons	1 weapon	May not fire	-
Fast	All weapons	All weapons	1 weapon	May not fire
Walker	All weapons	2 weapons	-	-

Turning to Face

Turrets can be turned to face without it counting as movement.

Vehicles can pivot on the spot as discussed above and as this is not considered to be movement it does not affect firing. Immobilised vehicles cannot pivot on the spot.

ORDNANCE

Especially large weapons are called *Ordnance*. These weapons are so huge and powerful that they cannot be physically carried but must be mounted onto a vehicle or be built into the structure of a fortress. For the most part they are used by the heavily mechanised armies of the Imperial Guard. Space Marines have little use for such slow and cumbersome equipment, but their Whirlwind rocket launcher does fall into this category – although it is the lightest weapon that counts as Ordnance.

ORDNANCE TABLE

Weapon	Range	Str.	AP	Type
Battle Cannon	72"	8	3	Ordnance 1/Blast
Demolisher	24"	10	2	Ordnance 1/Blast
Griffon Mortar	12-48 Guess	6	4	Ordnance 1/Blast
Earthshaker	120"	9	3	Ordnance 1/Blast
Whirlwind	48" Guess	5	4	Ordnance 1/Blast

Make no mistake, ordnance weapons are *huge*. So big in fact that a vehicle cannot do anything else in the same turn that it fires its ordnance. It is therefore impossible to move and shoot with ordnance in the same turn, and it is impossible to shoot any other weapons from the vehicle if you shoot the ordnance even though the vehicle is stationary.

EXAMPLE: If you shoot the Battle Cannon in a Leman Russ you cannot move and shoot the lascannon or side-armament sponsons in the same turn.



Though my guards may sleep and ships may lie at anchor, our foes know full well that big guns never tire.

ROLLING TO HIT

All ordnance weapons use the large Blast marker – which is 5" in diameter. Place the marker over the target unit you want to shoot at. Next check that the target is within range and that the weapon has a line of fire to it. If the target is out of range or out of sight the shot will automatically miss. The ordnance Blast marker may not be shifted by the defender as with ordinary Blast markers; it has a chance of scattering of its own accord as noted below.

If the target is in range and can be seen the massive blast of an ordnance weapon means it's going to be very hard to miss. Nonetheless the shot may not land *exactly* where it was intended to. Roll the Scatter dice and a D6 to see where the shot lands. If the Scatter dice rolls a HIT symbol the shot lands on target. If an arrow is rolled the marker is shifted in the direction shown by the arrow the number of inches indicated on the D6.

Any models which end up under the Blast marker will be hit automatically. Roll a D6 for models that are partially under the marker: on a 1-3 they are unharmed, on a 4-6 they are hit by the full force of the blast. Vehicles will be hit regardless of whether they are fully or partially under the Blast marker.

Resolve ordnance hits with the Strength and Armour Piercing values on the Ordnance table.

ORDNANCE BARRAGES

Some pieces of ordnance are used for laying down a barrage in the same way as mortars (though on a much larger scale). With these pieces you need to guess the range and roll for scatter just like other barrage weapons.

Place the Blast marker for the ordnance at the distance guessed and then see if it landed on target by rolling a Scatter dice and a D6 together. If you roll a HIT on the Scatter dice the shot lands at the range guessed. If an arrow is rolled the marker is shifted in the direction indicated by the arrow a number of inches equal to the roll on the D6.

Victory does not always rest with the big guns:
but if we rest in front of them we shall be lost.

Commander Argentius of the Silver Skulls

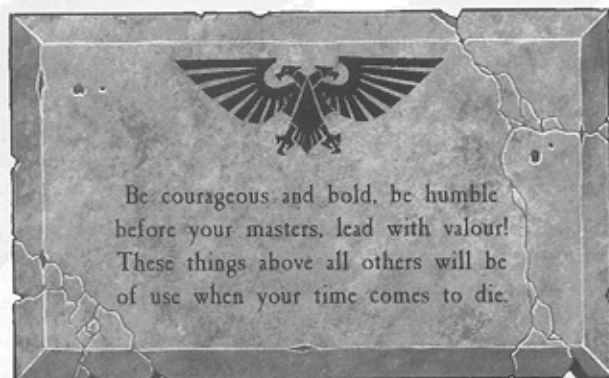
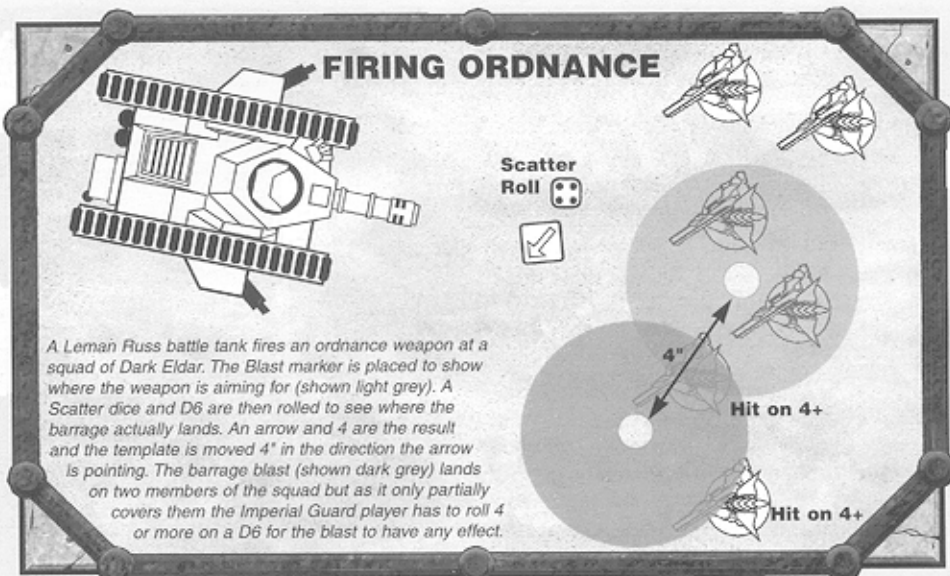

INCOMING! Ordnance Barrage Pinning

Ordnance barrages are even more terrifying than normal barrages – the ground shakes and heaves under the thunderous impacts, troops caught in the open are completely annihilated and those in cover are virtually buried alive by a furious rain of flaming death.

Units suffering casualties from an ordnance barrage must pass a Leadership test with the following modifier to avoid being pinned down:

- 1 For coming under fire from an ordnance barrage.

If the unit fails it may not move, shoot or assault in the following turn.

A unit that is pinned down does not have to take a Morale test if it sustains 25% casualties from enemy fire, the fact it is pinned overrides the Morale test. If assaulted by the enemy the unit will fight normally, ignoring the falling shells under the pressing circumstances of battle. At the end of the following turn the unit recovers and may act normally again.

SHOOTING AT VEHICLES

A vehicle is much harder to destroy than a creature of flesh and blood. Most fighting vehicles are heavily constructed from steel and tough alloys and their hulls are protected by thick armour plates, sloped or angled to deflect shots. Any hits that do penetrate may only cause slight damage or strike non-essential systems. In the case of lighter vehicles shots may simply pass straight through and out the other side without causing any damage at all! On the other hand vehicles carry a supply of fuel and ammunition that will blow them apart if they are hit, and however tough the vehicle is, its crew can be always be stunned or disabled by hits made against its armoured hide.

CHOOSING A VEHICLE AS A TARGET

When you want to fire at a vehicle treat it like any other unit. One of your units can choose it as a target and must direct all of its shooting at it. Often this means that some of their weapons can't damage it, so assume that the other members of the squad are giving covering fire, bringing forward ammunition for heavy weapons or simply keeping their heads down!

Roll to hit against vehicles in the same way as against troops. Any hits scored must then have to be rolled again to see if they penetrate the vehicle's Armour Value in order to cause any damage as explained later.

ARMOUR PENETRATION

Once a hit has been scored on a vehicle roll a D6 and add the weapon's Strength characteristic to it. Then compare the total against the vehicle's Armour Value.

If the total is **less** than the vehicle's Armour Value the shot bounces off.

If the total is **equal** to the vehicle's Armour Value the shot causes a 'glancing hit'.

If the total is **greater** than the vehicle's Armour Value the shot scores a penetrating hit.

EXAMPLE: A lascannon shot hits the front of a Space Marine Predator that has an Armour Value of 13. Rolling a D6, the player scores a 4, and adds this to the lascannon's Strength of 9 for an Armour Penetration total of 13. This equals the Armour Value of the Predator and so inflicts a glancing hit.

Further example Armour Values for different vehicles are shown on the chart overleaf.



Ordnance Weapons

Ordnance weapons fire such enormous projectiles that they can smash through armour or hit with such force that the target vehicle's crew are turned to mush. When you roll to penetrate a vehicle's armour with an ordnance weapon you get to roll two dice instead of one and pick the highest result.



By the manner of their death
we shall know them.

VEHICLE ARMOUR VALUES

Armour Values are different for each type of vehicle. They represent not just the thickness of its armour but also how difficult a target it is because of its size and speed, how tough and numerous its crew are and so on.

Armour Values for individual vehicles also vary depending on whether the shot comes from the front, sides, or rear.

In the case of a barrage weapon the shot is assumed to come from where the Blast marker landed.

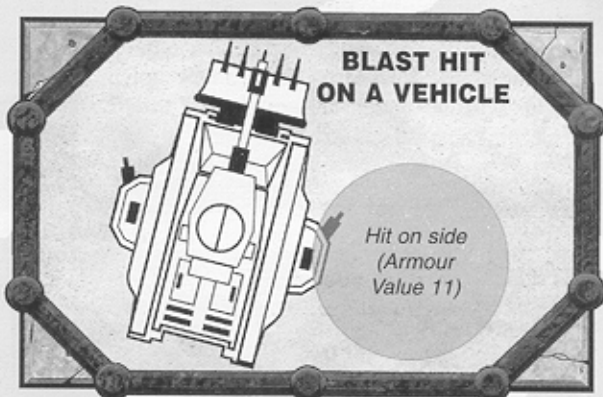
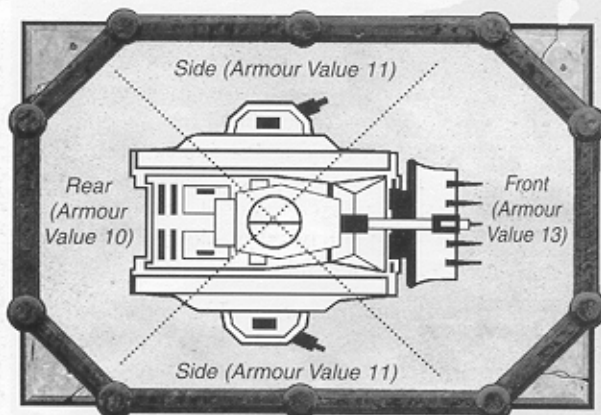
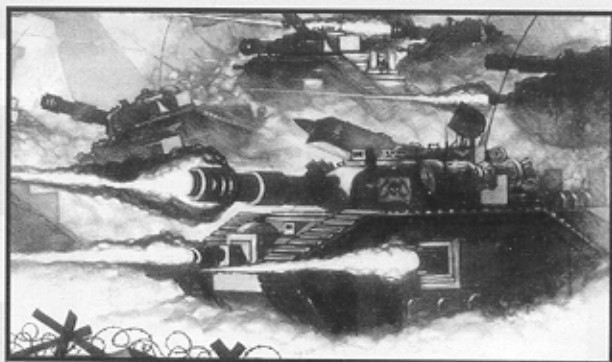

ARMOUR VALUES

	FRONT	SIDE	REAR
Land Raider	14	14	14
Leman Russ	14	12	10
Chimera	12	10	10
Rhino	11	11	10
Predator	13	11	10
Land Speeder	10	10	10
Dreadnought	12	12	10
War Buggy/Trak	10	10	10
Falcon Grav Tank	12	12	10
Wave Serpent	14	14	10
Vyper	10	10	10

D6 score for lascannon (S9) to penetrate		
front	side	rear
6	6	6
6	4+	2+
4+	2+	2+
3+	3+	2+
5+	3+	2+
2+	2+	2+
4+	4+	2+
2+	2+	2+
4+	4+	2+
6	6	2+
2+	2+	2+

The voyage across the vastness of warp space is full of hazards which are unimaginable to the common warriors of the Imperium. The greatest threat does not come from the denizens of the abyss, the daemons that gather to spacecraft as sharks to drowning men, but from the very passage of time. For there is no time in the warp and whilst weeks or months pass within a ship's warp envelope there is no accounting how many years might go by in the mortal world. Thus too often a battleforce dispatched in haste arrives at its destination centuries later to find the battle lost and themselves pitched into an alien infested hell. In this manner armies are wasted in ignorance and lives thrown upon the wreckage of time.

DAMAGE ROLLS

If a vehicle's armour is breached make a Damage roll to see what happens. Roll a D6 and look up the result on the appropriate Damage table. Note there are separate tables for glancing, penetrating and ordnance hits.



GLANCING HIT

(S+D6 ROLL EQUALS ARMOUR VALUE)

- 1-2** **Crew shaken** – The vehicle may not shoot next turn. Embarked troops may disembark and the vehicle can still move.
- 3** **Crew stunned** – The vehicle may not move or shoot next turn, embarked troops may not disembark.
- 4** **Immobilised** – The vehicle may not move for the rest of the game. Skimmers that are immobilised crash and are destroyed.
- 5** **Armament destroyed** – One of the vehicle's weapons (chosen by attacker) is destroyed.
- 6** **Vehicle destroyed!** – The vehicle is wrecked, mark it with cotton wool smoke or remove it from play altogether.



PENETRATING HIT

(S+D6 ROLL BEATS ARMOUR VALUE)

- 1** **Crew stunned** – The vehicle may not move or shoot next turn, embarked troops may not disembark.
- 2** **Immobilised** – The vehicle may not move for the rest of the game. Skimmers that are immobilised crash and are destroyed.
- 3** **Armament destroyed** – One of the vehicle's weapons (chosen by the attacker) is lost.
- 4** **Vehicle destroyed!** – The vehicle is wrecked, mark with cotton wool smoke or remove from play altogether.
- 5** **Vehicle destroyed!** – An explosion slews the wreck D6" in a direction determined by rolling the Scatter dice. On a roll of a HIT the wreck flips over onto its side or roof (whichever way it balances best, randomise if necessary). Models in the way leap aside automatically.
- 6** **Vehicle destroyed!** – The vehicle's fuel and ammo detonate, scattering flaming debris over a D6" radius measured from the vehicle's edge. Models in range suffer 1 wound on a D6 roll of 4+ (saving throws are allowed), vehicles are unaffected.



ORDNANCE HIT

(ORDNANCE WEAPON BEATS ARMOUR)

- 1** **Crew stunned** – The vehicle may not move or shoot next turn. Embarked troops may not disembark.
- 2** **Immobilised** – The vehicle may not move for the rest of the game. Skimmers which are immobilised crash and are destroyed.
- 3** **Armament destroyed** – One of the vehicle's weapons (chosen by the attacker) is destroyed.
- 4** **Vehicle destroyed!** – The massive impact slews the wreck D6" in a direction determined by rolling the Scatter dice. On a roll of a HIT the wreck flips over onto its side or roof (whichever way it balances best, randomise if necessary). Models in the way leap aside automatically.
- 5** **Vehicle destroyed!** – The vehicle's fuel and ammo detonate, scattering flaming debris over a D6" radius measured from the edges of the vehicle. Any models within range suffer 1 wound on a D6 roll of 4 or more (saving throws are allowed), vehicles are unaffected.
- 6** **Vehicle annihilated!** – The vehicle is blown to pieces by the shot. Red hot fragments of armour, engine and weaponry are sent scything in a 6" radius measured from the edges of the vehicle. Any models within range suffer 1 wound on a roll of 4+ (saving throws are allowed), other vehicles are unaffected. Remove the destroyed vehicle model (only a smoking crater is left behind).

NOTES

Crew & Passengers: Vehicle drivers, gunners and other crew are automatically killed if their vehicle is destroyed. Troops embarked on a vehicle that is destroyed each suffer 1 wound on a D6 roll of 4 or more, but may take their Armour saving throws. Survivors are placed within 2" of the wreck. A vehicle annihilated by a 6 result on an Ordnance Penetrating hit will have no survivors.

Stun results: Crews stunned more than once only miss their next turn, don't add the stuns together. A Skimmer with stunned crew drifts D6" in a direction indicated by rolling the Scatter dice in its next movement phase (but stays facing the same way). A stunned Dreadnought can not fight in close combat for the following turn.

An immobilised vehicle may not turn in place and if it receives a second immobilised result, its turret and any sponson weapons are jammed pointing in the direction they last fired. Weapons jammed in place can only fire at units directly in their line of fire.

Open-Topped Vehicles

Some vehicles are more vulnerable to damage than others because of their lightweight construction and the fact that their crew is exposed to enemy fire. A typical example of an open-topped vehicle is an Ork Wartrak or War Buggy. Whenever a Damage roll (glancing or penetrating) is made against an open-topped vehicle add +1 to the Damage result.

Template and Blast marker weapons are particularly dangerous to open-topped vehicles because their crewmen, wheels, engines and other components are not protected against the flames and shrapnel. To represent this template and Blast marker weapons cause **double** the normal number of hits against light vehicles (ie two hits instead of one).

Skimmers Moving Fast

Moving skimmers are very difficult to hit squarely because they are more agile than other vehicles, and most shots are more likely to 'wing' them instead. To take account of this, any hits that would penetrate a skimmer that moved more than 6" in its movement phase count as glancing hits instead.

The Hull Down Rule

Vehicles do not gain benefits from cover in the same way as infantry. However, vehicles can move into protected positions and use terrain to mask their more vulnerable parts in the following way.

Any vehicle that is in or behind cover (eg a wall, the crest of a hill, a wrecked vehicle, woods or jungle, or something similarly substantial) is considered to be 'hull down'. A hull down vehicle is trying to keep itself out of the line of fire as much as possible, so it counts all penetrating hits as glancing hits instead as shown in the diagram below.

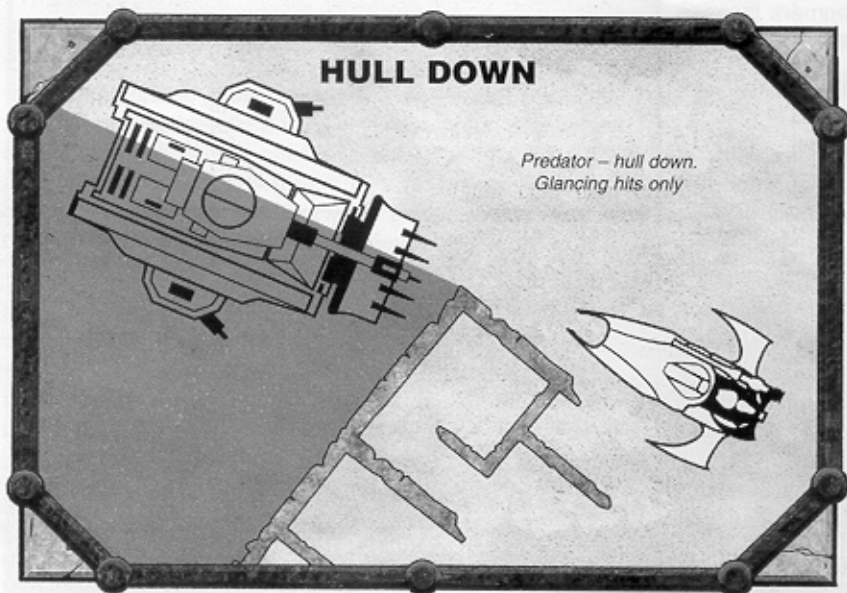

Smoke Launchers: Some vehicles have small launchers mounted onto them that carry smoke charges (or a more sophisticated equivalent in the case of skimmers). These are fired off to temporarily hide the vehicle behind concealing clouds of smoke, and are most often used when it is moving in the open. Once per game, after completing its movement, a vehicle with smoke launchers can trigger them (it doesn't matter how far it moved). Place some cotton wool around the vehicle to show it is concealed by smoke.

The vehicle may not fire in the same turn as it used its smoke launchers, but any penetrating hits scored by the enemy in their next shooting phase count as glancing hits. After the enemy's turn the smoke disperses with no further effect.

VEHICLE UNITS

Most vehicles fight as individual units and are represented as a single model. However, some vehicles like Ork Wartraks and Eldar Vypers operate in units of more than one vehicle rather like troops, usually with up to three vehicles in a unit.

Moving

When a unit of vehicles moves they all have to move at roughly the same speed, eg they all move up to 6" or they all move up to 12" etc. Once all the vehicles have moved they need to be within 2" of each other, just like ordinary troops. Only mobile vehicles stay together like this; if any of the vehicles in the unit are immobilised for any reason they can be ignored and left behind by the others in the unit.

Shooting

When shooting, a unit of vehicles fires all of its available weaponry at a single opposing unit. When a unit of vehicles is fired at any hits are distributed evenly amongst the vehicles, starting with the nearest vehicle model. No vehicle takes more than one hit until all of the vehicles in the unit have taken one hit each. Once the hits have been distributed roll to penetrate armour and make any damage rolls as appropriate.

EXAMPLE: An Ork Trukk fires its big shoota at a squadron of two Vypers, and scores two hits. This is divided between the Vypers, one hit on each, rather than both hits on a single Vyper.

VEHICLES IN AN ASSAULT

Vehicles don't fight in close combat as such although they can be attacked by enemy troops. However, heavy vehicles like tanks can break through enemy positions, scattering units and possibly forcing them to fall back – this kind of attack is called Tank Shock and is described below. Dreadnoughts, giant humanoid walking machines designed to spearhead assaults, and other walkers fight in close combat the same way as troops do.

Skimmers

Skimmers can always choose to move over enemy troops and this neither impedes their movement nor harms the troops below. Enemy troops can attack skimmers in the assault phase, as close combat takes into account close range shooting and grenade lobbing as well as actual hand-to-hand combat.

Skimmer tanks can still choose to overrun an enemy unit and inflict tank shock in the normal manner.

TANK SHOCK

Tanks can overrun enemy troops during their move phase. Having some monstrous metal behemoth coming straight at you is unnerving for anybody.

During their movement phase a player can declare that a tank is going to attempt to overrun an enemy unit. If the tank has sufficient movement to get into contact with the unit, the enemy must take a Morale check.

To use Tank Shock declare which enemy unit you are driving at with which of your vehicles, and how fast it is moving. Then measure to see if any models from the unit will be reached by the tank. If the tank reaches the unit take a Morale check.

If they fail the check the unit falls back 2D6" – individual models are allowed to be moved out of the path of the vehicle if they would otherwise end up underneath it. The unit can check to see if it is able to regroup in its own turn as normal – but troops will not be allowed to regroup if there is an enemy unit within 6" (such as the tank that forced them to fall back!).

If a unit is moved over by a tank and it passes its Morale check, individual models can be moved out of the way if they would end up underneath it, but otherwise the unit is



unharmd. The troops are assumed to move out of the way and resume their positions as the tank passes. Remember that vehicles cannot move over friendly troops, or over vehicles (or wrecks) from either side.

Death or Glory!

If a unit passes its Morale check against Tank Shock any troopers from the unit can stand in the path of the vehicle and shoot at it, rather than move out of the way. This is potentially a rather suicidal thing to do! Each model nominated for this heroic duty gets one shot at the tank as it heads towards him. He hits automatically, resolve the hit against the tank's front armour immediately. Then, unless he has destroyed or stopped it, he gets crushed to death by the tank grinding over him – the model is killed regardless of wounds or armour (invulnerable or not!).

A Crew Stunned result stops the enemy vehicle for the rest of the turn in this case, halting 1" in front of the unit.

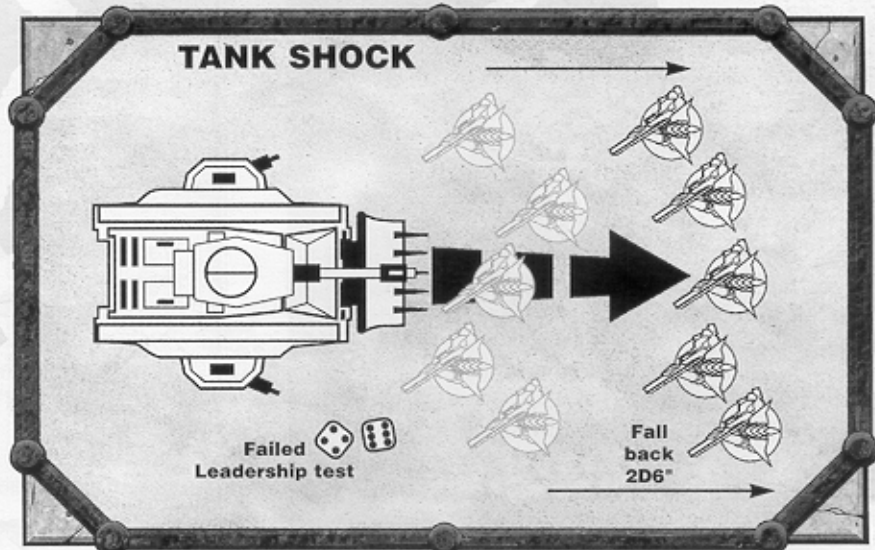

INFANTRY ASSAULTING VEHICLES

Infantry can pose a grave risk to vehicles if they get close enough. With the right weapons troopers can wreck a vehicle by shooting through vision slits, planting explosive charges on fuel tanks, tearing open hatches to attack crew members or committing some other equally imaginative act of mayhem.

As mentioned above vehicles don't take part in close fighting in the same way as units of troops. However, a squad of troops can assault a vehicle and attempt to destroy it. This works as follows.

Launching an Assault

A squad can assault a vehicle by moving 6" towards it, getting into contact in the same way as when assaulting enemy squads. Individual models must move into contact where possible and take the shortest route to reach the vehicle. This means that troops are not allowed to go round the sides or rear of the vehicle unless they start their assault at the sides or the rear.

Hits

Troops attack with the normal number of attacks: +1 if double armed or +1 because they are assaulting that turn. All attacks automatically hit a stationary vehicle. Vehicles moving 6" or less in their previous turn are hit on a 4+. Vehicles which moved faster than this are only hit on a 6. WS counts for nothing in this case! Skimmers can only ever be hit on a 6 regardless of whether they moved or not.

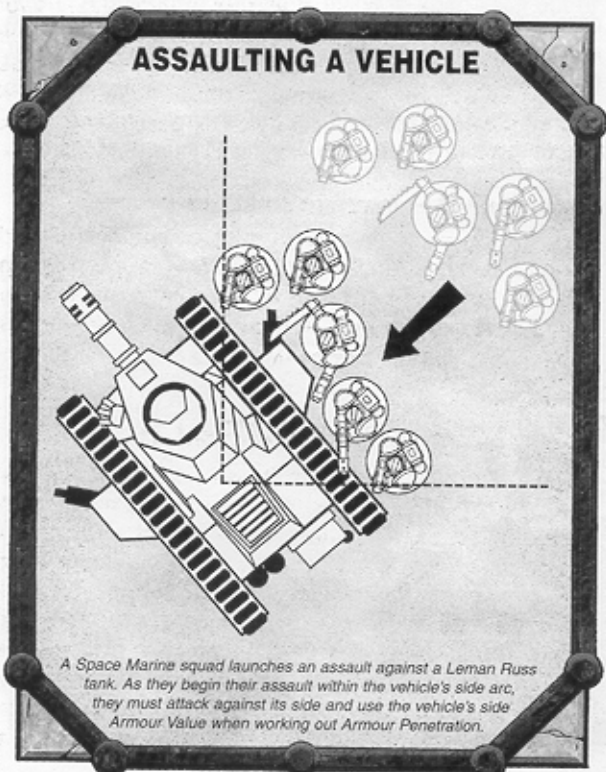

An open mind is like a fortress with its gates unbarred and unguarded.

Damage

Penetration is worked out as normal, (D6 + the Strength of the attacker). Note that this means few troops can actually harm vehicles as even the lightest vehicle has an Armour Value of 10.

Results

No results are counted for close combat against vehicles. The vehicle simply moves away as it wishes in its next turn, while the troops who mounted the assault are free to move, shoot etc normally. Thus assaults against vehicles are very easy to work out – just make your attacks and work out any damage.

Monstrous Creatures

Monstrous creatures are so big and powerful that they roll an extra D6 to penetrate vehicle armour, so their Armour Penetration value is equal to 2D6 + the Strength of the creature.

Melta Bombs

Specialist tank hunting troops are often equipped with melta bombs – fusion based thermic charges which can reduce a battletank to a burnt-out wreck in milliseconds. Troops armed with melta bombs can treat any of the hits they score in an assault on a vehicle as close range melta gun hits (Penetration S8 + 2D6).

However, melta bombs need to be clamped in place before activating so each model using them makes only one attack and doesn't count bonus attacks for charging, extra hand weapons, etc. Melta bombs can be used in a Death or Glory attack against a tank attempting to overrun.

Krak grenades

Some troops are equipped with krak grenades, a special type of grenade designed to implode, shattering armour and (hopefully) stopping vehicles in their tracks.

Troops equipped with krak grenades can use them to assault vehicles. Krak grenades give troops S6 for close combat hits scored against vehicles, making their Armour Penetration scores 6+D6. Krak grenades need both hands to trigger so models using them can only make a single attack and don't get bonus attacks for charging, additional hand weapons or anything else. Krak grenades can also be used to make a Death or Glory attack on an overrunning tank.

DREADNOUGHTS IN AN ASSAULT

Dreadnoughts fight in an assault in the same way as infantry. Resolve any hits scored on Dreadnoughts by rolling for armour penetration and damage as for a vehicle. As with other vehicles, troops are not allowed to dash round the sides and go for the rear armour of the Dreadnought unless they start their assault from the sides or rear. Each Damage roll that is inflicted on a Dreadnought counts as a single wound for the purposes of working out who won the combat.

There is one very important difference about Dreadnoughts in an assault. Dreadnoughts never have to check morale, and so will never fall back in an assault. Even if the Dreadnought has lost, count the result as a drawn combat. The only way to win a close combat involving a Dreadnought is to destroy it!

Drawn Combats

In a drawn combat a Dreadnought can move up to 6" to attack unengaged models or turn to face its attackers if being assaulted from the side or rear. Any unengaged attackers can move in to surround a Dreadnought in order to attack its sides and rear (if there's room).

Multiple Combats

In multiple combats where there is a Dreadnought (or several Dreadnoughts) on one or both sides the infantry units have to check Morale if they lose as normal. In the event that any of the infantry falls back the Dreadnoughts remain in combat. As normal, winning units (including Dreadnoughts) can only advance or consolidate if all of the units fighting them fall back.

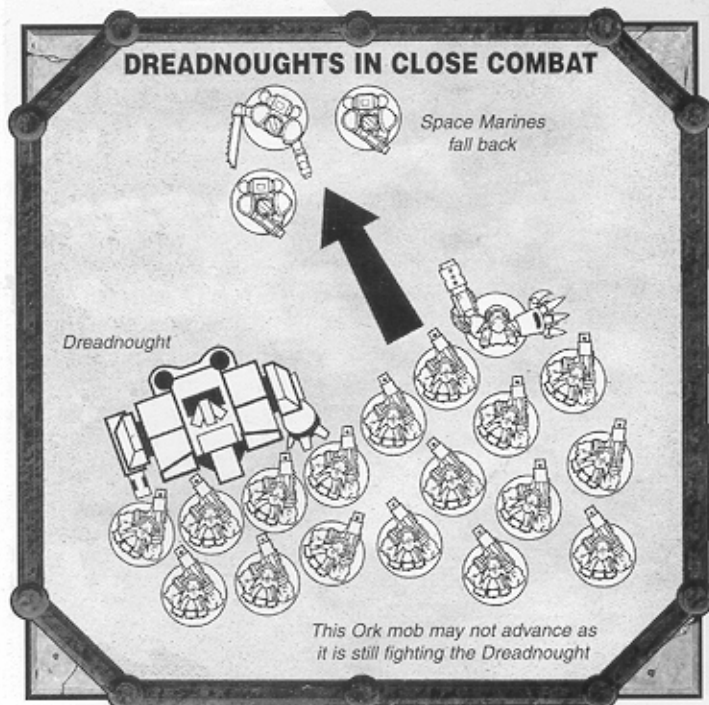

Forged in the minds of madmen, the Dreadnought is the consecrated resting place for the ancient Space Marine veterans. Those whose skills in battle are too precious to be allowed to die are kept entombed within its armoured bulk to serve their Chapter and the Emperor for another thousand years of war.



Dreadnought Close Combat Weapons

Dreadnoughts are often armed with enormous close combat weapons – hammers, wrecking balls, claws, etc. If a Dreadnought is armed with a close combat weapon it doubles its Strength in close combat (up to a maximum of 10) and ignores armour saving throws. In other words, for Dreadnoughts close combat weapons count as power fists, but it strikes according to its normal Initiative value instead of always striking last.

A Dreadnought armed with two close combat weapons gains an extra Attack just like ordinary troopers armed with two weapons.

Immobilised Dreadnoughts In Close Combat

Immobilised Dreadnoughts can still fight back in an assault, but their number of attacks is reduced by 1 for each immobilised result they have received. Krak grenades and melta bombs are useless against a mobile Dreadnought but they can be used against Dreadnoughts if they are already stunned or immobilised at the start of the close combat.

Other Walkers In Assaults

Gun platform walkers such as Imperial Guard Sentinels and Eldar War Walkers can fight in close combat as Dreadnoughts. Unfortunately their low Strength and number of Attacks means they are simply not very good at it!

VEHICLE MORALE

Vehicles don't normally check morale for any reason, whether they are clanking great behemoths or arrow-quick attack craft. It is assumed that in all cases the vehicle's crew has unshakeable faith in both their vehicle and you as their supreme commander (as is often the case with vehicle crews). In special circumstances you might want to introduce special rules for inexperienced crews, tanks being driven off by penetrating or glancing hits and so on.

JUMP PACK TROOPS

Some special troops wear devices that allow them to move at great speed across the battlefield. This makes them especially good at assaulting enemy troops but also allows them to make sweeping advances around the unguarded flanks and rear of enemy positions. These devices, normally only used by special troops, are generally called jump packs but they vary immensely from race to race. For example, Space Marine Assault troops and Ork Stormboyz use screaming jet turbines to provide the lift needed to move a fully armed warrior across a battlefield, while Eldar Swooping Hawk Aspect warriors soar aloft on raptor wings of light alloys powered by a silent gravitic motor. Jump pack troops also include more exotic types of warrior such as Eldar Warp Spiders who use teleport devices to achieve their mobility and Chaos Daemons who use their supernatural powers.

Whatever their type, jump pack troops fight in squads just like other troops. They check morale in the same circumstances as ordinary troops – enemy fire, losing an assault and tank shock.

Jump Pack Movement

Jump pack troops can move up to 12" during their movement phase. A unit of jump pack troops can charge 6" in the assault phase if it is within 6" of the enemy. In other words they move at twice the speed of troops on foot, but assault the normal distance.

As jump packers fly through the air they ignore the effects of terrain unless they move in it. Jump pack troops are affected by terrain differently to infantry because they won't be delayed by it – they will either land safely or not. If jump pack troops enter difficult terrain roll a D6 for each model in the unit. On a 2-6 the model lands without incident, on a 1 the model crashes into the trees, rocks or whatever and is removed as a casualty. No armour saves are allowed.

Jump Pack Troops Shooting

Jump pack troops can shoot with their weapons using their BS. All the normal rules apply so if the entire unit remains stationary they can use any rapid fire weapons



they are carrying at full effect. Heavy weapons cannot be fired by moving jump packers, but may be fired if the unit is stationary.

Shooting At Jump Pack Troops

Jump pack troops can be fired upon as if they were infantry. Use the troops' Toughness to see if any hits cause wounds. Jump pack troops are allowed to take saving throws as normal.

Jump Pack Troops In Assaults

Jump pack troops fight in close combat just like other troops, using the troops' characteristics for WS, S, A and so on. Because of their great speed jump pack troops can advance 3D6" after an assault and fall back 3D6".

CAVALRY

As well as squads of warriors fighting on foot, the armies of the 41st millennium include troops which ride into battle on horses, grunting Cyboars, daemonic steeds and other strange creatures. Such horse-sized creatures and their riders are referred to as *cavalry*. Troops may also ride into battle on bikes, trikes or similar vehicles, these are dealt with separately in a later section.

Cavalry fight in squads just like other troops with a 2" coherence distance. They check morale in the same circumstances as ordinary troops – enemy fire, losing an assault and tank shock.

Cavalry Movement

Cavalry can move up to 6" in their movement phase. A unit of cavalry can charge 12" in the assault phase if it is within 12" of the enemy. In other words they move at the same speed as troops on foot, but assault twice as far. Cavalry mounted on particularly exotic beasts might charge faster or slower than this, where this is the case it will be noted in their description.

Cavalry are affected by terrain in a different way to infantry, being likely to either plunge through it or fall prey to a mishap rather than be delayed. So if cavalry enter difficult terrain roll a D6 for each model. On a 2-6 the model rides through any hazards unscathed, on a 1 the model has a nasty accident (eg stumbles in a pothole, rides into a low branch) and is removed as a casualty. No armour saves are allowed.

Cast out the mutant, the traitor, the heretic.
For every enemy without there are a hundred within.

Cavalry Shooting

Cavalry riders can choose to shoot their personal arms using their BS. All the normal rules apply so if the entire unit remains stationary they can use rapid fire weapons carried by the riders at full effect. Heavy weapons cannot be fired by moving cavalry, but may be fired if the unit is stationary (it can be imagined that the riders dismount to fire while they are halted).

Shooting at Cavalry

Cavalry are fired upon like infantry, use the rider's Toughness to see if hits cause wounds. They are also allowed to take saving throws as normal, although they can only take advantage of cover if they remained stationary during their previous movement phase.

Cavalry in an Assault

Cavalry fight in close combat just like other troops, using the rider's characteristics for WS, S, A and so on. Because of their great speed cavalry can advance up to 3D6" after an assault and fall back 3D6".



Across the void of space men live as they have lived for millennia upon the sand, rock and soil of worlds bathed in the light of alien suns. So is Humanity's seed cast far and wide beyond the knowledge of Man, to thrive bitterly in the darkness, to take root and cling with robust and savage determination.

BIKES

Bikes are amongst the most numerous vehicles of the 41st millennium and are used by a multitude of races for a variety of purposes. The Space Marines use bikes for lightning assaults and reconnaissance missions and the Eldar use jetbikes powered by anti-gravitic motors for the same purpose.

All of these armies are renowned for their ferocious assaults and fast moving battlelines. Their bikes allow them to outmanoeuvre and overwhelm their foes at key positions. The Dark Angels Chapter of Space Marines has an entire company known as the Ravenwing, all mounted on bikes and similar light vehicles who are justly famous for their skill at handling their mounts.

Bikes are treated as troops rather than vehicles – albeit they are much faster than your average trooper. They share some rules in common with vehicles, but are best thought of as fast, mobile, extra-hard hitting troops. In almost all circumstances the bike rider's characteristics are used.

Bikes fight in squads just like other troops with a 2" coherence distance. They check morale in the same circumstances as ordinary troops – enemy fire, losing an assault and tank shock.

Bike Movement

Bikes can move up to 12" in their movement phase. A unit of bikes can charge 6" in the assault phase if it is within 6" of the enemy. In other words they move at twice the speed of troops on foot, but assault the same.

Note that certain types of bikes are able to move much faster than this. Special values for these bikes will be included in the Codex army books where they are appropriate.

Bikers are affected by terrain like vehicles, but are put out of action if they become immobilised. If bikers enter difficult terrain roll a D6 for each model. On a 2-6 the bikers steers skilfully through the hazards, on a 1 the biker hits a tree, rock or something else solid with tragic consequences and the model is removed as a casualty. No armour saves are allowed.

Bikers Shooting

Bike riders can choose to shoot either personal arms or bike-mounted weapons using their BS. If the entire unit remains stationary they can use rapid fire weapons carried by the riders at full effect.

As weapons are firmly mounted with plentiful ammunition supplies, any weapons mounted on a bike can fire as if they were stationary even when the bike has moved. Hence any rapid fire weapons mounted on a bike always get two shots at targets up to 12" away or one shot at targets up to 24" away. Even heavy weapons can be fired by moving bikes.

Shooting at Bikes

Bikes have an equivalent Toughness and Armour to the troops riding them, but receive a Toughness bonus of +1. This reflects the protection offered by the bike's armoured bodywork.

Bikers are allowed saving throws as normal, although they cannot take advantage of cover.

Bikes in an Assault

Bikes fight in close combat just like other troops, using the rider's characteristics for WS, S, A etc. In close combat the riders continue to gain the +1 Toughness bonus from their armoured mounts.

Due to their great speed bikes can advance 3D6" after an assault and fall back 3D6".

ATTACK BIKES

Attack bikes carry two crew and usually mount a heavy weapon on a side car or similar arrangement. Attack bikes function in almost the same way as bikes but can fire two weapons in the shooting phase and have an improved save to account for their two crew. In close combat an attack bike is treated as a single trooper with two attacks.

ELDAR JET BIKES

The Eldar use bikes powered by anti-gravitic engines so that they can hover a few meters above the ground and make powered boosts over obstacles. This means that they combine the utility of bikes with the best aspects of skimmers. Jetbikes work like ordinary bikes but can pass over and ignore terrain when they are moving. Jetbikes which begin or end their move in difficult terrain must test to avoid crashing. Roll a D6. On a 1 they crash and burn. Other than this jetbikes shoot and fight in assaults just like other bikes.



AGE OF THE IMPERIUM





Bring fire and bring shell and heap all upon the pyre. With flame and gun we shall make an end to the withered husk that is human life. And in the blazing furnace of battle we shall forge anew the iron will of a yet stronger race.



As wriggling maggots upon a rotted corpse they glut themselves upon the rank flesh that is the Earth. Such is mankind, blind and bound to a dying world, nought but the writhing worm that mires itself in the corruption of its own progenitors. They who feast today do so in ignorance of their mortality. For tomorrow they must die or change, and, if changing, then forever open their eyes to the dark hunger of eternal life.



Let the Flames of Battle Consume Us!



THE IMPERIUM OF MAN

A MILLION WORLDS, UNNUMBERED SOULS

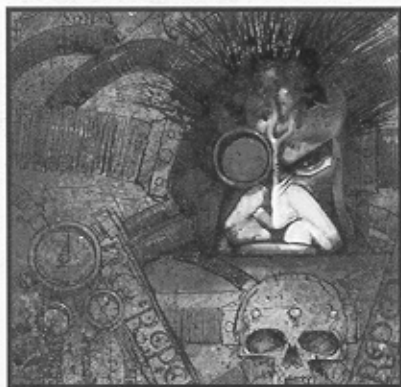

For 10,000 years, the galaxy-spanning Imperium of Mankind has been the bastion of the human race. With over a million worlds and a population running into countless thousands of billions, it is the largest empire in the galaxy of the 41st millennium. For a hundred long centuries the Imperium has endured, surviving disasters, heresies and invasions from alien races intent on the extinction of humanity. It has resisted all of this through its greatest strengths – the immortal Beneficent Emperor of Mankind and his vast armies and fleets.

Though the Emperor is a shattered, withered creature, he still watches over and guides humankind from the restorative essences, elixirs and billowing alchemical gases of the Golden Throne of Terra. Through his vast psychic powers, the Emperor directs the Imperium's warships through the nightmare realm of warp space. He foresees the possible

"Mankind stands upon the brink; on the one hand lies a realm of unimaginable power, on the other awaits darkness, death and utter damnation. Only those that follow the guiding light of the Emperor may save their souls."

Inquisitor Damarn, Ordo Malleus

futures of the human race, and steers humanity so that it may overcome the many trials and challenges ahead.

Without the Emperor, the Imperium would be unable to move its armies and fleets to combat its enemies and enforce its rule. The Imperium would degenerate into a hundred small empires clamouring for power while aliens and other monstrous creatures devoured and destroyed Mankind.

The tide of the Emperor's enemies is only held back by the vigilance of the Imperial fleets and the weapons of humanity's armies. Millions of soldiers fight over a thousand worlds against every conceivable type of foe: from the all-consuming Hive Fleets of the Tyranids and the rampaging invasions of the warmongering Orks to rebellion and insurrection from within.

Alongside the vast might of the Imperial Guard, the superhuman Space Marines of the Adeptus Astartes bring terror and death to the Emperor's foes. The elite Space Marines are the deadliest fighting force humanity can send to battle – just a few squads of these genetically engineered warriors can crush an army of foes many times their number. In the cold depths of space gigantic battleships, accompanied by armadas of other vessels, bring battle to raiding Eldar pirates and Ork hulks.

Internecine wars are commonplace and often mankind faces its greatest threat from within. Rebel governors, corrupt commanders, alien-possessed officials and even the Primarchs of the Space Marines have all turned against their peers and spilt human blood in the Imperium's long, war-torn history.

The Imperium itself is inconceivably vast, spanning many thousands of light years that require months, even years, of travel to traverse it. A million worlds with a million different cultures make up humanity, and the discovery



of new star systems and new planets are forever expanding the Emperor's domains, fuelling mankind's eternal hunger for more resources, more space.

Even to systems close to Earth, the Emperor and the Imperium he embodies are but names for distant, almost supernatural forces, that are revered and praised from afar. Many citizens labour their entire lives, overcoming strife and toiling hard to survive the adversity of life in the

41st millennium, without even being aware of the Imperium except as a children's story. For others the Imperium is very real, the iron fist of control tight around their lives, instilling the law and order mankind must have to prevail.

Harsh discipline and little mercy are essential for survival in these turbulent times. It is an age of great upheaval for humanity. With every passing year more and more people display powerful psychic talents. If these rogue psykers are not controlled or purged, the erratic and awesome forces they can unwittingly unleash may destroy whole settlements, even worlds. Those with the necessary mental strength and fortitude can be trained by the forces of the Imperium to use their strange powers to benefit mankind.

Those who lack this power of will must be cleansed. Citizens with psychic talents who are left free to roam will often become unwitting pawns of malevolent warp entities, who use the increased mental

powers of untrained psykers to bridge the gap between their realm in warp space and the galaxy of mankind. From here they spread their dominance, creating slaves of whole planetary populations and destroying the fabric of the Imperium from the inside.

Other mutations are becoming rife. A malignant epidemic of mis-shapen and evil creatures threatens to turn humanity into a race of degenerated beasts, unable to defend themselves from the forces that oppose them. The pogroms against mental and physical deviants cannot falter, lest mankind be engulfed and consumed by the powerful evolutionary processes at work. These abhorrent elements must be crushed or somehow tamed if mankind is to survive the transformation into a new era of spiritual and physical supremacy.

As powerful as it is, the Imperium does not rule the entire galaxy. Mankind's worlds are spread thin across the 200,000,000,000 stars



that make up the galaxy. Within the Imperium's vague borders are rebellious enclaves of human worlds, domains ruled over by alien war leaders, colonies of creatures too aloof or basic to disturb mankind or draw the attention of the war fleets. The Imperium is engulfed in a constant state of war, sometimes simply continuing its wars of expansion, other times fighting against foes who threaten the survival of the entire human race.

WARP SPACE

The greatest human colonisation of the galaxy began tens of thousands of years before the Age of the Imperium, when it was discovered that the universe is a mixture of different dimensions interacting with each other. The material world as we know it is one of these dimensions and warp space (or the warp) is another, also known as Chaos, the Ether, the Empyrean and the Immaterium.

The warp does not conform to the laws of physics and nature as we know them, but is filled with swirling energy. Warp technology concerns itself with the study and exploitation of the warp, and its most important achievement has been the development of warp travel.

Space craft can navigate vast distances across the galaxy by dropping into the alternate world of warp space, where time has no meaning and distance is constantly fluid and deceptive. A journey that may take centuries in real space can be traversed in a matter of weeks in

"For the warp is a strange and terrible place. You might as well throw a traveller into a sea of sharks and tell him to swim home as send him through the warp unprotected. Better it is not to let common man travel through the stars. Better still, let him not know such a thing is feasible."

Fra Safranc, 5th aide to Navigator Da'el. Comment made prior to the departure of the second mission to search for the missing freighter 'Pride of Angelus'.

the warp. The warp is a realm of eddies, currents and tides. Just as a river or ocean may have swirling eddies and raging maelstroms, or deeper, slower portions, so too does the warp.

Ships in warp space do not navigate as such, but merely move from one stream of energy to another, cruising the flow of the immaterium to their jump point into real space. Short jumps, although by no means safe, can be made with a fair degree of reliability and precision. Longer jumps are unpredictable and dangerous.

The tides of warp space move in complex and inconsistent patterns: ships attempting longer journeys often end up wildly off course. Were this limitation to apply to all warp travel then humanity would not have spread throughout the galaxy as it has. It is possible to make prolonged jumps of many light years by steering a ship within the warp itself: directing the craft towards a point in the material universe by sensing and responding to its current movements. Only the strange human mutants known as Navigators can pilot a craft through the warp in this way.

THE ASTRONOMICAN

For humans, warp travel is made possible by the presence of the Astronomican. Projected from earth by a ten thousand-strong choir of specially trained psykers, this beacon acts as a focus for ships in the warp. The prodigious amounts of mental energy needed to contribute to the Astronomican drains a psyker of his life essence in a few short months and hundreds die every day, their shrivelled corpses replaced by legions of fresh recruits.

The psychic beam stretches across 70,000 light years of space, a focus for the millions of commercial craft and warships that navigate through the tumultuous waves of the warp. The Navigators who guide human ships need the Astronomican, and without it the Imperium would fragment as warp travel became utterly hazardous and Imperial authority would be impossible to enforce. It is for these reasons that the beacon is often referred to as the Light of the Emperor, the Golden Path or the Ray of Hope by those who travel the warp frequently.



"The Revered Houses of the Navis Nobilite are one of the bastions upon which the Imperium is founded and the institution claims it can trace its ancestry back to the birth of our Great Empire.

The Great Families of the Navis Nobilite are uniquely composed of a particular form of human called a Navigator. Tech-adepts have speculated widely over the development and nature of the Navigators' unusual talents and many cast hints at shadowy genetic transmutation and interbreeding during the founding of the Navis Nobilite. Whatever their origins, the Navigators today are a glorious and esteemed organisation, loyal to the Imperium and stalwart in their faith. The peculiar powers of the Navigators can only be preserved by intermarriage; breeding with mundane humans eliminates the special abilities. This factor has led to the development of the closely-related Navigator families and the Navis Nobilite as a whole."

Preface - Historia Et Structura
Res Navis Nobilite

HAZARDS OF THE WARP

Warp space can be likened to an ocean, and, like the ocean, has its currents and its still spots, its whirlpools and its tempests. Storms sweep through this immaterial realm, spinning craft out of control for light years around, destroying all those embroiled in its merciless energies. In addition to the physical and spiritual peril of those caught in a warp storm, these maelstroms of energy obscure the signal of the Astronomican, making navigation in the vicinity difficult if not impossible. It is whispered, but not proven, that some do survive, and there are tales

of ships being thrown thousands of light years off course, or hurled backwards or forwards through time, destined to wander the stars for eternity with no chance of ever returning home.

Worlds can be cut off from the rest of the Imperium by warp storms that last for months, years or even centuries. These tempests can appear from nowhere, engulfing stars and planets for an unknown length of time. Some are permanent, while other warp storms may sometimes 'blink' for a few months, making travel possible,

though still highly dangerous. During these brief moments of peace the ships of the Imperium arrive, demanding the Emperor's tithes and recruiting new warriors for its fleets and armies. Many worlds are only barely aware of the Imperium's existence, a dimly remembered name or legend that tells of a powerful Emperor and his mighty armies who stand in readiness for the day of judgement.

Warp storms are not the only dangers within the warp. Like real space, the warp is inhabited. Sentient energies and other immaterial lifeforms dwell within it: creatures formed from and sustained by the shifting energies of the warp. Few are friendly; most are predatory and hostile. These entities thrive on the thoughts and emotions of those who dwell in the material universe, through possession of the weak nurturing their foul ambitions of power and conquest.

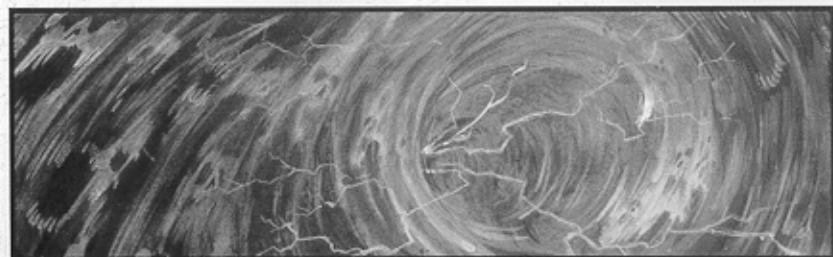



With the light of the Astronomicon on the wane, the Navigators had a difficult time directing the fleet. Admiral Adroa ordered the fleet to proceed slowly, breaking from the Emyrean every handful of light years. In this manner we

crawled through the shadow realm of the Halo Zone, paving the way for the most esteemed Lord Commander.

We investigated many stars and worlds, almost all dead for a million generations. On occasion we found evidence of ancient and depraved human societies, on others traces of foul alien races thankfully long extinct. However, in our search we did encounter worlds that still harboured life, both human and alien.

These human colonies had survived from the Dark Age of Technology, although not without change. Both physically and culturally, they had mutated or degenerated in some way. Our first unpleasant encounter was a world run by a huge machine, whose occupants were bound into the great edifice, and their young assimilated into the great engine by soulless beasts of metal. For a thousand thousand generations these vile creatures had endured, with no purpose other than to fuel and serve the oppressive ideals of their distant ancestors. Lord Macharius saw no other option than to order the world destroyed from orbit, such affronts to the Emperor cannot be allowed to exist.

In the beetle-infested jungle of the world "Palus Olidus" we fought and cleansed a race of multi-limbed aberrations who swung through their arboreal homes like vile spiders. Others too were deemed too horrific to survive, such as the bird-like monstrosities we came across just before Ultima Macharia, whose unholy evolution could only be traced by their human visages. Then there were the sea-dwellers of Altanist VI who lived their entire lives on massive ocean-going vessels of ancient design. They never set foot on land, fearing it to be toxic. We left behind Tech-Adepts and Missionaries to disarm them of their wayward beliefs and bring them into the Emperor's Forgiveness.

Not only sub-human civilisations await the explorer. In our years of travel we encountered a single planet that harboured life that owed nothing to the expansion of mankind. Our first envoy to the planet came back reporting a noble civilisation worthy of contact. While this heretic was chastised for his blasphemies, we dispatched Confessor Golav who was horrified by the tentacled beasts who greeted him in a most savage fashion. I ordered the planet fusion bombed, but as our weapons were brought to bear, the despicable heathen scum unleashed their planetary defences, totally vapourising the Sword of Retribution and the capital ships Emperor's Mercy and Emperor's Judgement. We were forced to retreat from this baseless attack and sowed quarantine markers before dropping into the Immaterium.

Extract from General Sejanus' 'Breaching the Darkness'

Occasionally the link between warp space and the material realm is weakened and energy from the warp will burst through and create a vortex of power, destroying stars and planets. There are several such warp/real space interfaces throughout the galaxy, the largest of them being the Eye of Terror and the Maelstrom. These regions cannot be traversed except by the most experienced Navigators, and such are the hazardous conditions that virtually no expeditions into these areas return. Those that do speak of a nightmare region where nature and physics are forgotten, and madness and confusion reign. They speak of worlds whose skies burn with fire, of planets seething with seas and rivers of blood, disc-shaped worlds, heavenly bodies with screaming faces and other tormented features shaped by the merest whim of the powerful deities that are formed from Chaos. As for the inhabitants of

these grim realms, some things are best left unspoken.

Warp travel between some areas is vastly improved by the presence of ancient warp gates. Although their creators remain a mystery of the dim prehistory of Earth, warp gates can be found across the galaxy. These portals into the immaterium link to another warp gate through a stabilised tunnel, enabling ships to travel through them with only negligible risk. However, the stability of the tunnels often means these journeys are slower than those through ordinary warp space, and most warp tunnels are no more than a few light years from gate to gate. Many experienced captains, especially those with perishable cargoes, prefer to risk open warp space rather than using a warp gate, in the hope of catching a fast-moving tide of power to their destination.



IMPERTIUS DOMINATUS

4DF23RT7689

SEGMENTUM
OBSCURUS

OCULARIS
TERRIBUS

Magnitude: 20

Magnitude: 7.9
Sector: 26.1/02

Magnitude: 7.0
Sector: 149/04

7YU23RP7211

2-5 WEEKS

1-3 W

1-2 MONTHS

4-7 WEEKS

3-7 WEEKS

ROUTE PROJECTION

SEGMENTUM
SOLAR

2-3 MONTHS

1-7 MONTHS

3-6 MONTHS

3-5 MONTHS

6UY45MI9967

DELTA: 1 Rega .Gamma .Echo

SEGMENTUM
PACIFICUS

ANCIENT TERRA

Blessed in his authority, here
dwells the most beneficent Emperor

3MR56TN3357

Imperial Promise Palace

Imperial Palace

SEGMENTUM
TEMPESTUS

IMPERIAL ASTRO STATION: DC/74/96

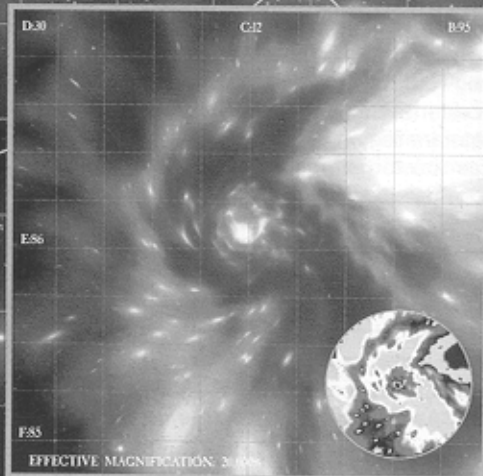

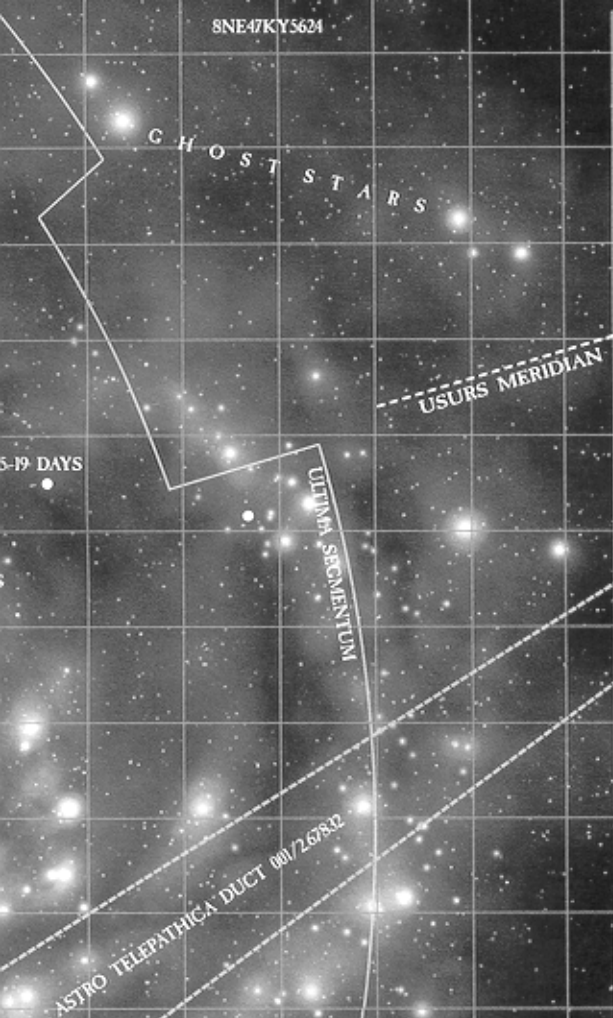

and henceforth be it known that the Imperium shall be divided into five fleet zones to be known as the Segmentae Majoris. These shall each have a Segment Fortress, from whence the orders of his glorious magnificence, the Emperor, shall be issued. Command Decrees shall be issued and with just duty be issued over the Segmentae within their boundaries. For the Segmentum Solar, this shall be Mars, World of the Adeptus Mechanicus and this Segment shall extend about Mars Beneficent Emperor's Imperium. In the north of our most majestic domains shall be the Segmentum Obscurus, being in fieldom to the world of Cypra Mundi. To the South it shall make Segmentum Tempestus, with overlordship residing with the planetary estates of the hereditary Bakka.

To the West shall be the Segmentum Pacificus, under the auspices of the Lords of Hydraphur. The most turbulent East, a region of much strife and dissension, and of many lost

Ultima Segmentum, and its guarantor of safety shall be on the planetary Governor Kar Duniash. The Segment Fortress Imperial official of the Administratum known as the Master of the Segmentum Solar.

Region of the Segmentum Pacificus, and the Master of the Ultima Segmentum. In the Emperor's Imperium. Thus shall the Emperor's charges be authority over such domains and shall reside with those who have the faith and temperament to dictate to the will of those others and

PLANET SYSTEM DEL-3
ASTARTES REGION, 5645KF
QUAD: 637/7456

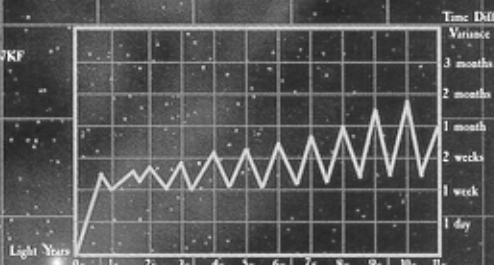

Y89

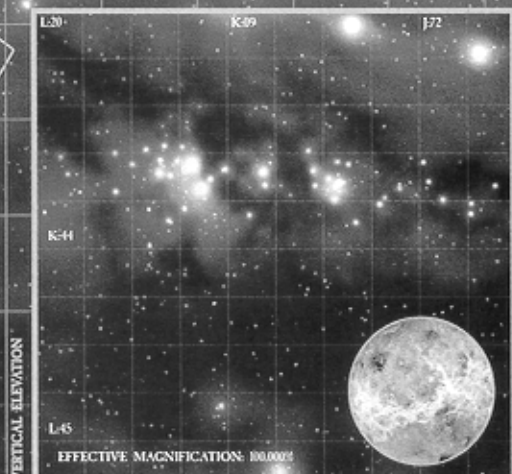

ECHO 4732JYM BETA
INITIATE RECON

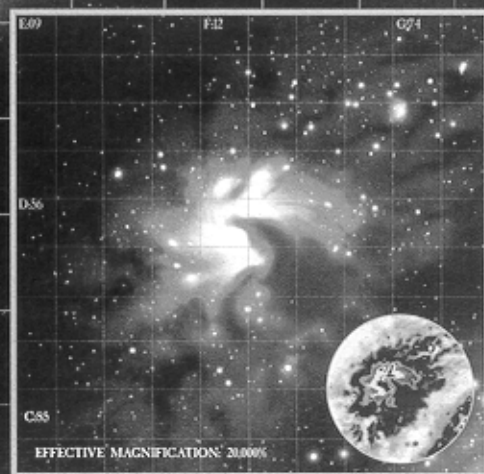

BETA 2 QUADRANT 1:6.7DY
FORESTALL RECON

THE IMPERIUM



The vast size of the Imperium makes a mockery of any true form of governance above that of the

Imperial Commanders. These individuals are appointed by the Adeptus Terra to rule over a world or worlds in the Emperor's name. They are bound to co-operate with other servants of the Emperor and to control mutations and heresy in their domains, but on the whole they are free to implement Imperial Law in any way they see fit or necessary.

Above and beyond these planetary governors, vast organisations attempt to hold back the seething anarchy that constantly threatens to engulf the Imperium. The innumerable clerks, scribes, logisters and archivists of the Administratum attempt to instil some form of order to this haphazard empire, recording, requesting and analysing a torrent of

information from the furthest corners of the galaxy.

Imperial Guard regiments, each numbering tens of thousands of soldiers and tanks, are raised and transported to distant war zones every day, their efforts supported by the millions of quartermasters and logisticians of the Departmento Munitorum. The Space Marines of the Adeptus Astartes send forth their elite warriors to do battle with alien monstrosities and treacherous humans, pursuing their wars and expanding their dominions in the name of the Emperor. The ancient Adeptus Mechanicus sends forth its Explorator fleets to investigate and explore, uncovering ancient technologies for their masters on Mars to study and decipher.

The Tech-Priests continue the search the began long before the Emperor ascended to power and began the Great Crusade of Reconquest. The religious leaders of the Ministorum of Earth, or Ecclesiarchy as it is more widely known, preach the Imperial Creed of fervent faith to the Emperor and unswerving sacrifice to humanity and the Imperium. Their Missionaries and Battle Sisters bring the light of the Emperor to worlds unheard of by mankind for countless millennia, while the zealous Confessors stir up devout citizens to cast out the heretic and unbeliever, leading witch hunts through overcrowded hive cities and across barren wastelands.

This seemingly haphazard morass of wars and politics, faith and retribution is bound together by loyalty to the Emperor and the common goal of racial survival. Complex agreements of trade and protection bring these organisations to common ground, ancient loyalties and debts are exchanged for favours and goods. While the competition for power is strong, no one world or organisation within the Imperium can truly stand on its own against the horrors that threaten humanity. Despite the intrigue and double-dealing, the clamouring for resources and the endless wars and battles to be fought, mankind struggles on through history on some predestined course towards destruction or greatness.

No reliable records concerning the rise of the Emperor to power and the Imperium's creation have survived the ten long millennia since the Great Crusade. However, by scouring the sources at our disposal and gleaning information from myths and legends we can begin to hypothesise what happened in those momentous times.

The ascent of the Emperor marked the end of inter-human warfare and galactic decline – the remote time we now call the Age of Strife. Before the Age of Strife, humanity's physical power waxed, but at the cost of man's spiritual strength. During this period, the even more distant Dark Age of Technology, the human race sold its souls to the glory of technology, forgetting their own magnificence in favour of the accomplishments of so-called science. Through the mechanical, biological and alchemical madness of the Dark Age of Technology, which brought about the decline during the Age of Strife, mankind has come to the present age: a glorious age of conquest, when men's hearts will rule the stars, not their machines. What secrets the Tech-Priests of Mars uncover from the distant past will no longer rule our lives. We will harness the technology we find, and not become slaves to it as we once were. Through human endeavour, and honest blood, sweat and toil, mankind will rule the galaxy with the grace of the Emperor and finally attain our rightful place as Lords of the Stars. We are in the great times of the Age of the Imperium, the realm of the Beneficent Emperor.

The Emperor is an eternal part of the universe, at one with and ruler of the stars themselves. The Emperor and the Imperium are one and the same, and no mortal man can now recall a time without either.

The Emperor Magnificent is the greatest and only god – it is his awesome mind that broadcasts the Astronomicon, that guides spacecraft through the warp and to their distant destinations. Without the Emperor there would be no Astronomicon, no long range space travel, no galaxy-spanning Imperium – No Humanity. Without the Emperor we are nothing.

In his divine wisdom, the Emperor has ascended to a higher plane and no longer moves or talks, even his ability to communicate psychically is limited, such is his power and our own mental inadequacies. The holy task of interpreting the Emperor's judgement and dictates for humanity is the sacred duty of the Most Favoured Men – the High Lords of Terra, the Senatorum Imperialis. From them, the multitudinous devout Servants of the Emperor can be given rightful guidance.

Introduction from Liber Doctrinae Historicus

THE EMPEROR



"The strength of the Emperor is Humanity, and the strength of Humanity is the Emperor. If one turns from the other we shall all become the Lost and the Damned."

The Sermons of Sebastian Thor,
Vol. XXVII, Ch. LXII

Mankind's protection by the Emperor is not without sacrifice, he does not survive on praise alone. At the very founding of the Imperium, as the Emperor and his Space Marine legions brought order to the anarchy left after the Age of Strife, a treachery of the most loathsome kind was perpetrated. The Emperor's most trusted commander, Horus, turned his back on the teachings of the Emperor and embraced the power offered by the dark gods that strive to enslave mankind.

Terror and death reigned, as the Imperium was torn apart by internecine war. Worlds were ravaged, whole armies slaughtered, and the forces of Horus advanced upon Terra until the Imperium was on the verge of defeat. At the very last, the Emperor destroyed the traitorous Warmaster in single combat, but was himself left mortally injured.

To sustain the Emperor's shattered body a great device called the Golden Throne was devised and

built. Using arcane techniques and machines whose function have long passed from true understanding, the Golden Throne fulfils its grim purpose. The Golden Throne is unique in the way it fuels the Emperor's needs, for the Emperor cannot eat as a man eats, or drink fluids or breathe air. His life has passed the point where such mortal things can sustain him.

For the Emperor the only viable sustenance is human life force – souls – and he has a great and insatiable appetite. Nor will just any human suffice for this purpose, for the soul-donor must be a very special person in their own right, someone with psychic powers. Sacrificed into the bizarre and archaic machinery of the Golden Throne, their life essence is slowly, agonisingly, leached from their body to feed the Master of Mankind. Every day, hundreds must be consecrated to the Emperor in this dire manner if he, and therefore the Imperium and humanity, are to survive.

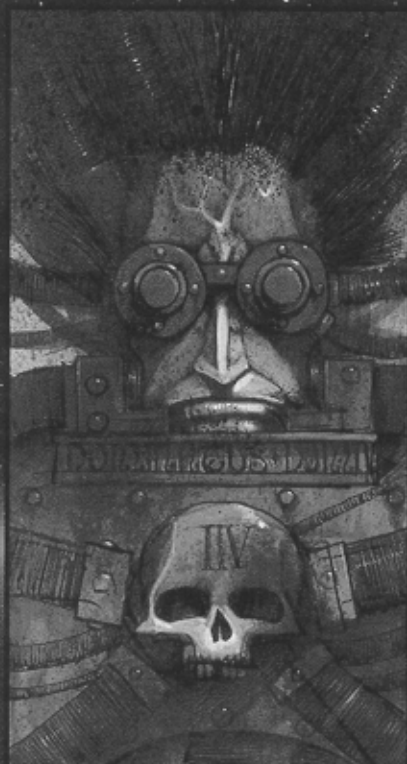

"Listen not to the alien, look not upon the alien, speak not unto the alien!"

THE IMPERIUM OF MAN



THE HIGH LORDS OF TERRA

May the Emperor be one with their hearts



The **HIGH LORDS OF TERRA** form the supreme council of twelve of the most powerful men of the great galaxy of mankind. It is they who rule the Imperium in the name of the beneficent Emperor of humanity.

THE ADEPTUS TERRA

The great priesthood of Earth

The Adeptus Terra consists of many millions of dedicated servants whose duty is to interpret and enforce the Imperial will. The Priesthood is divided into many departments and sub-departments, some of which operate so secretly that their existence is unknown outside of their own membership.

THE MINISTORUM

For the spiritual instruction of mankind

To countless billions the Emperor is nothing less than a god. Over the aeons this faith has spawned a vast and powerful organisation devoted to his worship - the Ministorum or Ecclesiarchy.

THE ADEPTUS MECHANICUS

The lords of Mars and tech-priests of the machine god

The Tech-Priests of Mars are the guardians of ancient knowledge. Their vast orbital workshops turn out the majority of the weapons, spacecraft and other technologically sophisticated machinery used in the Imperium. The realm of the tech-priests extends to forge worlds throughout the galaxy.

THE ASTROPATHS

Their minds pierce the darkness

Astropaths or Astrotelepaths are capable of sending a telepathic message over interstellar distances. The vast distance between the stars means that technological forms of communication are useless. Only Astropaths have the power to send and receive psychic messages over interstellar distances.

THE ASTRONOMICAN

The guiding light of the Emperor

The Astronomican is the psychic homing beacon which enables Navigators to steer their ships through the warp. The raw psychic power behind the Astronomican is provided by a choir of ten thousand psykers who give their lives to their task.

THE FLEET

Our bastion amongst the stars

Without the fleet human worlds would be isolated from each other and from the protection of the Imperium. It is the fleet which welds the Imperium together and transports its warriors to battlefields across the galaxy.

THE ADMINISTRATUM

The sound of a thousand pens scratching

The Administratum is responsible for assessing and levying tithes, distributing Imperial resources, and countless other administrative functions. It is the largest of all the departments of the Adeptus Terra. Its members are for the most part scribes and petty officials, the hereditary slaves of a galaxy-spanning bureaucracy.

IMPERIAL COMMANDERS

Lords of the worlds of man

Imperial commanders are the great feudal lords of the Imperium. Their domains are entire worlds. They must maintain order carry out Imperial decrees and pay the tithes levied upon them. Most importantly they must provide troops for service in the Imperial Guard the mighty army of the Imperium.



As we of the Priesthood of Earth, the Adeptus Terra, are the right hand of the Lord so are the Inquisitors his left hand. As our numbers are billions stretched over the Earth so they are few amongst the darkness of the void. As we are seen in our robed multitudes so they move unsuspected upon dark purposes. We have our masters and they have theirs but each serves the Imperium of man as he may. Do not hinder them - for to hinder them is death deserved. Do not seek them out - for they do not welcome strangers. Do not envy them their freedom - for such freedom comes with constraints such as you cannot conceive. Fear them for they are terrible! Each has his burden of death, of the extinction of worlds, and the destruction of the weak. A billion souls cleave to his conscience and haunt his sleep, crying "Why us... Why did we have to die... We innocents, we hundreds of thousands of millions of billions of dead." They are permitted no pity because pity would destroy them. I say to you, "Pity those who are the left hand of the Emperor for they cannot pity, as we weep tears for the Emperor who has no tears to shed for his own eternal agony."

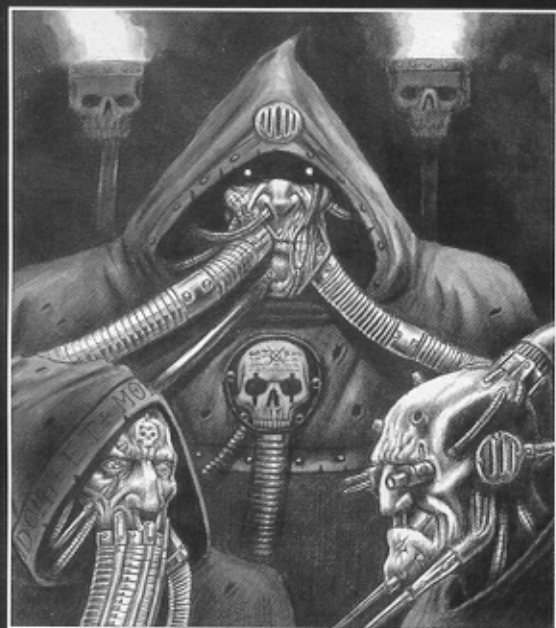

Every servant has his place, no matter lowly or modest. To know it is his greatest comfort, to excel within his greatest solace, and his master's contentment is his greatest reward.

Codex Administratum

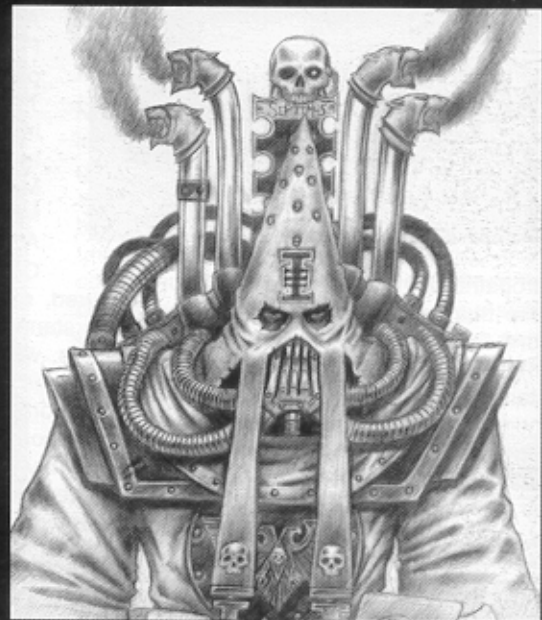
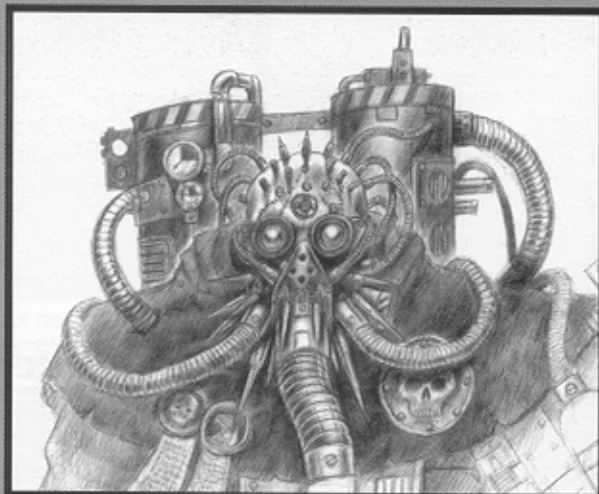

The rewards of tolerance are treachery and betrayal.

No army is big enough to conquer the galaxy.
But faith alone can overturn the universe.

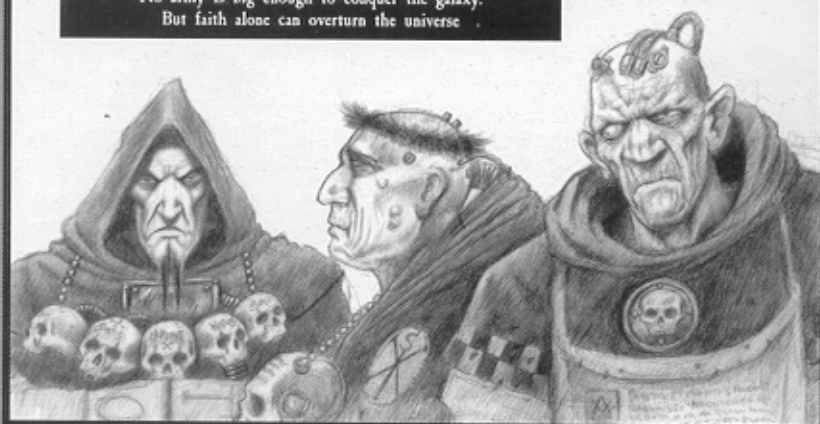

A man may die yet still endure if his work enters the greater work, for time is carried upon a current of forgotten deeds, and events of great moment are but the culmination of a single carefully placed thought. As all men must thank progenitors obscured by the past, so must we endure the present so that those who follow may continue the endeavour.

The Chime of Eons
Garbo Mojaro

Technomagos of the Adeptus Mechanicus

ASTROPATHS



Astropaths are extremely important within human society because they afford the only means of communicating over interstellar distances. Astropaths are capable of sending telepathic messages across space and they can receive messages sent by other Astropaths if their minds are correctly attuned.

Telepathic messages travel through the warp and so travel faster than light, although they are not instantaneous.

The need for Astropaths is enormous. They are a common sight in the Imperium and are easily distinguished by their flowing, hooded robes. They do not mingle with ordinary men except when duty dictates, and the privacy of their sanctums on worlds and aboard ships are sacrosanct areas made inviolable by Imperial law. Astropaths serve in the Fleet as ship-board and planetary communicators. They also serve in the Imperial Guard, the Inquisition, the Adeptus Ministorum, the Space Marines and throughout the Adeptus Administratum.

Confidentiality can still be assured, as an Astropath need not understand a message to transmit it. In this way, with various secret languages, codes and ciphers, covert orders and other sensitive information can be passed across the galaxy without anyone other than the intended recipient understanding its contents.

The Imperial Commanders of distant worlds must have Astropaths if they are to communicate with the rest of the Imperium. Similarly, Astropaths are an essential part of civilian life, working for commercial shippers and anywhere where interstellar communication is needed. The vast body of the Adeptus Astra Telepathica makes up a network covering almost the entire Imperium, facilitating the transfer of information from one end of the galaxy to the other. Although the range of a single Astropath is not vast, only several light years, by means of re-broadcasting a message via a relay of other Astropaths, a communication can theoretically be sent from one corner of the Imperium to the farthest flung reaches.

However, as with everything associated with the warp, astrotelepathy is an erratic process. Like the Astronomican, an astropathic message is affected by the currents and storms of the warp. Messages may take days or weeks to traverse the distance or even wander off course and be picked up by the wrong receiving Astropath. It has been known for messages to be delayed by many years, even decades, so that a plea for help or a report of a war may only come to light long after any aid would be useful or a campaign has been lost.



THE SOUL BINDING

No ordinary psyker could transmit a message through the warp, nor could he receive a telepathic message over such vast distances. Astropaths only gain this ability as a result of their many years training, culminating in a special ritual which combines some of the Emperor's own power with their own. This ritual, known as Soul Binding, brings the mind of the psyker close to the psychic greatness of the Emperor. In the process, some of the Emperor's vast energy is transferred to the Astropath.

The transference of energy is traumatic for the psyker - not all survive despite years of preparation, and not all those that survive retain their sanity. Even the survivors suffer damage to the sensitive nerves of the eyes, so that almost all Astropaths are blind. In fact their increased psychic skills tend to make up for this loss of sight, so that they would not appear blind were it not for their distorted, sunken and empty eye sockets.

THE INQUISITION

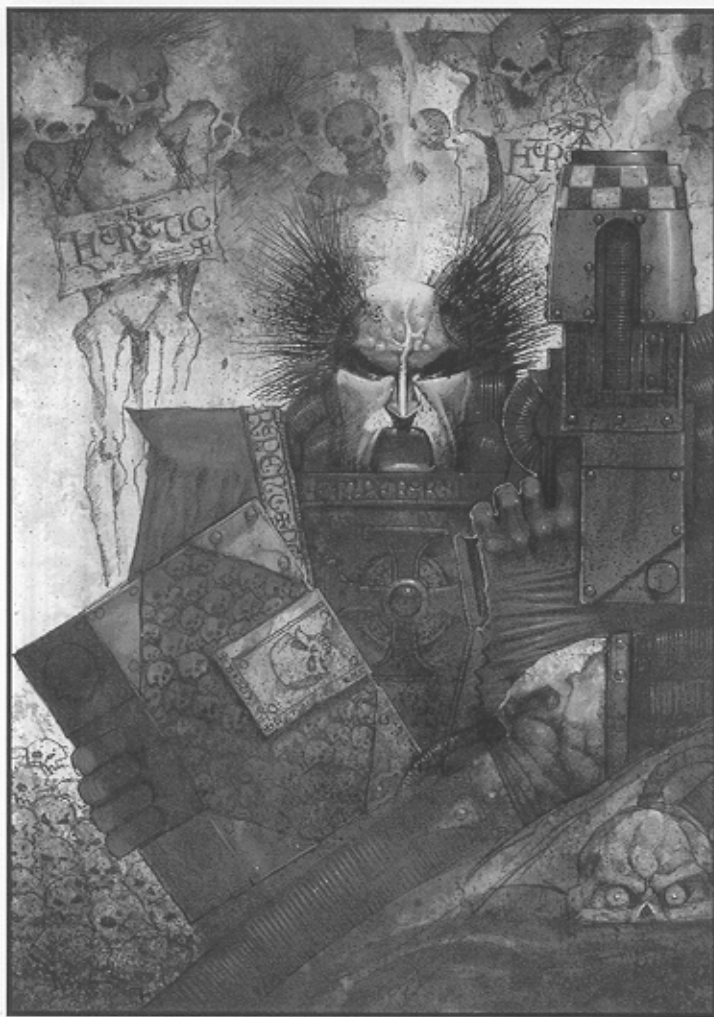

The Inquisition is one of the most widely known organisations of the Imperium. Its mandate is to investigate and stop any threat to the Imperium and mankind, and it will use whatever means it must to ensure this goal is met. Individual Inquisitors are free-roaming trouble-shooters bound by no laws or authority. There are no bounds to the Inquisitor's field of operation – alien plots, administrative inefficiency, corruption, mutations, crime, secret cults, heresy, unauthorised psychic activities all come under his jurisdiction.

Inquisitors can act alone but more often than not they are accompanied by an entourage of retainers and warriors who have been requisitioned to help them with the task at hand. Any of the Imperium's many fighting forces may be pressed into the service of an Inquisitor, the greater the perceived threat to humanity the greater are the forces gathered to fight it.

No world, no organisation, no individual, is immune to the Inquisition's gaze: planetary governors, even the High Lords themselves, are subject to investigation and no treachery or betrayal of the Emperor is too petty to be left unpunished. However, it is the psyker that commands the majority of an Inquisitor's time. Untrained or deviant psykers represent a terrible threat to humanity and it is the pursuit of these that has earned the Inquisitor the name of witch-hunter across the galaxy.

The ends always justify the means.

On occasion it may be that the Inquisitor comes across a situation that is so prevalent and widespread that there is no possibility of solution or redemption. Such situations could include planet-wide collusion and support for a heretical individual or organisation, where the removal of the individual or organisation would only strengthen the subversive cause they preach. Intervention by aliens may grow to such an extent that it brings a large segment of a population beyond salvation.

Worship of dark and proscribed powers can also spread in this alarming manner, either overtly or covertly, holding sway

over the populace of a world or worlds. Also, it is a proven theory that an aggressive response to certain threats can serve as a powerful example to those in contact with a subversive world, discouraging others of a heretical leaning from contemplating their treacherous designs.

In these situations there can be only one recourse – Exterminatus – the eradication of all life on a planet. Although Exterminatus should only be used in the most extreme of cases and should never be undertaken lightly, you must harden your soul to the possibility that the innocent may fall alongside the guilty. It is better that a thousand innocents suffer

death than a single guilty man be free to spread his heresy, and strength of will must be practiced in all that you do. A moment of personal weakness could be the first step leading to the downfall of the Imperium and the ultimate survival of mankind which we strive for.

Although billions of lives may be lost during Exterminatus, such is the threat posed that countless billions more are saved in the long term. There is no place for the weak-willed or hesitant, only by firm action and resolute faith will mankind survive. No sacrifice is too great, no treachery too small."

Extract – Liber Doctrina Ordo Hereticus, Chap XXVIII 'Exterminatus'

THE SPACE MARINES



"There is less than one Space Marine for each world of the Imperium. Nevertheless they are number enough for the task in hand."

Created by the Emperor himself at the dawn of the Age of the Imperium, the Space Marines of the Adeptus Astartes helped forge the Imperium from the scattered remains of humanity left after the Age of Strife. A Space Marine is the most powerful and most dreaded of all the Imperium's warriors. In almost every respect they are not really human at all, but super human – superior in almost every way to an ordinary man.

Space Marines can live for hundreds of years. Their senses are sharper and their muscles stronger than those of a normal man. Their bodies contain organs unique to Space Marines which enable them to survive poisons, heal wounds in a matter of moments, and to see through the dark as if it were day. A Space Marine's powered armour is connected by special interfaces so that it acts as a thick armoured skin – moving as they move, reacting as a living component.

As well as this physical transformation, the Space

"The Adeptus Astartes is not a subtle instrument to be delicately wielded like a surgeon's knife. Rather it is likened to a mighty hammer which smashes asunder that which stands in its way."

Marines are highly trained in matters martial and religious from an early age and subjected to intense hypnotherapy. All this preparation is turned towards making every Space Marine into an awesome, disciplined servant of the Imperium.

Space Marines are entrusted with all sorts of specialist and highly dangerous missions, such as lightning raids behind enemy lines, infiltration attacks to capture vital positions and tunnel fights in enemy-held cities. The human fighters of the Imperial Guard would be hard-pressed to survive against the likes of Orks, Tyranids and Eldar in these battles, but Space Marines are renowned for their ability to take on potentially suicidal odds and survive. They also undertake long voyages of planetary exploration and conquest, pushing back the borders of the Emperor's realm.

An hour before dawn the night patrol ended and the Chapter knelt to prayer. There had been no shot or shell from the Ork lines since dusk. The silence was broken only by the hiss of the open comm-line in each warrior's helmet. Chaplain Lei'land led the prayer, his rolling voice reverberating just as it did in the Chapter's Sanctorum a hundred light years distant.

"Lord we offer our lives." "Our courage and our faith," the warriors replied as one. "By our gods and the Emperor." "So be it this day!" thundered the echoing response.

It was a short prayer. A prayer for battle. The warriors rose to their feet, armoured suits humming and hydraulic lines pulsing as they took up arms. As they did so a piercing scream came from beyond the mounds of green-skinned corpses that covered the killing ground. Then a hundred more joined it and the scream became a howl, and for each new voice another hundred took up the call until the whole sky keened with the call to battle.

They came in a single mass that filled the battlefield from edge to edge. The Space Marines had borne such attacks for three days. Each day their numbers grew fewer and

fewer whilst the Ork horde seemed undiminished. Onwards ran the green tide, screaming and shooting weapons that were still far out of range. The Space Marines gripped their weapons and took careful aim. Ammunition was too scarce to waste.

The Orks reached the first mounds where their unburied dead lay ten deep where they had fallen. Their pace slowed as they stumbled on the soft decaying corpses. The Space Marines waited. The Orks scaled the piles of the slain until the red glow of their eyes stood out like burning coals in the Space Marines' vis-links.

With a crack like thunder the whole line gave fire to the Orks. More green bodies fell to the floor or exploded into a shower of dark blood and shattered bone. The line faltered. The Space Marines poured their ceaseless fire into the horde. Now a few stray shots started to strike the Space Marines, rattling off ceramite armour and striking the rocks around them. Here and there a warrior fell to the floor. Here and there an Ork reached the Space Marine lines and was cut down. But the Orks could not maintain their momentum. They fell back leaving their dead.

THE SPACE MARINE CHAPTERS

Blood Angels, Ultramarines, Silver Skulls, Dark Angels, Black Templars, Crimson Fists, Iron Hands, Space Wolves – the list of honour stretches on. There are reputed to be a thousand regiments or Chapters of Space Marines active in the Imperium, each with its own proud history, heraldry and heroes. None can be sure of the exact number of Chapters as new ones are founded over time and as old Chapters die or amalgamate. Many are extraordinarily ancient and can trace their Founding to the very dawn of the Imperium, ten thousand years in the past. The histories and legends of these great institutions are bound tightly with that of the Emperor and the Imperium and in the eyes of many are inseparable.

A Chapter of Space Marines is a complete army in its own right. Numbering a thousand men-at-arms a Chapter is quite small in comparison to the immense legions of the Imperial Guard. However, each one is a powerhouse of elite warriors able to crush an enemy force many times larger than itself. It is this fighting prowess and the indomitable will of the Space Marines that has earned them their place at the forefront of humanity's defence against the horrors that assail it.

Adept is the title of a member of the Adeptus Terra the great Priesthood of Earth. It is used as a common form of address and acknowledgement of respect – hence its adoption by the Adeptus Astartes (Space Marines) and Adeptus Mechanicus (the Tech Priests of Mars).



THE PRIESTHOOD OF MARS



The arcane technologies of the Golden Throne were built and are maintained by the Adeptus Mechanicus. Known by some as the Priesthood of Mars, the Adeptus Mechanicus design and construct many of the weapons of war used by the Imperium's armies. The research and development of technoarcana, and the uncovering and protection of ancient knowledge from the Dark Age of Technology, are the goals of the Magi of Mars and their untold billions of servants spread across the galaxy on the forge worlds. Through their mystic rites and ceremonies, intricately-phrased chants, painstakingly-prepared oils and unguents, the Tech-Priests sanctify mankind's weapons and machines of war with the blessings of the Machine God.

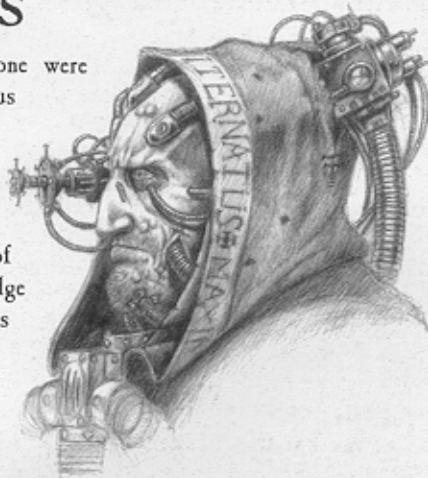

THE GOD-EMPEROR

"The Emperor is our guiding light, a beacon of hope for humanity in a galaxy of darkness. As we serve him, he is our greatest servant. As we pray to him, his thoughts are only for us. And in the dark when the shadows threaten, the Emperor is with us, in spirit and in fact."



To the innumerable billions of humanity, the Emperor is a god – the subject of mass praise and veneration. Yet it was not always so – not until the Emperor's death and incarceration in the Golden Throne did mankind turn as one to their god-incarnate. In this way, the Adeptus Ministorum grew, from superstition and saints, from disciples and prophets, into the galactic temple of the Emperor Deified – the Ministorum of Terra.

There are shrines to the Emperor on almost every Imperial world, dedicated to worship and praise of the sacrifices He makes for mankind. With countless prayers, innumerable ceremonies of adoration and homage, the Ministorum guides the mass of humanity in their devotion to the Beneficent Emperor. The history

of the Ministorum, known by most as the Ecclesiarchy, is illuminated by thousands of saints and martyrs who have dedicated their lives to spreading the Light of the Emperor to the darkness – missionaries to distant worlds, mendicants whose pious acts have served as examples to their peers, great religious leaders who have fought heresy and blasphemy and turned humanity towards the True Path of Wisdom.

Ranks of scribes and illuminators spend their entire lives copying out the sacred scripts of the Litanies of Faith, the doctrines of the Ministorum and the Rolls of Honoured Saints. Preachers and Cardinals lead their followers in fervent prayer to the Protector of Mankind, while Confessors move among the masses, persecuting unbelievers.

BY THE EMPEROR

Thou shalt attend to thy work
at the appointed hour

Thou shalt seek no reward but
the satisfaction of thy Master

Thou shalt know thy Duties

Thou shalt Obey thy Master
in all matters

Thou shalt rejoice in thy
Service

Thou shalt be grateful of thy
Master's Favour

Thou shalt not make improper
use of thy Master's comm-
links, nor his las-lines, nor his
opticon either

Thou shalt be glad of thy
Master's Punishment, for it is
deserved and it improves thee

Thou shalt not speak but
Praise of thy Master

Thou shalt not look upon the
works of the Heretic nor
speak of them

Ecclesiarchal Proscriptions
MCXVIIIV



The Mother Superior took up a pen and carefully began to take notes. To my astonishment the silver pen appeared to be studded with short pins or nails which vexed the flesh of her fingers as she wrote. Her fingers were quite raw where the skin had been worn away by the sharp points, yet she made no outward sign of discomfort as if this were the most natural thing in the world. Doubtlessly seeing my expression of horror, she stopped writing and carefully put the pen on the tabletop.

"Our belief," she said slowly, "is that there are two reasons only for a thing to be made. The first is that its manufacture inflicts suffering upon its maker which is reason enough to make it. The second is that the thing, once made, causes suffering to those who use it. It is our creed that the purpose of life is to suffer, for in this way we become one with the Emperor's eternal suffering. Have you not heard that those who suffer are blessed?"

"I have heard this and other things too," I mumbled, embarrassed by what must have appeared a morbid fascination.

"Of course. Hair-shirts! Naked vigils on cold stone floors! The scourge of prayer and endless mortifications of the flesh! She smiled as if amused by my timidity. I had heard of these things of course but could not answer her. "This pen," she said matter of factly, "was made by Sister Chastity to remind us that words have their price for there is no value in suffering for its own sake, is there?"

THE DOMINION OF MAN



The human galaxy is a complex society of countless billions of people and more than a million worlds. Although these many worlds are part of the Imperium it would be foolish to imagine that organisations such as the Adeptus Terra or the Ministorum

are able to exercise much control over their distant domains. In almost all respects worlds are self-governing, or rather they are ruled by their own governments and their own masters. The most important are known as Imperial Commanders.

Each Imperial Commander rules his planet in the Emperor's name and his world is ever at the disposal of the Imperium. Amongst the most important of his duties is that of providing regiments for the Imperial Guard. Imperial Commanders often inherit their role from noble forefathers who have ruled their worlds for generations.

Imperial Commanders are amongst the most powerful men in the galaxy. With the entire resources of a world at their disposal they can do great good for humanity... or great evil.

Despite the development of warp travel many worlds lie years or decades from their neighbours. It can take years to mobilise troops and even longer to travel to localised war-zones. Under the circumstances it is hardly surprising that some Imperial Commanders come to see themselves as above the rule of the Imperium.

Thus it is that the worlds of the Imperium are ever vulnerable to the greatest of human enemies – humanity itself. Some, lacking courage, turn to other powers, to the dark side of human destiny and the Powers of Chaos. Their folly can only lead to their eradication.

Others, their minds poisoned by greed or petty ambition, turn against their neighbours and wage war upon them. They too shall know justice.



"And the time came when a third part of the host of mankind rose up against him and waged war upon him and sought to destroy him. Then there was war in the heavens and the skies were lit with the fires of battle. There was war on Earth and the Earth trembled before the Warlord of Darkness.

And from that time there has been war between mankind and chaos – between the Imperium of Man and the Daemons of the Outerdark. It is war fought across the galaxy and upon a thousand battlefields. It is war fought in men's hearts and minds – for the corruption and subjugation of man. For the damnation of his soul and the pollution of his physical body.

And what of the damned themselves – they who forsook us centuries ago? The torment that their service has won them is unimaginable, eternal, and enduring. Vile they are, abhorrent of form, filled with foul ichors that ooze from lascivious orifices upon scaly mutant flesh, cursed with betentacled and many jointed limbs that writhe and thrash and fondle, and a thousand further such abominations of form that offend the pure and noble eye of man.

Such are the rewards of conceit and inquiry. Such is the curse that awaits ye that love not the Master of Mankind or, perhaps, love too much thine own life. Chaos waits for the faithless and the curious, those that doubt my words and those that sneer, those who know not pride nor fear not the shame of charity. Chaos waits for your soul."



WORLDS OF THE IMPERIUM

Cross ref. The Galaxy: Imperium Files 302-553
034.567.47 ref. 245.3, cross Xeno-Folders, ex.880

The worlds of the galaxy, and most notably of the Imperium, can be categorised into several broad classifications. The following list is for cursory details only, and a greater depth of detail can be found by reference to the relevant Appendices (from XVIII through XXXII inclusive) and each classification below contains examples of such designated planets which can be used for a strategic analysis of specific political, economic and cultural phenomena and trends of that category which can be extrapolated to cover most instances of that planetary type.

IMPERIAL RECORD 0034.567.87 ref. 20188

ADMINISTRATUM TUTORIAL:
Cartographer-Xenologist Seth Bartomelos,
Station 9244, Altair VII.



γ -class [Civilised Worlds]

Population: $\leq 10,000,000,000$
 $\geq 15,000,000$

Tithe Grade: Solutio Extremis
- Exactis Tertius

Aggregate: 3,500:

Aestimare: A50-F1000

Comments: This is the widest category comprising any world, generally self-sufficient, with a contemporary technology-base that does not comply with other specification. Includes major sub-categories Cardinal Worlds [cc], Garden Worlds [cg], Mining Worlds [cm].

Cross-reference: Desedna, Espandor, Korsk II, Luxor, Rhanda, Tallarn.



α -class [Agri Worlds]

Population: $\leq 1,000,000$ $\geq 15,000$

Tithe Grade: Exactis Prima -
Exactis Particular

Aggregate: 2,000:

Aestimare: C500-B50

Comments: No less than 850 parts per 1,000 given over to the cultivation of crop, hydroponics, animal fodder or animal husbandry. Few conurbations, population spread widely across planet surface.

Cross-reference: Bellis XIV, Chiros, Kabaal II, Silvanos II, Verdian III.



η -class [Hive Worlds]

Population: $\leq 500,000,000,000$ \geq
100,000,000,000

Tithe Grade: Decuma Particular-
Exactis Extremis

Aggregate: 1,400:

Aestimare: B50-E400

Comments: Surface generally inhospitable, even deadly, to human life after centuries of processing. Urban

conglomerations called Hives, many miles in height, are principle population centres. Factory, mining and atmosphere processing are main industries. High import/export ratio, particularly foodstuffs and fresh water incoming.

Cross-reference: Armageddon, Avellorn, Ichar IV, Kado, Lastrati, Mordia, Necromunda, Vanaheim.



$\phi\lambda$ -class [Feral Worlds]

Population: $\leq 5,000,000$ \geq
100,000

Tithe Grade: Solutio Tertius

Aggregate: 800:

Aestimare: F400-G800

Comments: Technical base considerably pre-black powder, even pre-ferrous or lithic state in most regressed cases. Sometimes good source of army and Adeptus Astartes recruits if culture shock survived. Low tithe due to unfocussed production processes. Imperial Commanders often distant, in orbit usually, with infrequent surface forays to establish purges of psychic talent and mutation.

Cross-reference: Belami, Davin, Fenris, Forman C2, Kimmeria, Oran.



δ -class [Dead Worlds]

Population: ≤ 1
[exc. Imperial facilities]

Tithe Grade: Aptus Non

Aggregate: 200:

Aestimare: G500-G1000

Comments: These worlds have minimal, even non-existent, life traces. This results from ecological catastrophe, devastating interecine war, Imperial or alien intervention or no attributable cause.

Cross-reference: Istvaan III, Naogeddon, Prandium, Truan IX, Zhoros.



$\delta\tau$ -class [Death Worlds]

Population:
 $\leq 15,000,000 \geq 1,000$

Tithe Grade: Solutio Tertius -
Solutio Prima

Aggregate: 600:

Aestimare: D500-G50

Comments: Planets which are too dangerous to support widespread human settlement. Types vary from world-wide jungles that harbour carnivorous plants and animals to barren rockscapes strewn with volcanoes and wracked by ion storms. These worlds are near-impossible to colonise but must be properly explored which necessitates the provision of outposts and other facilities. Some harbour rich mineral, vegetable, animal or gaseous resources.

Cross-reference: Canak, Catachan, Lost Hope, Miral, Piscina V.



ρ -class [Research stations]

Population: $\leq 500,000 \geq 100$

Tithe Grade: Aptus Non

Aggregate: 100:

Aestimare: A760-D45

Comments: Includes wide variety of locations, such as orbital stations, asteroidal emplacements and other major facilities of dead worlds, death worlds or on other planets. Responsible for wide variety of research, from animal breeding and domestication to weapons testing and geneengineering. Also listening and watch posts for planetary and system defence of major planets [Aest. B200 or greater].

Cross-reference: A1709, Arx, Fornoth, Lucan, Purgatory, Sentinel V, Ymgarl."



Warp travel is only possible thanks to the existence of mutant navigators able to see and guide ships through the psychic medium of the warp. Whilst craft travel through a sea of daemonic power they are constantly assailed by nightmarish forms given reality by the minds of the crew. Ships are protected from intrusive daemons by a psychic bubble or Geller Field which bends space around the ship enclosing it in a shield of sub-reality.

μ -class [Feudal Worlds]

Population: $\leq 500,000,000 \geq 10,000,000$

Tithe Grade: Solutio Prima-
Solutio Extremis

Aggregate: 400:

Aestimare: C750-F1000

Comments: Technical base just prior or just post-black powder state. Establishment of wide surface cultural and political organisations. Some useful recruiting for Imperial Guard and Adeptus Astartes. Slightly higher tithes than feral worlds, compensating for wider farming and animal husbandry.

Cross-ref: Atilla, Boras Minor, Chbal, Molov, Solstice, Yamnan.



ϕ -class [Forge Worlds]

Population: $\leq 15,000,000,000 \geq 1,000,000$

Tithe Grade: Aptus Non. See
files Ref: Trade Pacts, AdMech
1/0027-16/5244

Aggregate: 1,000:

Aestimare: A1-C500

Comments: Sovereign Domains of the Adeptus Mechanicus, these are planet-wide factories. A forge world often also serves as a base of operations for one of the Titan Legions. Forge worlds are essential for the supply of arms and armour to the Imperium's combat forces.

Cross-reference: Esteban VII, Gryphon IV, Lucius, Mars, Ryza, Triplex Phall.



The whole population of Earth belongs to the unimaginably vast and complex bureaucracy of the Adeptus Terra or Priesthood of Earth. The divisions and departments of the Priesthood number hundreds of thousands of independent, quasi-independent, federal, and subsidiary offices. Entire lives are spent in ceaseless shuffling of paper and checking of rosters, the assessment of planets for tithes and counting of holo-clips. Together these billions of petty and largely aimless activities turn the wheel of the tireless engine of government. All intelligent self-awareness vanished from the process millennia ago. Whole departments exist to serve worlds or agencies that have long since disappeared. Applications and petitions arrive daily from citizens and are duly processed and acted upon, though the process takes several lifetimes to complete so the citizens in question are inevitably dead by the time their reply arrives.

Such is the nature of government in the Imperium - as devoid of malice as it is without compassion.

A Galaxy of Damnation

Yes it is true what you may have heard whispered amongst the catacombs betwixt the night and nether-night! Why not say it out loud for all to hear. Let the fools doubt and sneer, it matters not. Be proud of your humanity and keep it unsullied and blessed.

This is as my Master told it to me and now I tell it thee.

There are a billion names of damnation! A billion kinds of things that slither and slime and defile the land and sea and wind. Each thing is a kind of sin spawned by man's evil. And that man is very sinful there are many of these damned things and their power is great.

As the purpose of all things in nature is to increase so it is with the damned. They would we joined them and so they seek to overcome us. In alien forms they assault us. In sleep they come to us to spread doubt and fear amongst us. They would corrupt our hearts and see us damned too. Trust them not nor suffer them to live.

For each alien destroyed is a soul freed from eternal bondage. Each mortal alien life extinguished is a human soul raised to glory. Thus our eternal destiny is written in the blood of the alien.

With sword and spear destroy the alien. With cannon shot and gun blast smash the alien. With lasers and seering plasma scatter the alien to the stars. With tooth and fist and hammer blows, with axe and shell and poison-bombs, with virus-charge and thermal mines...
Kill them... Kill them... Kill them all!

As my Master told it me now I tell it thee that thou shalt tell others in thy turn.

Other Dangerous Aliens

"It cannot have escaped any of the Council's notice but we are still plagued by alien aggressors in the Donorian Sector (Segmentum Tempestus). These are believed to be of the same xeno-type as the invaders of Prospero Colony three decades ago! [I've included the only known holo-file of these aliens: it's the big furry thing with the claws] Why can these fell creatures not be dealt with? Why must the blood of innocent colonists continue to be spilt while we do nothing? How can we let the magnificent Palace of Caleb on Assumptus V serve as a barrack house to the festering soldiers of the K'Nib?"

Erasmus Phramtle, Prefect of Soliden, City of Pyres, Danub, 334,445.M41

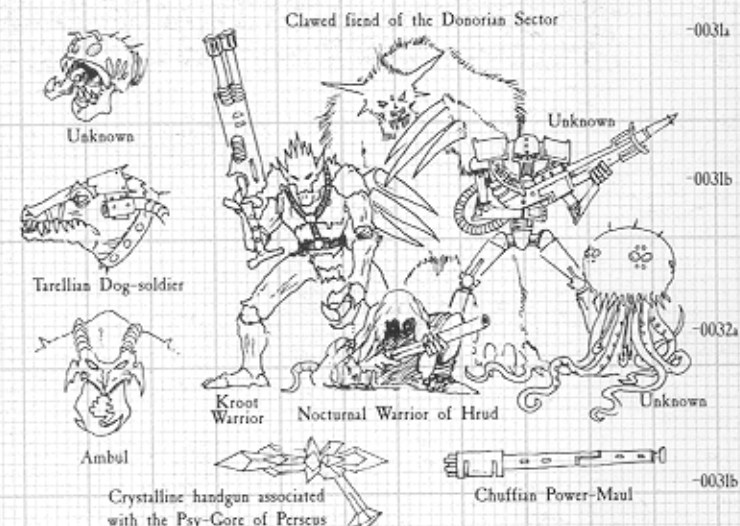

Xeno-Holofile 908.332

See sub-file 9, ref. Necros

The Eldar

Of the major alien races of the galaxy, the enigmatic Eldar are perhaps the most similar to humans in physical terms. Standing taller than the average human, the Eldar are possessed of a slim, minimal physique and delicate features. They have pallid skin, with pointed ears, flowing hair and bright, shifty eyes, and move with extreme grace, suppleness and languid decadence. Some simple-minded fools have even considered them beautiful, though the wise know not to consider an alien on their appearance alone. Inside, an Eldar's soul and motives are as alien to humanity as to any other race.

The majority of Eldar live on immense spaceships, much larger than anything any other race could construct. These artificial worlds float through space their movement erratic and contradictory at times. It is speculated that these immense vessels are capable of entering the warp and achieving faster-than-light speeds, there is no definite evidence of this. These ships pass through Imperial territories on occasion,

The Orks

As you are all no doubt aware, for generations the most consistent threat to our humble corner of the Imperium is the Orks. Spread as they are across the entire sector, in numbers rivalling that of humanity, these savage creatures know only war. From sporadic, localised raids and battles to sweeping invasions that have razed planets and killed or enslaved millions of humans, the Orks have been fighting against us on hundreds of worlds and throughout the depths of open space, especially around the Denebian asteroid belt. I have included a short quote from Hardra's Xenoptium to remind you all just what we face here.

"Orks are naturally built for bloodshed. Although usually stooped, an Ork stretched to its full height towers over a man, and Ork leaders, older and subjected to years of violence, are massive creatures able to crush a man's head with a clawed fist. Orks have a thick, leathery skin, varying from sickening green to almost black in colour, which is extremely

Tyrannids

The Tyrannids have come from a distant galaxy to consume and assimilate everything in ours. Their hive fleets are slowly invading the Imperium from the Eastern Fringe, wiping out all life in their wake. The hive fleets advance implacably across the stars, leaving nothing but extinction behind them. Though individual ships and even invasion forces can be stopped and destroyed, there are thousands of hive ships floating through the cold depths between the stars, waiting to launch their cargo of highly-evolved killing machines onto helpless worlds.

Tyrannids vary considerably in size and shape. The warriors stand about twice the height of a man, while smaller Hormagaunts, Termagants and Gargoyles spill forward around them. Hulking monsters such as the Hive Tyrants and Carnifexes rival the mighty Space Marine Dreadnoughts in size and power. All are armed with wicked barbs and claws, and a variety of symbiotic weaponry that uses biological manipulation to fire clawing, biting beetles, acidic

sometimes peacefully, sometimes their presence requiring a military response to deter them from their threatening course.

Eldar planets have also been discovered. Many of these planets are young in geological terms, in a primaeval state with lustrous jungles and chains of active volcanoes. It is possible that the Eldar themselves have created these planets, somehow transforming them from lifeless rocks. The Eldar who live in these backwaters are feral and savage in comparison to those of a space-faring nature. They evince little of the sophisticated Eldar technology, but are fierce fighters when defending their homes against the rightful colonists of the Imperium.

Then there are Eldar pirates, who appear from nowhere and attack without warning or mercy. Some hint that the Eldar's grasp of sophisticated warp technology allows them to live within the medium of warp space itself. On occasion these warrior-bands have hired themselves out as mercenaries and sell-swords, but they are treacherous and whimsical allies. They will more often attack a ship or world, enslaving hundreds, even thousands, of victims, slaughtering whole communities in a despicable display of wanton bloodshed and battle-lust.

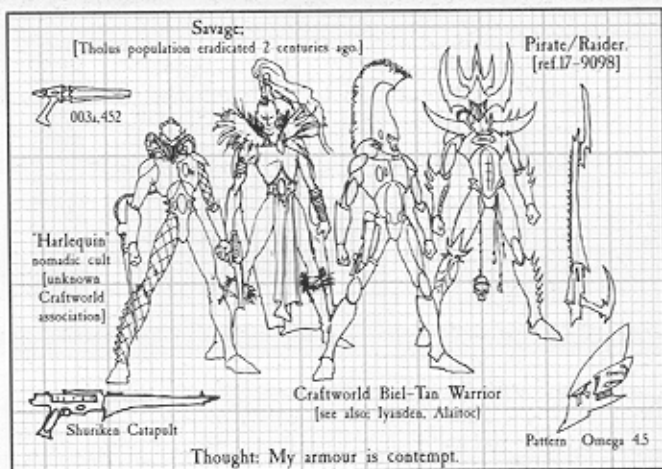

Xenobiologist Fremant, Palladium Colony

No date of entry.

Presumed to predate Prassac Razing M40.

resilient to damage. In fact, their whole physiology makes them very difficult to injure and quick to heal. Rows of fangs, up to a finger's-length, jut from their bucket jaw, and slab-like muscles move under their rough, warty skin. Their red eyes and permanent snarls give them an angry, bestial look that is altogether appropriate for their temperament. In combat they are vicious and pitiless, with a total disregard for life - theirs or their enemy's. They show little tactical or strategic sophistication, but their bloodthirsty nature, mixed with a degree of savage instinct and low cunning, make them fearsome adversaries."

My recommendation is that we dispose of these vermin as quickly as we can. If allowed to increase their numbers unchecked they will cause us untold trouble in the Sector.

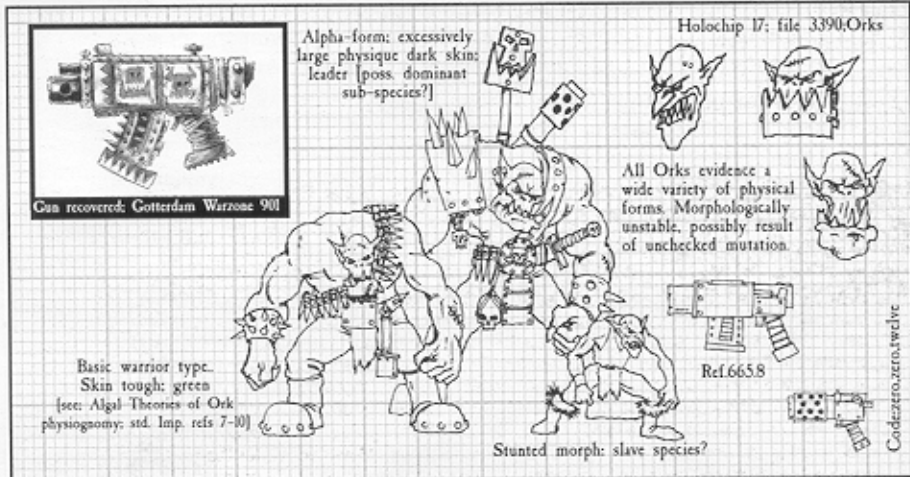

Ref. Ultima Segmentum Census 402,987

Bio./Chem./Physic.Analysis 606.445d 39177337891.M40

venom, strangling seed pods or other horrendous living ammunition (Autopsy records attached).

A vast controlling force, a kind of all-seeing overmind, pervades the Tyranid hive fleets. We call this 'the Shadow in the Warp, this 'Hive Mind' blankets all psychic powers and even nullifies the Astronomican. It is impossible to say quite how this omnipresent sense was created or is sustained, but it is surmised that it is comprised from all the consciousness of the Tyranids - a mind greater than the sum of its parts. Somehow, the hive mind can instill the needs of the Tyranids into the creatures that create it, through various 'Synapse' creatures such as Hive Tyrants and Tyranid Warriors. When these nodes of control are destroyed, the Tyranid swarms and broods degenerate into their natural instincts.

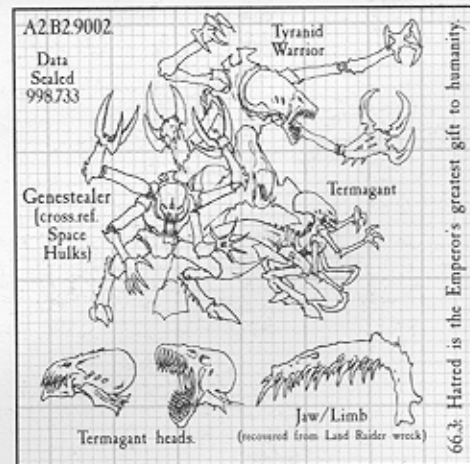
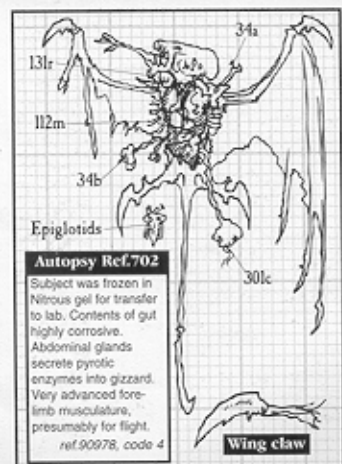

To withdraw in disgust is not cowardice.

THE ENEMY WITHIN



Despite the constant assaults by aliens and the incessant civil wars which rack the Imperium, one of the greatest threats to the long-term survival of the human race is the growing instability of the human gene-pool.

The outward expression of this is the increasing incidence of mutation amongst human populations, as if a galaxy-wide plague were sweeping across the Imperium. Many, if not most, of these mutations result in foul physical deformities or deviancies. By far the most dangerous mutants are those with psychic powers such

as premonition, telepathy and like. If not properly trained, a psyker mutant can become the unwitting pawn of the malevolent creatures of the warp. These creatures can enter real space by using the psyker as a gateway or conduit, in the process consuming the psyker body and soul!

Worse still are the psykers who actively court the attentions of warp entities and seek to establish secret cults in a misguided attempt to achieve personal power. These inevitably end in grisly failure. The Imperium has to be ever vigilant to discover and destroy these cults

before the hellish denizens of the warp can gain egress to, and overrun real space.



There is no foe more rank or malific than the traitor. We rightly abhor the traitor that leads the enemy to our gate. We revile him for the annihilation of worlds and the murder of innocents. We each loathe him for the harm that he does to us. The scars that we bear remind us to keep our hatred bitter.

What hatred have we for the traitor within? No - I mean not the traitor that hides amongst us. For it is our very flesh that is the greatest of traitors, the betrayer who corrupts and weakens us more than any other foe. It is the enemy within that we harbour unknowingly. His name is mutant, witch and deviant. He is the foe that will destroy us as no other can. He leads us before a hellish throne to dance enfeebled and imbecilic for the lewd pleasures of dark gods.

Burn the mutant and the heretic that shelters him! Burn the witch and those that worship him! Burn the deviant and those tainted by him! Let their deaths purify us so that in dying their bodies serve mankind as in life they never could.

BATTLES BOOK





We endeavour in the darkness of battle who cannot win the fight. The time for peace is over and now it is time to die. It is the age of war and our last days must be lived amidst the sound of our own destruction.



Now the great wheel of human existence turns almost full circle. From the cradle of the Earth it has turned through vast epochs of time. Once in the light of the sun it turned as civilisations rose and fell and were forgotten. In the light of the stars knowledge blossomed and withered whilst the wheel span on. Now the great wheel of human existence, almost complete, turns again as it approaches a time of dying and the moment of inhuman birth.



Abhor the Night, it is the Light that Endures!

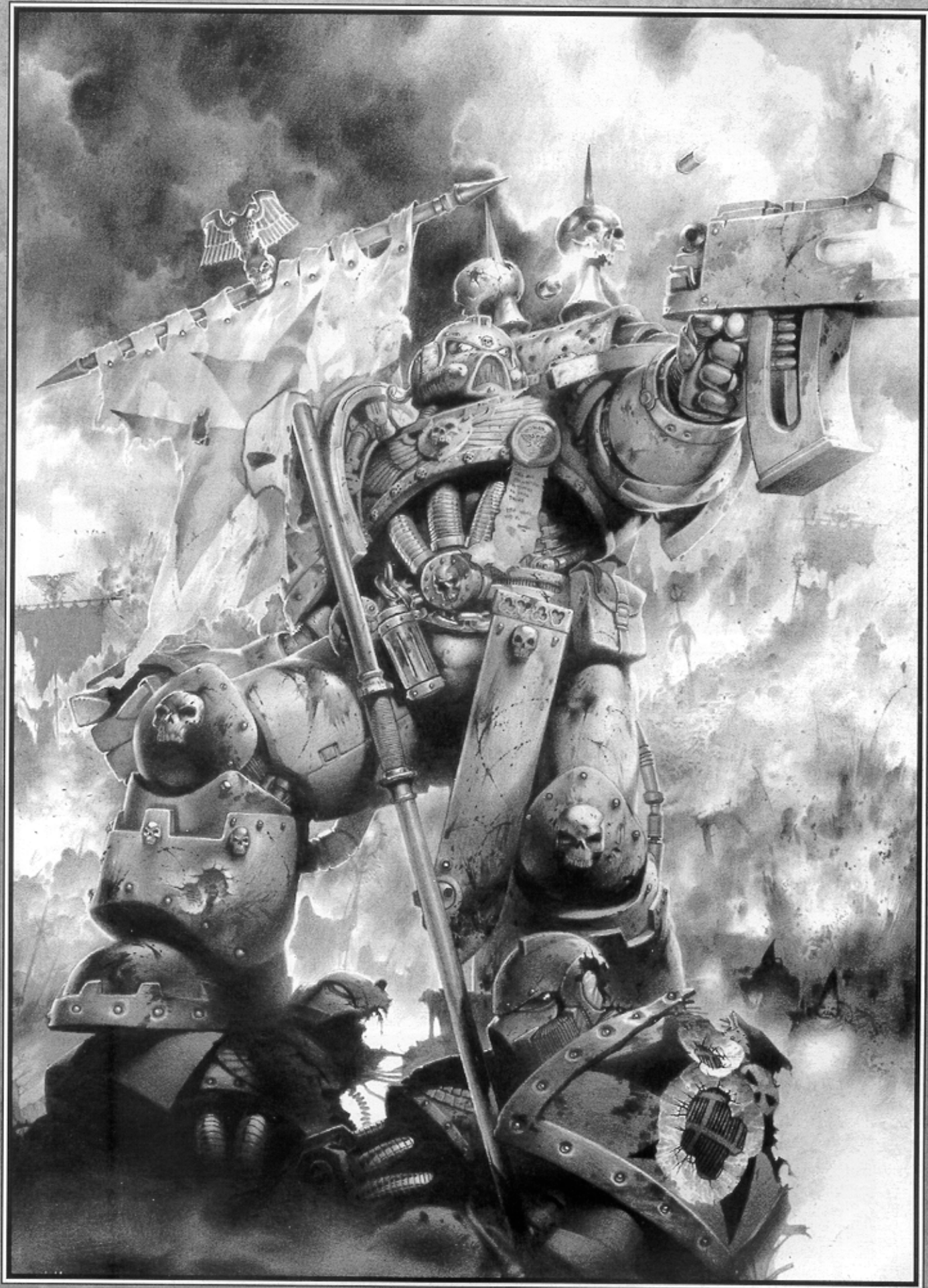

BATTLES BOOK INTRODUCTION

We've established how to go about moving and fighting with our forces in the Rules Book. In the Battles Book we're going to take a look at how to set up a battle between two opposing armies and fight it out using those rules. This includes creating the battlefield by placing terrain and scenic pieces on it, choosing armies to fight with (this also links in with the Armies Book later), different missions to attempt and victory conditions so you can work out who's won when the dust settles.

CHOOSING FORCES

A battle can be as big or as small as you like – from a simple skirmish up to a full-blown slaughterfest. You can play with all of the forces you have available or choose equally matched forces to ensure that neither side has an unfair advantage. To help in picking equally matched forces we have assigned values to units of troops, tanks, heroes and weapons in the theoretical and universal coinage of 'points'. These points values are detailed in the army lists for different races in the Armies Book. The army lists also include information on how many troops are included in each unit, what weapons they are armed with, and so on.

*The Mutant bears his heresy on the outside,
the Traitor hides it in his Soul.*

Most Warhammer 40,000 players use these army lists to organise and collect their forces as well as field them in battles. For a battle it is common practice for players to organise armies around an agreed points total of either 1,000, 1,500 or 2,000 points. As a guideline, a battle between two 1,000 point armies will take two to three hours to play, making it eminently suitable for an evening's or afternoon's gaming. A battle between two 1,500 point armies will last for most of a day, and larger games are best tackled with an eye to them taking a day and evening or a couple of days over a weekend to complete.

A word of advice is to start out with fairly small games until you have picked up the rules – it's better to start a small battle and finish it than start a mega-thrune and have to abandon it halfway through. As you gain experience you will find the time it takes to complete a game will decrease and larger and larger battles become more manageable.

SCENARIOS

The most simple and straightforward battle is where two sides line up on opposing sides of the table and battle commences, last man standing is the winner. This is the ideal kind of fight for seeing who's got the toughest army and can slug it out for longest.

However, in the 41st millennium warriors and war machines fight in all kinds of circumstances. Roving patrols clash in disputed territory, recon units try to penetrate their enemy's battle line, assault forces try to overrun defensive positions or two commanders unleash their armies in a straightforward attempt to cleanse the battlefield of their hated foes.

This is where scenarios come in. They give details of different sorts of game you can play and are used in combination with the army lists to select appropriate forces. When you arrange a game you can decide which kind of scenario to fight so that you can choose your army beforehand.



THE BATTLEFIELD

In order to fight a battle you will need somewhere to set up your battlefield – a flat, stable area unlikely to be ravaged by natural disasters like The Feet of Doom or the equally terrifying Household Pet Monster. Some people make do with a smooth bit of floor (although this is likely to fall prey to The Feet), but most use a largish kitchen or dining table (suitably protected by a cloth or blanket). By far the best option, if it's available, is to fight over a gaming board made up of sheets of chipboard, plywood or MDF laid over another table. Typically the battlefield should be between 6 to 8 feet long (around 1.8 metres to 2.4 metres) and 4 to 6 feet broad (1.2 to 1.8 metres). You can play on a smaller area quite easily, but you'll need to keep the forces fighting proportionately smaller to ensure that you've got some room to manoeuvre.

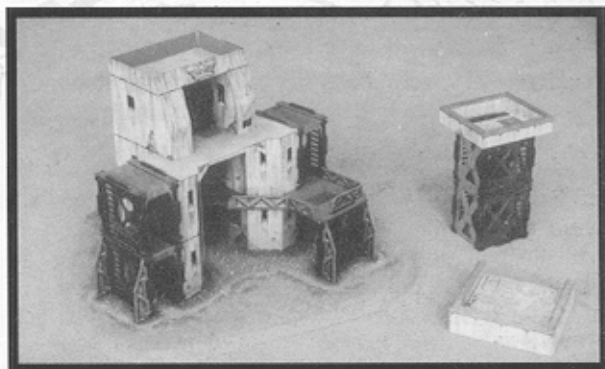

terrain piece can become the focal point of a battle, such as a bridge that must be taken or a refinery that must be destroyed.

Building up a collection of scenery is an important and enjoyable part of the hobby. It is possible to buy all kinds of terrain like trees, bushes, hedges, fences, ruins, tank traps, crates, barrels and card or plastic buildings. Take a look in your local Games Workshop store (if you have one nearby) and you'll find all kinds of scenery that you can buy as well as textured cloths for covering your tabletop and lots of other useful tools and materials. Failing that, model shops and particularly places that specialise in model railways have a good selection of scenery, although it is often comparatively expensive.

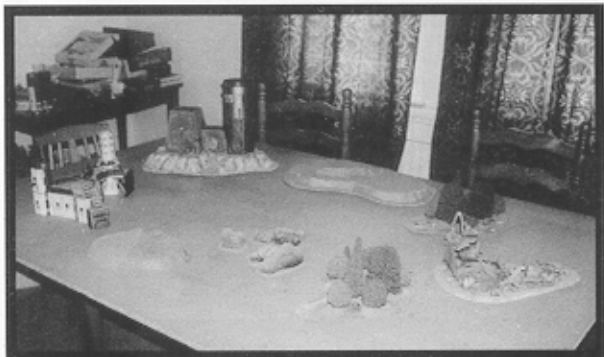

TERRAIN

So you've got your battlefield, but it's flat, featureless and devoid of life. While this might be appropriate if you're fighting over a starship landing field or deserted salt flats, it makes for a rather dull battle. Terrain is an important feature on all battlefields. A good commander will use the terrain to his best advantage, blocking the enemy's lines of fire, getting his heavy weapons into good firing positions and concealing his troops until they are ready to strike. Troops on the ground need cover and concealment if they are to survive against the deadly weaponry of the 41st millennium. A very large

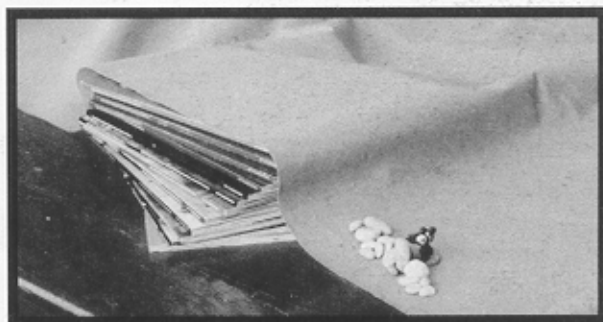

If your budget is limited, simple pieces like rocks and logs can be represented by small stones and twigs scavenged from the garden, hills can be indicated with books placed under a blanket or sheet, and so on. Beyond this there are almost limitless opportunities for making scenery easily and very cheaply. With a little effort you will soon become an expert at building hills, jungles, craters, trenchworks, bunkers, temples and all manner of terrain. The list of different types of scenery is endless; from ash wastes to ice worlds, jungles to volcanoes, all could feature on your battlefields. White Dwarf magazine often contains articles about making scenery and is a great source of ideas and inspiration.



PLACING TERRAIN ON THE BATTLEFIELD

There are many ways to set up terrain, and any method is perfectly acceptable as long as it creates a fair battlefield. The missions all advise you to set up the terrain in a mutually agreeable manner, and any of the following methods would suffice. Remember that the purpose of setting up terrain is to provide an entertaining and interesting battlefield, not to impede movement or lines of fire so much that it becomes almost impossible to actually fight the enemy. If a piece of scenery is going to be a major feature of the battle, such as a wide sulphurous river which cannot be crossed, then you need to OK this with your opponent. This sort of battlefield is perfectly fine, and might make for an enjoyable game, but you and your opponent would have to agree it beforehand. Here are some methods you might employ when setting up your battlefield.

Setting up terrain – method 1

One of the players positions all the terrain on the table. Once he has positioned the terrain his opponent can then pick which board edge to deploy from. Many of the scenarios require you to roll off for choice of table edges, but if one player has set up the terrain then it is only fair that his opponent then chooses which board edge to deploy from, as this avoids the player who set up the terrain getting an unfair advantage. This is a good method if you are playing a game at one player's house, as he can set up the terrain before his opponent arrives, allowing you to get straight on with the battle.

Setting up terrain – method 2

The players choose, or roll for, a half of the table each. They then place all the terrain in that half of the table. This is done purely by choice. Once both players are happy with the position of the terrain they roll a dice – the player with the highest score chooses his deployment zone as indicated in the mission.



Setting up terrain – method 3

The historical refight. In some scenarios you are actually re-fighting a historical battle. In this case it is likely that the battlefield will already be mapped out for you. For a historical refight all you need to do is use your own collection of terrain to represent the historical battlefield as closely as possible.

Setting up terrain – method 4

Divide the table into 24" (about 60cm) square areas. Roll a D3 for each area, this is how many pieces of terrain will be placed in that area. Roll 2D6 on a random terrain generator (see below) for each piece of terrain in each area and position that piece of terrain anywhere within the area. If you want, you may place terrain pieces on top of each other to create, for example, a hill with a wood on top of it.

RANDOM TERRAIN GENERATORS

We've included some sample terrain generators over the following pages, but it's easy enough to come up with your own customised one which includes all the terrain in your own collection. The terrain generators we've provided are really intended to be a source of inspiration – the galaxy is full of all kinds of different worlds and the following terrain generators are just a small sample of what you could do.

Random terrain generators aren't just useful for setting up games. Some gamers use them as a rough guide to focus their terrain collection, building up model forests of ice crystals, crevasses and glaciers to make up battlefields on an ice world, for example.

On the other hand, you might decide to make the terrain generator fit the collection you already have. Simply write down all the pieces of terrain you have, assign numbers to them and you have your own customised terrain generator!

Different Worlds

In the 41st millennium there are thousands of worlds where battles rage. These vary enormously in climate and geography and in the vastness of the galaxy almost anything is possible. The following pages have random terrain generators for a few possibilities, but they are really just that. If you can think of other things to add to them then do it! You might also want to try modelling terrain for something very different like:

- **A World at War:** where battles have raged for generations and all that is left are shattered ruins, trenchworks, craters, bunkers and wrecked war machines.
- **A Hive World:** with densely packed towers and walkways, silos and hab-zones. Among the buildings lie lakes of toxic goo and quicksand-like dust pools.
- **A World of Volcanoes:** with rivers and lakes of lava, and twisted spires of black rock.
- **A Mountainous World:** with precipitous crags and sheer cliffs, rope bridges, towering spires and dense pine forests.

ASH WASTES TERRAIN GENERATOR (roll 2D6)

Polluted by thousands of years of intense industry the surface of many hive worlds has become a toxic wasteland of chemicals and ash.

Ⓐ TOXIC RIVER

Toxic rivers are very dangerous and are impassable to all infantry, cavalry, bikes and vehicles. A toxic river must be placed so that it flows onto the battlefield from one table edge and out from another. It cannot spring from nowhere and cannot simply end. A toxic river cannot extend over half the length of the games table unless your opponent agrees that it may do so.

A toxic river cannot be crossed except at a bridge. However, skimmer vehicles and jump pack equipped troops can cross the river as long as they do not end their movement in it.

A toxic river must include at least one crossing point somewhere along its length. If the river extends over half the table length then it must include at least two crossing points.

Ⓑ SLUDGE STREAM OR CANAL

A sludge stream counts as difficult ground for infantry, cavalry and bikes, though the banks of the stream or canal may provide cover. Sludge streams or canals must be positioned as for a toxic river above, with the same crossing point requirements. Sludge does not count as difficult ground for vehicles.

Ⓒ SLUDGE BEDS

An area of thick sludge-covered ground no larger than 9" by 9". The sludge counts as difficult ground to infantry, bikes and cavalry, but is flat and so provides no cover. Vehicles are not affected by sludge.

Ⓓ DETRITUS

An area of detritus will include barrels, piles of junk, wrecked vehicles, pipes, spare tyres, crates and suchlike. They provide cover for troops hiding amongst them, but do not impede movement. Bikes, cavalry and vehicles count detritus as difficult ground. An area of detritus must be no larger than 12" by 12".

Ⓔ ROCKS

An area of rock-strewn ground no larger than 12" by 12". Rocks provide cover for infantry and count as difficult ground for all units. Very large rocks will be impassable to vehicles.

Ⓕ ASH DUNES

Two to three small hills formed by wind-blown ash. Moving over the soft dunes counts as difficult ground.

Ⓖ CRATERS

Craters provide cover for infantry inside them and do not impede movement. Very large craters might provide cover for vehicles but would count as difficult ground.

Ⓗ CHEM WASTES

An area of toxic or acidic chemicals no larger than 9" by 9". Moving through the chemicals is hazardous, so roll a D6 for each model that enters the area. On a roll of 1, infantry, cavalry or bike models take a Strength 4 hit, armour saves can be taken as normal. Vehicles that roll a 1 become immobilised as if they had moved into difficult ground (the tyres or tracks melt!).

Ⓙ OLD RUINS

An abandoned building or a group of several buildings (One to four is enough). These buildings could once have been anything from a shanty town to a prison block or a temple. The ruins may have up to 12" of adjoining dilapidated walls or fences.

⓫ MINE

A working or disused mine with strophead, transport tubes or rails and so on. Two to four buildings should be sufficient. The mine may have up to 12" of adjoining walls or fences.

⓬ SETTLEMENT

A complex of buildings (two to four is enough). Buildings provide excellent cover for infantry and if large enough may also provide cover for vehicles. The settlement may have up to 12" of adjoining walls or fences.



AGRI-WORLD TERRAIN GENERATOR (roll 2D6)

Many planets are little more than farming worlds where most of the surface is given over to the production of food. This produce is shipped out to feed the billions of inhabitants of the teeming hive worlds of the Imperium.

1 A DEEP RIVER OR LAKE

Choose either a deep river or a lake. A river must be placed so that it flows onto the battlefield from one table edge and out from another side. It cannot spring out from nowhere and cannot simply end. A river cannot extend over half the length of the games table unless your opponent agrees that it may do so.

A deep river cannot be crossed by vehicles except at a bridge or ford. Troops treat it as very difficult terrain so they roll 1D6 for their movement distance across it. Skimming vehicles and jump pack equipped troops can cross the river as long as they do not end their movement in it.

A deep river must include at least one crossing point. If the river extends over half the table length then it must include at least two crossing points.

A lake should not be larger than 12" square and has the same terrain effects as a deep river.

2 SHALLOW RIVER, STREAM OR IRRIGATION CANAL

Choose either a shallow river (which counts as difficult terrain) a stream or canal. Rivers, streams and canals must be positioned as for a deep river or lake above, with the same crossing points requirements.

3 CROP FIELD

A field of tall crops, which can be surrounded by a hedge or fence. Troops and vehicles moving through a crop field are subject to the difficult terrain rules. Troops inside the field count as in cover (6+ save) because it is difficult to see them. Vehicles do not count as in cover. A crop field can be of almost any size (some cover entire continents!), but 6" to 12" square is a fairly good size to use.

4 DETRITUS

An area of detritus will include barrels, piles of junk, parts from wrecked vehicles, pipes, old ammo crates, discarded machinery and so forth. They are good cover for units hiding amongst them, but do not impede infantry movement.

Bikes, cavalry and vehicles count detritus as difficult ground. Detritus should cover an area of 6" to 12" in diameter.

5 A WOOD OR PLANTATION

Woods or plantations are difficult to move through and count as difficult ground. However, units inside a wood or plantation will count as in cover. A plantation is a wood with the trees planted in straight lines, or it might be made up of more exotic plants or giant alien fungi. A wood or plantation can be of almost any size, but 6" to 9" square is a fairly good size to use.

6 A HILL OR A WOOD/PLANTATION

Choose either a wood/plantation or a hill to place on the battlefield.

7 A HILL

Hills do not usually affect movement, but they provide excellent firing positions for heavy weapons and ordnance.

8 WALLS, PIPELINES OR FENCES

Place up to 12" of continuous walls, fences, ditches, pipelines or any other linear obstacle. Obstacles can be crossed, but infantry are likely to be slowed down by them so treat them as moving through difficult terrain. Likewise, cavalry treat obstacles as difficult terrain. Whether bikes and vehicles can cross or break through them depends on the obstacle used. Most obstacles make excellent defensive positions and will provide cover, but some, like chain link fences for example, will not offer much protection though they are still difficult to cross.

9 STRUCTURE

A single building. This could be anything from a small wooden hut to a water tower, grain silo, tall apartment block or shrine. The structure might be ruined, and may have up to 6" of adjoining walls, pipelines or fences.

10 A FARM COMPLEX

A group of several buildings (two to four is enough). The complex may have up to 12" of adjoining walls, pipelines or fences.

11 A STEEP HILL

A steep hill is difficult to move over (it counts as difficult ground), and may have cliffs on one side making it impossible to move over except by jump packs or skimmer vehicles.

ICE WORLD TERRAIN GENERATOR (roll 2D6)

Most planets have a polar ice cap, but some are so far from their sun that they are locked in a permanent ice age. With a bit of imagination this chart can be used for desert worlds by swapping snow for sand.

1 GLACIER

An extremely slowly moving river of ice, rent with deep crevasses. A glacier must be placed so that it flows onto the battlefield from one table edge and out from another side. It cannot spring out from nowhere and cannot simply end. A glacier cannot extend over half the length of the games table unless your opponent agrees that it may do so.

A glacier will be covered in cracks and fissures and so counts as difficult ground and gives cover to infantry. In addition, a glacier can include up to D6 crevasses and D6 hidden crevasses (see below) along its surface.

2 FROZEN LAKE

A frozen lake could be a thick crust of ice over a body of water or it could be frozen nitrogen, methane or some other exotic substance.

A frozen lake counts as open ground to infantry, bikes and cavalry, but difficult ground to vehicles, including walkers. If a vehicle becomes immobilised in a frozen lake roll a D6 at the start of each of its turns. On a 1 the vehicle falls through the ice and is destroyed.

3 HIDDEN CREVASSE

The ice sheet is rent by a huge gash which has been covered over by newly fallen snow, making it almost invisible. The crevasse can be 6" to 18" long and 1" to 6" wide. The crevasse counts as difficult terrain and in addition you must roll a D6 for every model crossing it. On a roll of 1 they fall through the thin snow covering and are lost forever.

4 CREVASSE

The ice sheet is rent by a huge opening of unfathomable depth. The crevasse can be 6" to 18' long and 1" to 6" wide. The crevasse counts as impassable terrain.

5 FOREST

A forest of exceedingly hardy (probably coniferous type) trees. Alternatively, you could represent the same thing with an area of giant ice crystals or something similar. The forest should be around 6" to 12" in diameter.

7 HILL OR FOREST

Choose a hill or forest to place. A hill will count as difficult terrain due to the vast snow drifts which accumulate around it.

8 HILL

As mentioned above, a hill will count as difficult terrain.

9 REFINERY

A small complex of one to three buildings, preferably with interconnecting bridges or gantries. The refinery might be wrecked, and may have up to 6" of adjoining walls, pipelines or fences.

10 RESEARCH STATION

A group of several buildings (two to four is enough). The complex may have up to 12" of adjoining walls, pipelines or fences.

11 CITY ENTRANCE

A single large structure which protects the entrance to an underground city. Such entrances are often at the centre of a complex of defensive bunkers and towers.

12 BLIZZARD

Whilst a blizzard is not really a terrain feature, it is a feature of fighting on ice worlds (just as sandstorms are a feature of fighting on desert worlds). You could either have the blizzard affect the entire tabletop or advancing on from a random table edge at 12" per turn. All movement in a blizzard counts as being in difficult terrain. Accurate firing is limited to a range of 12", beyond this 6s are needed to hit regardless of the firer's Ballistic Skill.



DEATH WORLD TERRAIN GENERATOR (roll 2D6)

Death worlds are among the most dangerous planets in the galaxy. Death worlds vary a great deal, from jungles filled with voracious and homicidal wildlife to barren, rock-strewn wildernesses tortured by volcanoes, meteor strikes or ion storms. This is an example of a terrain generator for a jungle death world.

D MARSHES

Death world marshes are insanely dangerous and count as difficult terrain to all units. In addition, roll a D6 for any model which enters a marsh. On a roll of 1 it is drowned, sunk, eaten, corroded or otherwise done away with. Marshes should cover an area about 12" in diameter.

B CRUMBLE ROCK

Crumble rock looks solid, but disintegrates on contact. It counts as difficult terrain to all units and provides no cover. An area of crumble rock will be 6" to 12" square.

A THERMOTROPIC VINES

Thermotropic vines are plants which are attracted to heat sources – like creatures and vehicles. They grow extremely quickly and will smother anything which stays still for long enough. Thermotropic vines count as difficult ground to anything crossing them, but they do provide cover. If a unit ends its movement in an area of thermotropic vines it will suffer a single Strength 5 hit on a D6 roll of 4 or more. Armour saves may be taken as normal and hits on vehicles are resolved against their rear armour value. Thermotropic vines will cover an area no more than 6" square.

V VENUS MANTRAP

Venus mantrap is a catch-all name used for a variety of carnivorous, sessile plant forms which are capable of capturing and consuming human sized (or larger) creatures. Mark the location of the venus mantrap with a counter, coin or small terrain piece. Any unit which moves within 6" of a venus mantrap will suffer D6 Strength 4 hits, with no armour piercing value. Even vehicles will be attacked, resolve the attacks against the armour facing the mantrap. The venus mantrap will be impossible to attack back as it is mostly underground and very well concealed.

J JUNGLE

An area of jungle is notoriously difficult to move through so it will count as difficult ground. Units in the jungle will count as in cover. A jungle can be of almost any size, but 6" to 12" square is a fairly good size to use.

Z JUNGLE OR HILL

Choose either a jungle or a hill to place on the battlefield.

H A HILL

Place a hill on the battlefield. This will not affect movement or provide cover, but it will give a better firing position to whoever holds it.

O OVERGROWN SETTLEMENT

A settlement which has been overrun by the death world's deadly denizens. It will comprise a group of several buildings (two to four is enough) and may have up to 12" of adjoining walls or fences. All movement within the settlement counts as being in difficult terrain.

10 SPITTING CACTUS/STRANGLE VINES

Treat this as an area of jungle, but any time that a unit is moving through it and rolls a double for its movement distance the unit is attacked. The unit suffers D6 hits due to cacti spitting poisoned needles at them, vines whipping around troopers' necks and all sorts of other nastiness. Make armour saves for each model hit. Vehicles are unaffected, but have the usual chances of getting immobilised.

11 CARNIVORE LAIR

This could be a cave, something lurking in the trees or some kind of alien trapdoor spider. If a unit moves within 6" of the carnivore lair one model will be attacked and swallowed whole on a D6 roll of 4 or more, no armour save. The carnivore lair may not be attacked.

12 BOILING MUD/TAR PITS

An area of bubbling, volcanically heated mud or tar. This counts as very difficult ground (only roll 1D6 to see how far units can move through them), but they do provide cover. Vehicles will be immobilised automatically if they move into a mud or tar pit. In addition, make an armour saving throw for every model still in the pits at the end of their move. Models which fail their save are broiled alive. The mud/tar pits can be up to 12" square.

CHOOSING A SCENARIO AND MISSION

We have created four scenario types for Warhammer 40,000: Standard Missions, Battles, Raids and Breakthroughs. Each of these scenario types breaks down into a number of different missions: five in the case of the Standard Missions and three for all of the others. For example, the Battles scenario includes a Take and Hold mission, a Meat Grinder mission and a Bunker Assault mission. To start with we'd advise sticking to the Standard Missions. This is because the Battle, Raid and Breakthrough scenarios are quite challenging even for experienced gamers, and introduce extra rules to cover things like fortifications and preliminary bombardments.

The scenario to be played is chosen beforehand by mutual agreement, as is who will be the attacker and who will be the defender where this is appropriate for the scenario (this only applies to Battles, Raids and Breakthroughs). If you cannot agree on what scenario to play, or who will be the attacker and defender, then roll a dice for it, toss a coin, arm wrestle or whatever. Alternatively, you can use our cunning strategy rating system...

STRATEGY RATINGS

Some armies have much better military organisation than others, their commanders may be more skilled in strategy and tactics, or be aided by powerful psykers. Other armies may be undisciplined or simply too large and unwieldy to react quickly. To represent these differences, all the armies have a strategy rating to determine how fast they can react to enemy attacks or mount operations of their own. If you wish, you and your opponent may use your armies' strategy ratings to determine which of the scenarios to play.

Both players roll a number of dice equal to their army's strategy rating, choosing the dice with the highest score if their army has a strategy rating of more than 1. The player that scores the highest gets to choose the



scenario category. You can also use this method to decide who will attack and who will defend if you like, or simply say that the player who chose the scenario is always the attacker.

CHOOSING A MISSION

You should not know exactly which mission you will be playing when you pick your force. To choose the mission, roll a D6 on the mission table at the start of the appropriate scenario section. Make the roll after you have set up the terrain, but before you begin deploying your forces. If you and your opponent agree, you can simply choose a mission instead.

SUMMARY

- 1: Choose scenario (use strategy rating if desired).
- 2: Decide who will be attacker and who will be defender (use strategy rating if desired).
- 3: Choose your army, using the force organisation of the chosen scenario.
- 4: Randomly determine a mission to play by rolling on the appropriate scenario mission table.
- 5: Get fighting!

STRATEGY RATINGS

No. of D6

Space Marines	3
Craftworld Eldar	3
Dark Eldar	2
Chaos Space Marines	2
Sisters of Battle	1
Imperial Guard	1
Tyranids	1
Orks	1

CHOOSING FORCES

As mentioned earlier, forces are chosen by both players picking units from their army list up to a maximum points value decided beforehand. If both you and your opponent wish, you can simply choose your forces without restriction. However, this can lead to both sides simply going for the biggest guns and toughest troops without taking anything which really shows what the army should be like – imagine an Ork force with no Orks in it for example, just Dreadnoughts and warbikes. While this might be appropriate for a very special one-off mission, it isn't representative of the army in general. For this reason, different missions have what are called force organisation charts. These give you flexibility in choosing your units, but ensure that the army keeps its distinctive character. Whether or not to use the force organisations given or make up your own, is up to you to decide, but we recommend you use them unless you are inventing a special mission of your own.

If an enemy comes on in a great horde, as Orks are wont to do, then try to direct them into a narrow defile or enclosed space, such that their numbers work against them. Crowded together those at the front will impede those behind, whilst the push from the rear will prevent those at the front from retreating or finding a better path.

Tactica Imperium

USING FORCE ORGANISATION CHARTS

Before selecting an army you should refer to the force organisation chart for the scenario you are going to play. There is a different chart for Standard Missions, Battles, Raids and Breakthroughs.

The chart limits what forces are available to you. There are five categories of troop types in every army list. They

are: HQ, Elites, Troops, Fast Attack and Heavy Support. One box on the chart allows you to make one choice from the equivalent section of your army list.

Dark boxes are required troop types. You *must* make a selection from the appropriate army list section for each dark box on the force organisation chart.



STANDARD MISSIONS

COMPULSORY

1 HQ
2 Troops

OPTIONAL

1 more HQ
4 more Troops
3 Elites
3 Fast Attack
3 Heavy Support

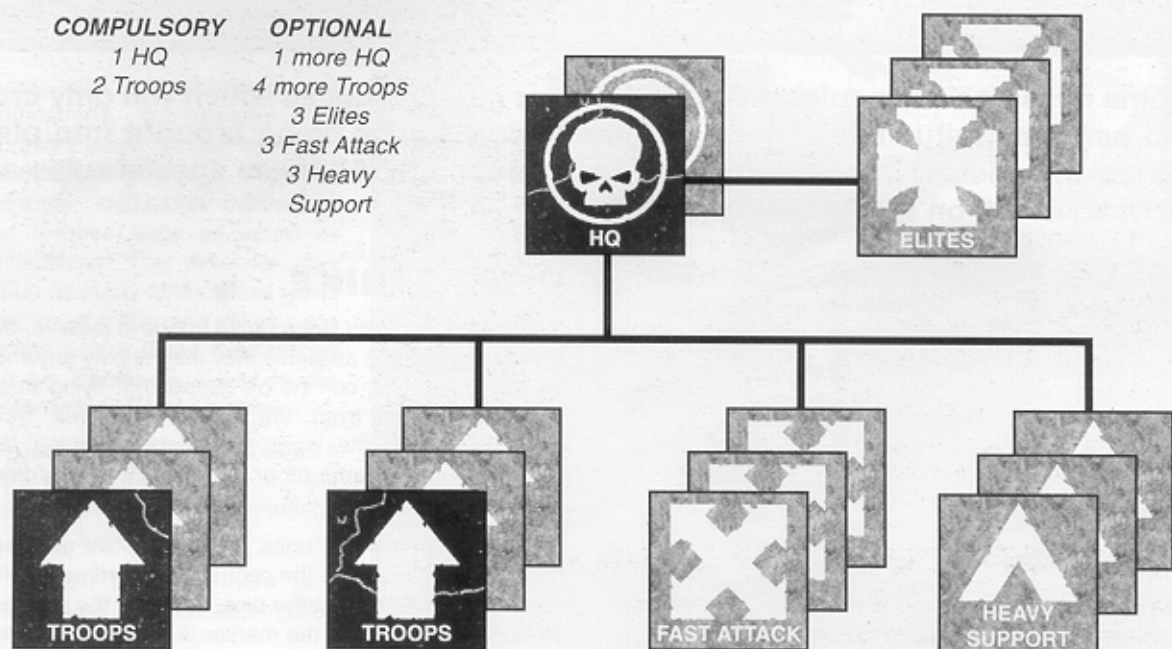

The force organisation here shows that for this mission you must take at least 1 choice from the HQ section of your army list and 2 choices from the Troops section. On top of this you can take up to 1 more HQ choice, 4 more Troops, 3 Fast Attack, 3 Heavy Support and 3 Elites.

For the most part, one box on the organisation chart is the equivalent of one unit or vehicle, but sometimes the army list will allow you to buy more than one unit for each choice. It may be that 1 Fast Attack option actually allows you to buy a squadron of 1 to 3 Attack Bikes, or in the case of the Imperial Guard, 1 choice allows you to buy a platoon consisting of more than one unit, but this still counts as one Troops choice from your army organisation.

VERY LARGE GAMES

If you're playing a large game it's helpful to understand what the force organisation charts represent. Basically the charts allow you to organise a force based on a military formation called a detachment. A detachment is a collection of units that move and fight together on the battlefield, and is the smallest formation that can be used to carry out a mission. During a campaign all the units in an army will be organised into detachments, and will tend to carry on operating in the same detachments throughout the campaign.

For example, a Space Marine company consists of over 100 Space Marines split into 10 squads, backed up by a large number of ancillary vehicles like Rhinos, Land Raiders, Predators and land speeders. Using the

company as a single force would create a huge and unwieldy formation, while ordering the squads and vehicles around on their own would be a nightmare for the company commander. Because of this, at the start of a campaign each company will be split into two or more detachments, and it is these that will be used to perform all the duties that the company is called upon to perform.

Carrying on the example above, if the Space Marines were called upon to carry out a mission they might assign a single detachment to carry it out. This would be the equivalent of playing a small game of up to about 1,500-2,000 points. For a larger mission the company might assign two or more of their detachments. This would be the equivalent of playing a higher points value game with each player being allowed to field two or more 'armies' in the same game.

So if you're playing a very big game of more than 2,000 points a side you can simply field two or more 'armies' on each side, with a separate organisation chart for each army. This is especially useful for very numerous armies like Imperial Guard or Orks which will struggle to field enough units to use all their points using a single force organisation chart.

Alternatively, you could simply double up the number of boxes available on the force organisation chart for each side, or mutually agree to increase them by a set number. There should usually be a ratio of two to three Troops boxes to each extra HQ, Elites, Fast Attack and Heavy Support box. If you want to get really wacky you could even roll for each category, adding D6-3 boxes, or a D3 to each one.

SCENARIO SPECIAL RULES

In some missions extra rules are used to cover circumstances which will only crop up in particular situations. These include reserve forces being brought into play, sentries, minefields, Deep Strike units and many more. All these special rules are described in full on the following pages.

With the single exception of Infiltrators, all scenario special rules are the same each time they are used. A general description of Infiltrators is included on the following pages, but the specific rules which apply to them in each battle can be found in the Set-up section of the relevant mission.

The scenario special rules listed in this section are:

- *Deep Strike*
- *Fortifications*
- *Hidden Set-up*
- *Infiltrators*
- *Night Fighting*
- *Obstacles*
- *Preliminary Bombardment*
- *Random Game Length*
- *Reserves*
- *Sentries*
- *Sustained Attack*
- *Victory Points*

DEEP STRIKE

If either side has any Deep Strike troops in reserve, then when they become available they may deploy anywhere on the table. This can be by teleporting, flying troops swooping down from the skies, creatures being summoned from the warp, tunnellers emerging from underground, or any other means of extraordinary movement.

To deploy Deep Strike units, choose a point anywhere on the board and place the centre of the Ordnance blast marker there. Roll a Scatter dice. On a 'hit' the marker is on target, on an arrow the marker is off target – move it 2D6" in the direction shown. Once the final position of the marker has been established, place all the Deep Striking models on top of it, facing in any direction. Deep Strike troops may not move or assault on the turn that they arrive, but they may fire as normal (though they count as having moved and so may not fire heavy weapons, etc).

If you roll a double 1 the squad has been lost – victims of a terrible accident, lost in the warp, shot down by enemy fire or crushed underground.

If the marker misses the table then the Deep Strike troops are not available for the rest of the battle.

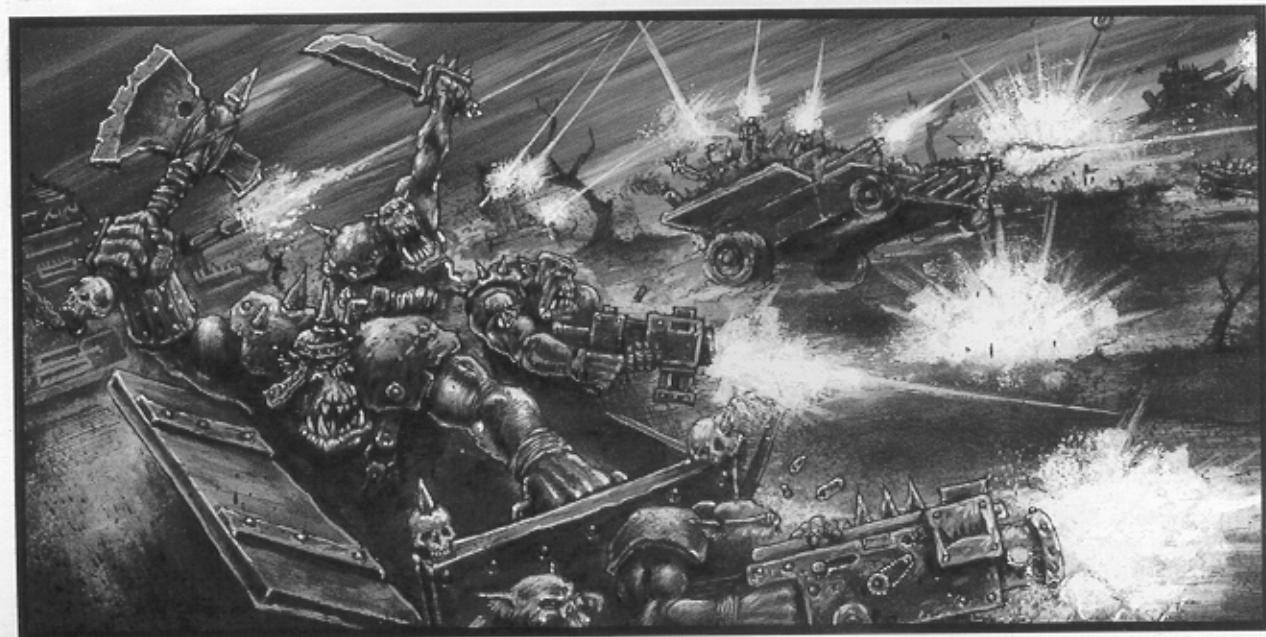

FORTIFICATIONS

In some scenarios the defender may set up fortifications. All fortifications must be represented on the board by a suitable model.

There are many forms of fortifications, but broadly they represent cover for the defender. Sandbagged positions, trenches, redoubts, makeshift barricades and fortress walls all count as fortifications. The defender may set up as many fortifications as he likes and the scenario set up rules explain where these fortifications can be placed – usually in the defender's deployment zone.

A model in fortifications receives a cover saving throw of 4+, see the Rules Book for more information on cover saving throws.

In addition to cover there is a special type of fortification called bunkers.



Adamantium walls and plasteel bulkheads may seem formidable, but an unshakable faith in the Immortal Emperor of Man can overcome any barriers.

Bunkers

Bunkers are treated exactly like an immobile vehicle with an Armour Value of 13 all round when shot at or assaulted. Troops inside a bunker may shoot as if they were being transported in a vehicle, ie half of them may fire and they may not be targeted separately. However, troops on top of the bunker do count as a separate target from the bunker although they will usually be able to hide behind a wall or parapet (getting a 4+ cover save).

Flamers Against Bunkers. Flamers may be fired against models on the roof or against the bunker itself. Resolve the flamer attack as normal versus models on the roof. If the bunker is chosen as a target the flamer does not need to roll to penetrate a bunker, instead every model inside it is hit by the attack. Roll to wound and make armour saves as normal. The bunker itself will be unaffected by a flamer attack.

BUNKER GLANCING HITS

(S+D6 ROLL EQUALS ARMOUR VALUE)

1-2 **Occupants Shaken.** The occupants of the bunker are shaken by the explosion. Troops in and on the bunker may not fire next turn, but they may still move.

3-4 **Occupants Stunned.** Troops in and on the bunker may not move or fire next turn.

5 **Damage.** The bunker is damaged. Add +1 to all future rolls on the bunker damage tables. This +1 is cumulative, so another 'Damage' result would mean +2 on the next roll.

6 **Collapse.** The bunker comes crashing down. Anyone in or on the bunker takes a wound on a roll of 4 or more. They may attempt an armour save to avoid damage. Survivors are placed up to 2" away from the ruined bunker.

BUNKER PENETRATING HITS

(S+D6 ROLL BEATS ARMOUR VALUE)

1-2 **Occupants Stunned.** Troops in and on the bunker may not move or fire next turn.

3-4 **Damage.** The bunker is damaged. Add +1 to all future rolls on the bunker damage tables. This +1 is cumulative, so another 'Damage' result would mean +2 on the next roll.

5-6 **Collapse.** The bunker comes crashing down. Anyone in or on the bunker takes a wound on a roll of 4 or more. They may attempt an armour save to avoid damage. Survivors are placed up to 2" away from the ruined bunker.



HIDDEN SET-UP

In some scenarios, forces have had time to conceal their troops and prepare booby traps and minefields to delay the enemy. When using Hidden Set-up you will need a hidden set-up marker for every unit in your force (including those in reserve or not starting on the tabletop for some other reason).

When forces are deployed on the table the defender places hidden set-up markers instead of models. A marker may be placed on any terrain, as long as it can be moved over by the model it is representing, and is in the defender's normal deployment zone.

Each marker needs to be numbered so that you can note down which number corresponds to which unit – if you don't have any numbered markers simply make your own by tearing off some pieces of scrap paper and numbering them. Alternatively, the defender can draw a map of the tabletop and mark the location of each of his units on it.

Hidden Vehicles

Vehicles must be hidden in appropriate terrain features. It is not possible to disguise a Leman Russ battle tank on an open plain, but it could be hidden at the edge of a wood, behind a building or behind a hill. Vehicles must be hidden behind or in a terrain feature which could conceivably hide the model. Because people's terrain varies so much it is impossible to give an exhaustive list, so apply common sense. Obviously, it's much easier to hide a buggy than a tank.

Revealing Hidden Troops

Once the defender has placed all his hidden set up markers the attacker then deploys his forces as described in the Scenario Set-up rules. Once the attacker's deployment is complete the defender reveals his hidden set up markers and places the appropriate models on the table. For a unit of troops or multiple vehicles one model is placed on the counter with the rest of the unit in 2" coherency as normal. A lone vehicle must be placed on the counter itself. Counters which are for units in reserve have a chance of being a minefield or a booby trap.

Minefields and Booby Traps

If a counter is for a unit that is not deployed on the board, because it is in reserve or for any other reason, then there is a chance the counter represents a booby trap or minefield instead. Roll a D6: on a 4+ it is a booby trap or minefield (defender's choice), otherwise it is just a dummy – remove it from the table.

Booby Traps: The player controlling the booby trap may choose to detonate it when an enemy model or unit is within 6" of the marker. As usual, the owner of the target unit chooses which model takes the damage and resolves a single Strength 8 hit, Armour Piercing 2, on him. Unlike minefields booby traps only work once, so remove the marker once the attack has been made.

Minefields: A minefield is an 8" by 4" rectangle, placed in contact with the hidden counter.

Any enemy model moving over a minefield triggers a mine on a roll of 4+, taking a Strength 6 hit with no Armour Piercing value. Vehicles take a Strength 6 hit against their rear armour, but all penetrations are glancing hits only.

Skimmers and Minefields: Minefields will contain specialised devices with proximity detectors, the ability to leap upwards, or simply detonate in such a spectacular fashion that being a few metres in the air is no defence. Because of this, skimmers and troops with jump packs are affected by minefields just like ordinary troops and vehicles.

INFILTRATORS

Infiltrators are skilled at sneaking forwards to scout out the enemy before the main force arrives. By making the best use of available cover, advancing at night or with other troops providing diversions, they are able to deploy ahead of the rest of the army.

The way that this is represented in the game varies from mission to mission, but will typically involve placing the Infiltrators last or allowing them an extra move in the turn they move onto the battlefield. Often only one side may use its infiltrating troops fully as their enemy is caught off guard; the missions will specify when this is the case. If Infiltrators are not specifically mentioned then they simply deploy with the rest of the troops, the circumstances of battle not allowing them time to use their special skills.

NIGHT FIGHTING

Spotting the enemy at night is difficult. Not only is it dark, but the shifting shadows make identification of enemy troops uncertain. Warriors on both sides become confused and disoriented and their performance becomes unpredictable, some failing to fire at nearby enemies whilst others continue to blaze away confidently at long range.

Before a unit fires you must check if they can see the enemy. Roll a 2D6 and multiply the result by 3, giving a number between 6 and 36. This is the number of inches the unit can see. If any enemy are visible then they may be fired at as normal. Note you should only roll for each unit once, not for each model or weapon in a unit. Guess range weapons may fire as normal, but the distance they scatter is doubled if the target is beyond visual range.

Strike fast and suddenly. Attack without warning. Secure victory before the foe is aware of his danger. Remember always, a war is easily won if your enemy does not know he is fighting.

*Maxims of Macharius II, Lord General Solar, as quoted in the
Macharian Heresy by Lord Inquisitor Kryptman*

OBSTACLES

Fortifications are not the only form of defences. In some scenarios the defender may place obstacles. Obstacles are a hindrance to enemy movement and are split into two categories: razorwire and tank traps.

Razorwire. If the defender has suitable models then he may set up razorwire. Razorwire comes in 6" long sections. If the defender has obstacles then he gets 1D3+3 sections of razorwire to deploy at the start of the game.

Razorwire counts as difficult ground for all infantry, cavalry and bikes. Vehicles can drive over razorwire with no effect. Skimmers and jetbikes are not affected by razorwire, neither are jump pack troops.



Tank Traps. Tank traps also come in 6" long sections. If the defender has obstacles then he gets 1D3+3 sections of tank traps to position at the start of the game.

All vehicles, except skimmers, treat tank traps as impassable ground. Tank traps do not affect infantry movement, they can simply run around or clamber over them. Tank traps will provide cover for infantry.

Tank traps may be destroyed by enemy fire. They have an Armour Value of 10, and any penetrating hit destroys the section automatically. Glancing hits have no effect. They may be assaulted by infantry as if they were a stationary vehicle.

THE CONCLAVE OF HAR

Though I have seen within the Black Library and spoken to its most terrible guardian, I can never reveal what happened there; not to any man nor the Emperor himself for I am forsworn to powers beyond your knowledge. I can only say that a time of inconceivable horror is about to begin, a time when Mankind alone with the might of the Imperium cannot endure; and together with all the strength of the Eldar, even so, our doom stalks us unflinching across the stars.

Inquisitor Czevak at the Conclave of Har
from the Har transcriptorium

PRELIMINARY BOMBARDMENT

In a major offensive the attacker will often attempt to soften up his target with a heavy bombardment before launching his attack. The barrage could come from artillery units far in the rear, close support vehicles like Griffons and Whirlwinds, or from orbital barrages and air strikes. All races and armies have their own forms of artillery support and aircraft, be they Tyranid Biovores and Dactylis, Eldar Night Spinners, Chaos artillery, Ork Fighta-bommerz, or whatever.

A Preliminary Bombardment is unlikely to cause massive damage to a well dug in force, but it will make the enemy troopers keep their heads down and some of them will be so dazed that they only react slowly to the assault which follows. The huge ground-shaking explosions of the bombardment can also help clear the way for an attack by destroying fixed defences like razorwire and tank traps.

Roll a D6 for each enemy infantry, bike or cavalry unit and each section of razorwire or tank traps on the tabletop. On a roll of 6 the unit or obstacle is hit. A squad takes 1D6 hits from the shelling, causing 1 wound each (make armour saves as normal), and must roll a Leadership test or be pinned in their first turn – see the barrage section of the rules for details. Troops which start the game in reserve cannot be hit by a Preliminary Bombardment.

A section of razorwire or tank traps is automatically destroyed by being hit, remove it from play.

Vehicles and bunkers are not affected by a Preliminary Bombardment, (long range shelling lacks the accuracy to hit specific targets), but you should still roll for troops inside them. (Some of the troops may have been caught in the open whilst running for the cover of their vehicles, or they may refuse to dismount from their armoured carriers for fear of more shelling.)

RANDOM GAME LENGTH

Some scenarios have a Random Game Length to introduce an element of uncertainty into the hapless commander's plans. Random Game Length might represent the amount of time remaining until dawn or dusk, the imminent arrival of overwhelming enemy forces, shortages of fuel or ammunition or the effects of battles taking place on other sectors of the battle front.

A game of random length will always last a minimum of 4 turns.

At the end of the 4th turn, roll a dice: on a roll of 2+ there is a 5th turn for both players. At the end of the 5th turn roll a dice: on a 3+ there will be a 6th turn, and so on. The roll needed to get another turn is shown on the table below.

If the roll is failed then the game ends.

	Turn 4	Turn 5	Turn 6	Turn 7	Turn 8+
Next turn on...	2+	3+	4+	5+	6+

RESERVES

Reserves are forces which are in the same area or sector as the troops on the battlefield and are available to reinforce the troops engaged with the enemy. These are also the troops held back to plug gaps in a defensive line or to exploit breakthroughs by a vanguard.

Troops in reserve are not deployed at the start of the battle, but will become available in later turns of the game. Roll for each unit separately at the start of the player's turn. No reserves can enter play on the first turn.

	Turn 1	Turn 2	Turn 3	Turn 4+
Reserves arrive on...	-	4+	3+	2+

Once the reserves arrive they must move on from the table edge in the player's deployment zone, unless specified otherwise in the scenario. Note that you must bring reserves onto the tabletop on the turn they arrive, they can't hang around off the edge of the battlefield and wait for others to turn up!

In the case of a unit being carried by a transport vehicle just roll to see if the transport turns up. If the transport arrives it will automatically bring the unit along with it.

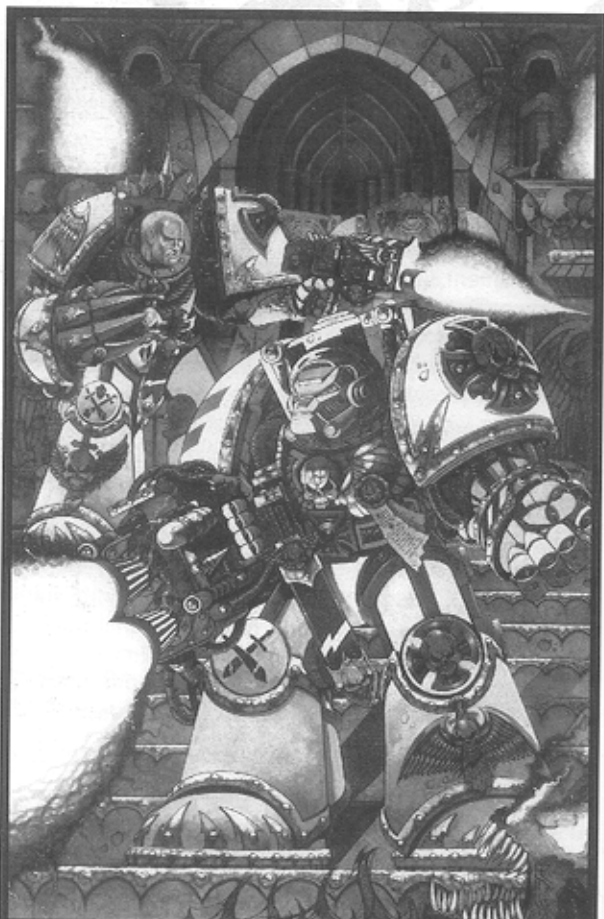

Tremble foes of Man, for the might of the Adeptus Astartes never rests in the Emperor's work.

SENTRIES

In certain scenarios the defender has set up sentries to keep a lookout for enemy activity. Sentries can be represented with card counters, but it is preferable to use spare miniatures of the appropriate type.

The number of sentries available depends on which army you are commanding and is given on the following list. These sentries do not cost any extra points.

Orks: 12 Gretchin (Initiative 2).

Imperial Guard: 10 Guardsmen (Initiative 3).

Sisters Of Battle: 8 Battle Sisters (Initiative 3).

Tyranids: 8 Termagants (Initiative 4).

Eldar: 8 Guardians (Initiative 4).

Space Marines: 6 Space Marines (Initiative 4).

Chaos: 6 Chaos Space Marines (Initiative 4).

Dark Eldar: 6 Dark Eldar Warriors (Initiative 5).

At the start of the sentries' turn, both players roll a dice for each sentry model (or marker). The player that rolls highest can move the sentry the distance indicated on the dice in any direction. If the rolls are tied then the defender moves the sentry.

Sentries do not have any squad coherency rules and operate independently.

Sounding The Alarm

At the start of the game, the defending forces are not expecting combat. Instead they are resting, eating, servicing equipment, talking about the girls/bug-eyed monsters back home and so on. Because of this, only the sentries will be active to start with.

Until the alarm is raised, sentries move as described above and none of the defender's other units may move or fire. The alarm can be raised in several ways.

Spotting Distance. A sentry will spot any enemy model that is within his spotting distance at the end of any turn. This distance is equal to his Initiative characteristic in inches. For example, a sentry with an Initiative value of 4 would spot any attackers within 4" of him, regardless of whether the attacker is in cover or not.

Vehicles. If the attacker deploys any vehicles or bikes on the table then the sentries will spot them at the end of the turn. Tanks, Dreadnoughts, armoured personnel carriers, etc are all too noisy to avoid detection. This does not apply to vehicles kept in reserve, unless they enter the board in the attacker's subsequent turns.

Weapons Fire. The alarm is raised if the attacker fires any weapons except sniper rifles. If a sentry survives being hit by a sniper rifle he raises the alarm.

Close Combat. A sentry that is attacked in close combat will raise the alarm if he survives to the end of the turn. If the sentry is killed in close combat then the noise of the fighting may raise the alarm anyway. Roll a D6, on a 4+ the fighting was heard or the sentry screamed out and the alarm is raised. A unit which kills a sentry in close combat cannot make a sweeping advance – because they're sneaking up they can only consolidate.

Bodies. If a sentry is killed do not remove the model. Instead, leave it lying in position. If another sentry approaches within his Initiative distance of a dead sentry then he will find the body and raise the alarm.

Note that all the other defending models count as sentries for purposes of sounding the alarm, they just can't move.

After raising the alarm all sentries are removed; they go to ground, run away or move to rejoin their units and take no further part in the game. The defender then takes a turn immediately, moving and fighting as normal with his remaining forces.

SUSTAINED ATTACK

Occasionally the enemy will have an overwhelming superiority in numbers, with wave upon wave of foes hurling themselves forward. To represent the size of an attack like this, the player making the Sustained Attack can 'recycle' some of his units when they are destroyed. Recycled units are brought back into play to represent the almost limitless supply of reinforcements.

Any Troops unit (ie Troops choices on the force organisation table) which is wiped out may move on from the attacking player's own board edge or either of the short table edges outside of the enemy deployment zone. They move on at the beginning of the attacker's next turn.

Units which are forced to fall back and reduced to less than 50% strength (ie are unable to regroup) can be removed from the table immediately and re-used as if they had been wiped out. They do not have to fall back completely off the table.

Destroyed vehicles and HQ units cannot be recycled. Note that this includes transport vehicles for Troops units and Command Sections for Imperial Guard infantry platoons.

VICTORY POINTS

Victory points are added up at the end of the game as a way of determining who has won the battle. To work out your victory points total you must add together the points value of the enemy units you have destroyed or seriously damaged.

Each unit wiped out is worth its points cost as victory points to the enemy. A unit which falls back off the edge of the table or is falling back at the end of the game counts as being wiped out.

If a unit has lost half or more of its models then it is worth half its total points value as victory points. If it has lost less than half of its models then it is worth no victory points to the enemy.

Vehicles which have been damaged (immobilised or armament destroyed) are worth half their points value, those which have been destroyed are worth their full points value. Even if you are using a unit of several vehicles (like Eldar Vypers, for example) count victory

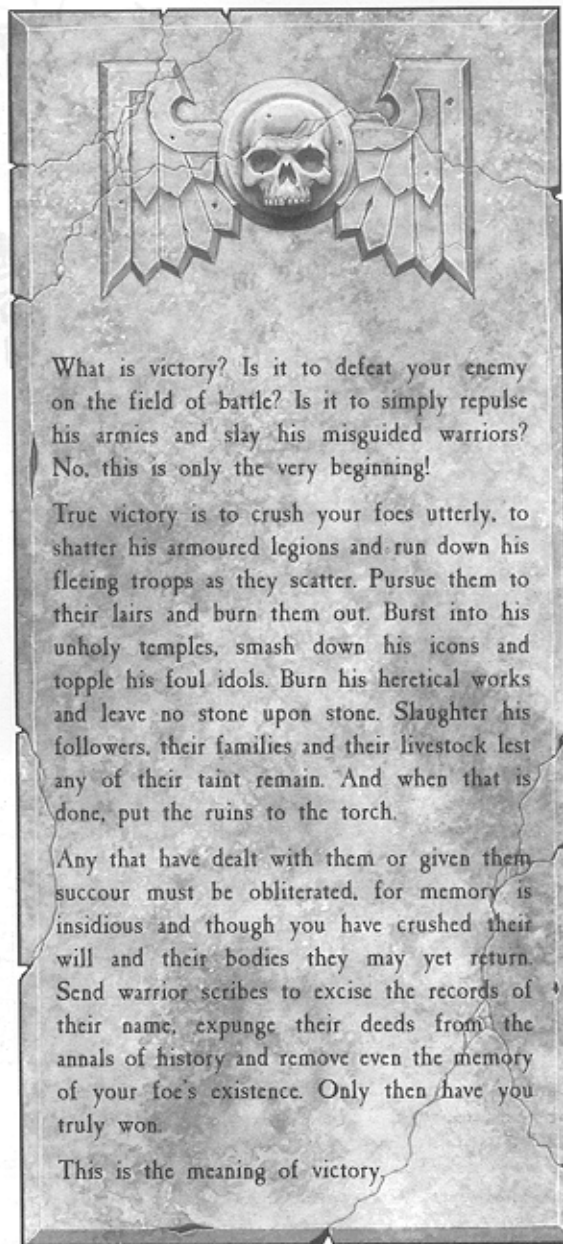

points for each vehicle separately. For example, if a unit of two Eldar Vypers suffered one damaged and one destroyed the enemy would get full victory points for one and half victory points for the other.

Individual models with two or more Wounds are worth half their points value if reduced to half Wounds, and their full value if killed.

As well as the points for destroying the enemy, many missions award additional victory points for successfully completing objectives during the game. These extra victory points are noted in the relevant mission's description and should be included in each player's total at the end of the game.

Add together the points values of everything destroyed, damaged or below half strength for each side. Add to that any points for achieving mission objectives. The side with the most victory points wins the game.

STANDARD MISSIONS

STANDARD MISSION SCENARIOS

In the Standard Mission scenarios your commander has been given certain tasks to complete in a specified area. Resources are limited and the missions may require a wide variety of different tactics to succeed so choose your forces carefully to ensure that any mission can be undertaken. The following units are available.

STANDARD MISSIONS

COMPULSORY

1 HQ
2 Troops

OPTIONAL

1 more HQ
4 more Troops
3 Elites
3 Fast Attack
3 Heavy Support

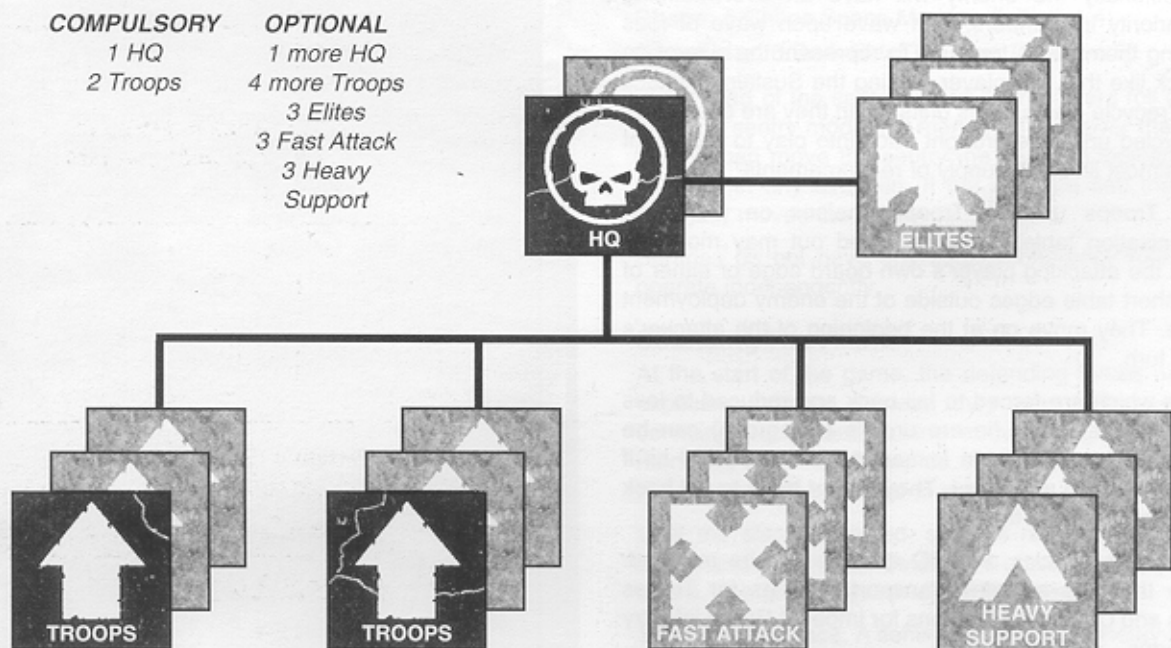

FORCES

Both sides pick forces from the standard missions organisation, to an agreed points value.

TERRAIN

For Standard missions, set up the terrain using any mutually agreeable method.

YOUR FIRST BATTLES

If you haven't played any of the standard missions before we'd recommend starting with *Cleanse* for your first battle and then working your way through the other missions by playing *Night Fight* and then *Patrol* and so on. This is because the Standard missions get gradually more complex and introduce more special rules as you go along.

SELECTING A MISSION

There are 5 Standard missions. Roll a D6 to randomly determine which mission you will be required to undertake.

- | | |
|---|---------------------|
| 1 | CLEANSE MISSION |
| 2 | NIGHT FIGHT MISSION |
| 3 | PATROL MISSION |
| 4 | RECON MISSION |
| 5 | RESCUE MISSION |

6 **Change of Orders.** Last minute orders come through sending your forces into battle! Roll to see which of the Battle scenarios you undertake, and randomly determine (or use strategy ratings) who is the attacker and who is the defender. However, do not reselect your armies – forces remain those chosen from the Standard missions' force organisation chart.

1 CLEANSE MISSION

OVERVIEW

Both sides are attempting to sweep the area clean of opposing troops. Roving forces must be on the lookout to seek and destroy any enemies they encounter.

SCENARIO SPECIAL RULES

None.



SET-UP

1 Divide the board into four quarters. Both players roll a dice, the player with the highest score may pick which quarter to deploy in. The other player's deployment zone is the opposite quarter.

D The player that scored lowest now deploys one unit in his quarter of the board. His opponent then deploys a unit in his deployment zone. The players take it in turns deploying a unit at a time until both their entire forces are on the table.

No unit may be deployed with 18" of the enemy. The players must deploy their units in the following order: Heavy Support first, followed by Troops, Elites, HQ and finally Fast Attack units.

D Roll for who gets first turn. Highest score may choose whether to go first or second.

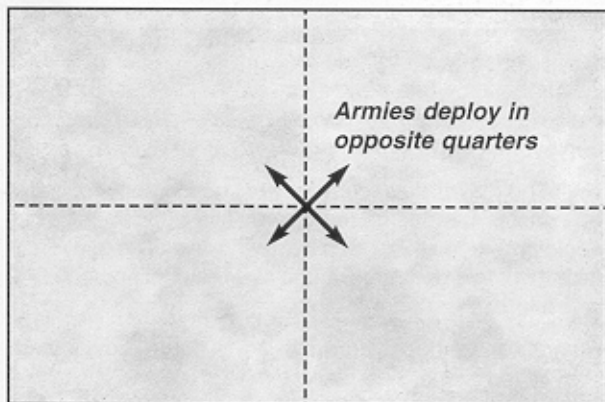

Divide the table into 4 quarters and dice for choice of quarter as deployment zone.

MISSION OBJECTIVE

Both forces are seeking to clear the area of all enemy forces, securing ground as they go. The player that occupies the most quarters of the board at the end of the game wins.

To claim a table quarter as occupied there must be no enemy units of troops, bikes or cavalry over half strength or mobile vehicles in the area. You must have a mobile vehicle, or at least one unit of troops, bikes or cavalry with more than half their original number of models in the area. Note that characters do not count as units and so may not secure table quarters on their own.

RESERVES

None.

GAME LENGTH

The game lasts for six turns.

LINE OF RETREAT

Troops which are forced to fall back will do so towards the nearest board edge of their deployment zone, using the normal Fall Back rules.



NIGHT FIGHT MISSION

OVERVIEW

Both sides have unexpectedly collided with an enemy force whilst moving forward at night. Muzzle flashes and tracer rounds criss-cross the battle as both sides attempt to locate and destroy the enemy. This is a variation on the Cleanse mission with a special rule to represent the darkness.

SCENARIO SPECIAL RULES

Night Fight missions use the *Night Fighting* and *Infiltrators* scenario special rules.

SET-UP

1 Divide the board into four quarters. Both players roll a dice, the player with the highest score may pick which quarter to deploy in. The other player's deployment zone is the opposite quarter.

D The player that scored lowest now deploys 1 unit in his quarter of the board. His opponent then deploys a unit in his deployment zone. The players take it in turns deploying a unit at a time until both their entire forces are on the table.

No unit can be deployed within 24" of the enemy at the start of the game. The players must deploy their units in the following order: Heavy Support first, followed by Troops, Elites, HQ and finally Fast Attack units.

If either side has any Infiltrators, they may make one move after deployment but before the game starts.

3 Roll for who gets first turn. Highest score may choose whether to go first or second.

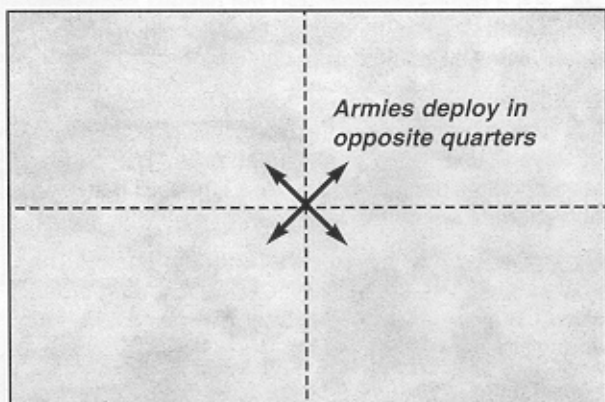

Divide the table into 4 quarters and dice for choice of quarter as deployment zone.

MISSION OBJECTIVE

Both forces are seeking to clear the area of all enemy forces, securing ground as they go. The player that occupies the most quarters of the board at the end of the game wins.

To claim a table quarter as occupied there must be no enemy units of troops, bikes or cavalry over half strength or mobile vehicles in the area. You must have a mobile vehicle, or at least one unit of troops, bikes or cavalry with more than half their original number of models in the area. Note that characters do not count as units and so may not secure table quarters on their own.

RESERVES

None.

GAME LENGTH

The game last for six turns.

LINE OF RETREAT

Troops which are forced to fall back will do so towards the nearest board edge of their deployment zone, using the normal Fall Back rules.



§ PATROL MISSION

OVERVIEW

You have been detailed to patrol no man's land and drive off any enemy forces encountered. Additional forces are near at hand to secure victory, but be warned – the enemy have their own reserves and will attempt to do the same to you.

SCENARIO SPECIAL RULES

Patrol missions use the *Random Game Length*, *Reserves* and *Victory Points* scenario special rules.

SET-UP

1 Both players roll a dice, the winner gets to choose his deployment zone. This can be either a long board edge or a corner. Units may be deployed up to 12" onto the board. If it is a corner then units may be deployed up to halfway along each board edge.

The opponent gets the opposite board edge or corner.

D Both players roll a dice, the loser deploys one unit of troops, this is his patrol. The winner then deploys one unit of troops in his deployment zone. The rest of their forces are in reserve.

§ Both players roll a dice, the player that rolls highest may choose whether to go first or second.

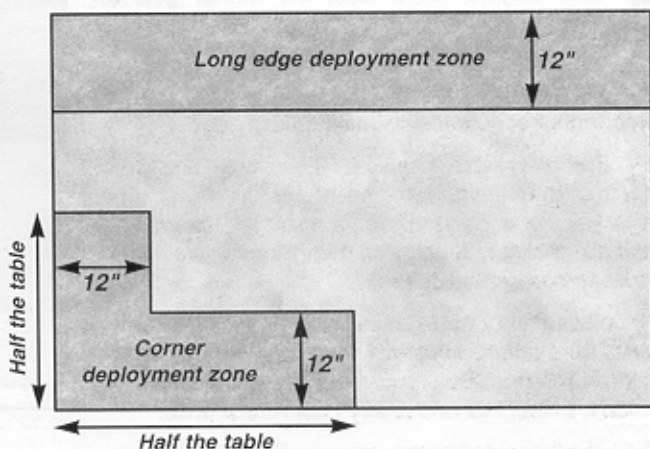

MISSION OBJECTIVE

Both players must attempt to eliminate the enemy without losing too much of their own strength. The player with the highest victory points total wins the game.



RESERVES

When either player's reserves become available they move on from that player's deployment zone board edge.

GAME LENGTH

The game lasts for a variable number of turns.

LINE OF RETREAT

Troops which are forced to fall back will do so towards the nearest board edge of their deployment zone, using the normal Fall Back rules.



4 RECON MISSION

OVERVIEW

Both sides are attempting to punch through the enemy lines to establish forward positions and probe the enemy's strength in preparation for a major attack.

SCENARIO SPECIAL RULES

Recon missions use the *Infiltrators* and *Victory Points* scenario special rules.

SET-UP

1 Both players roll a dice, the winner gets to choose which of the long board edges will be his deployment zone. Units may be deployed up to 18" onto the board.

The opponent gets the opposite board edge.

2 Both players roll a dice. The player that loses the roll off deploys one of his units first. The other player then deploys one of his units. The players alternate deploying in this way until their entire armies are on the table.

3 No unit may be deployed with 24" of the enemy. The players must deploy their units in the following order: Heavy Support first, followed by Troops, Elites, HQ and finally Fast Attack units.

4 If either side has any troops which can Infiltrate then they may deploy these units after all the other units have been placed. They may be placed anywhere on the battlefield which is 18" or more from an enemy unit. If both sides have Infiltrators roll a dice: the winner may choose whether to deploy his Infiltrators before or after enemy Infiltrators.

5 Both players roll a dice, the player that rolls highest may choose whether to go first or second.

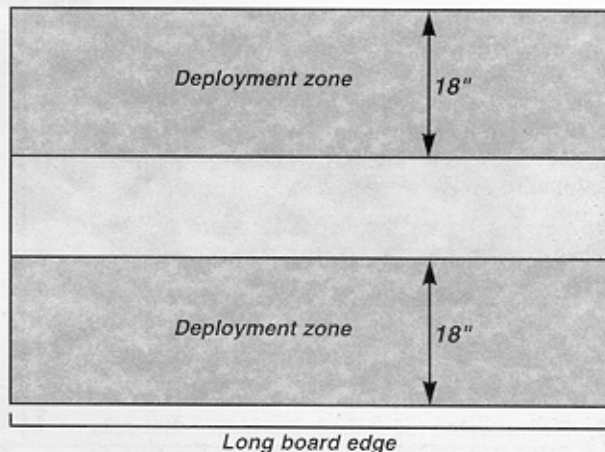

MISSION OBJECTIVE

Both players must attempt to get units into the enemy deployment zone. Each player gets bonus victory points for each unit he has in the enemy deployment zone at the end of the game.

Each undamaged vehicle, or unit of infantry, bikes or cavalry with over half its original number of models in the enemy deployment zone at the end of the game is worth +200 victory points. Each damaged vehicle or unit with less than half its original models in the enemy deployment zone is worth +100 points.

The player with the highest victory points total wins.

RESERVES

None.

GAME LENGTH

The game lasts for six turns.

LINE OF RETREAT

Troops which are forced to fall back will do so towards the long board edge of their deployment zone, using the normal Fall Back rules.



RESCUE MISSION

OVERVIEW

You have been sent to recover something valuable from the front lines. It might be plans or maps which were left on-board a wrecked vehicle, an item of spiritual significance or an individual such as a spy with vital information, an assassin or an injured commander lost in enemy territory. Both forces are sweeping the area for the prize and the battle begins when they clash somewhere near its location.

SCENARIO SPECIAL RULES

Rescue missions use the *Reserves* scenario special rule.

SET-UP

1 Before choosing table edges or deploying any forces the players place 6 counters, numbered 1 to 6, face down anywhere on the table, (without looking at the numbers on the counters!). The players should take turns placing 3 counters each. Each counter must be no closer than 12" to another counter and no closer than 12" to any board edge.

2 Determine which one of these counters is the objective by rolling a dice. The counter with that number on it is the real objective and must be discovered by the armies during the battle.

3 Both players roll a dice, the player that rolls highest chooses where he will deploy. He can choose to either deploy from a corner or a long board edge; he may not choose a short board edge. He may deploy up to 6" onto the board. His opponent gets the opposite deployment zone, so either both forces start in the corners or along either long board edge.

4 Both players roll a dice, the lowest dice roll deploys first. He may set up any or all of the units from his Troops allowance in his deployment zone. He does not have to deploy all his Troops, but he must deploy at least one unit. Any Troops not deployed are in reserve, as is the rest of his force. The winner then deploys his force.

5 Both players roll a dice, the highest score may choose whether to take the first or second turn.

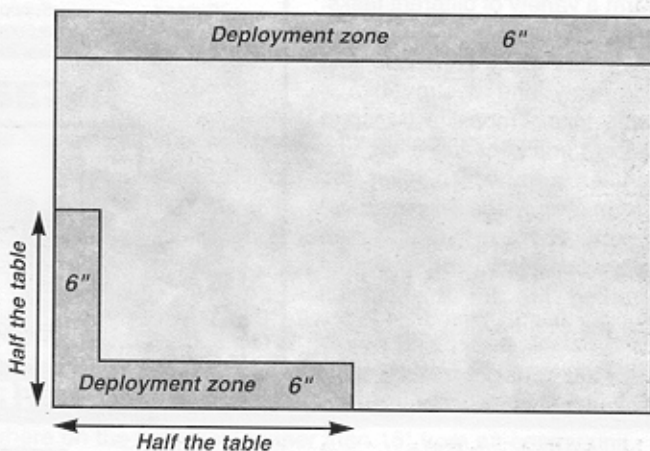

MISSION OBJECTIVE

The player in possession of the objective at the end of the game wins. If no one has the objective at the end of the game then it is a draw.

To reveal a counter the player must move a model into contact with it and halt the model's movement. Turn the counter face up and see which number it has on it. If the counter is the one with the number rolled at the start of the game the model has located the objective, and it is now in that model's possession. If the counter is any other number discard it and keep hunting.

If the model carrying the prize is killed or has to Fall Back then the counter is dropped and remains on the board. It may be picked up by any model that moves into contact with it.

The model can pass the objective to another model by moving into base contact. Neither model may move after they have come into contact until their next turn, and the objective can only be handed off once per turn.

RESERVES

None.

GAME LENGTH

The game lasts for six turns.

LINE OF RETREAT

Troops which are forced to fall back will do so towards the nearest board edge of their deployment zone, using the normal Fall Back rules.

BATTLES

BATTLE SCENARIOS

The Battle scenarios pit one player against another in a ferocious face-to-face struggle. Battles may be fought to capture a vital objective or annihilate the enemy's forces in a sustained attack. As a commander you will need a combination of tactical cunning and bloody-minded determination to overcome the foe.

ATTACKER'S ORGANISATION

As the attacker, you will need a versatile, efficient force which can perform a variety of different tasks. Most importantly, you will need some forces which can close with your enemy and destroy him – assault units, Troops in transport vehicles, jump packers, bikes and so on. An army which relies too much on long range firepower will not be able to move in and capture an objective. However, sufficient supporting fire for the assault forces will also be vital.

BATTLES

ATTACKER

COMPULSORY

1 HQ
1 Troops
1 Heavy
Support

OPTIONAL

1 more HQ
5 more Troops
2 more Heavy
Support
3 Elites
3 Fast Attack

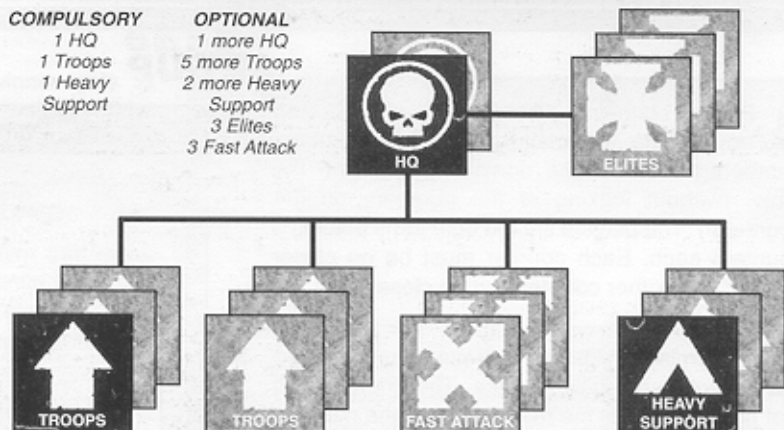

BATTLES

DEFENDER

COMPULSORY

1 HQ
2 Troops

OPTIONAL

4 more Troops
2 Elites
1 Fast Attack
3 Heavy
Support

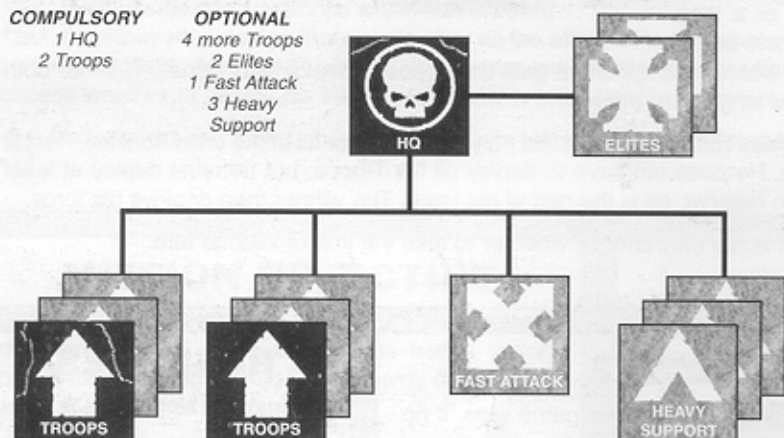

DEFENDER'S ORGANISATION

In a Battle, the defending forces need to be able to withstand a large amount of punishment and still put up a reasonable fight. You will find large units of Troops useful, with plenty of Heavy Support to break up the attack as it comes in. Some units capable of mounting a credible counter-attack will be important in case the attackers overrun your position or you need to recapture an objective taken by the enemy.

FORCES

Both players pick their forces from the Battle scenario's force organisation chart to an agreed points value.

TERRAIN

Set up the terrain using any mutually agreeably method.

SELECTING A MISSION

There are 3 Battle missions. Roll a D6 to randomly determine which mission you will be required to undertake.

- | | |
|-----|------------------------|
| 1-2 | TAKE AND HOLD MISSION |
| 3-4 | MEAT GRINDER MISSION |
| 5-6 | BUNKER ASSAULT MISSION |

1 TAKE AND HOLD MISSION

ATTACKER'S OVERVIEW

Your force has been given a specific location to capture from the enemy. This could be a hill, an important building, a bridge, a supply dump or some other feature. You must eliminate enemy forces in the area and hold your objective against enemy counter-attacks.

DEFENDER'S OVERVIEW

Your force currently holds a location of vital strategic importance. You must stop it falling into enemy hands at all costs. If overwhelming enemy forces do capture the location mount a counter-attack as soon as possible to regain it.

SCENARIO SPECIAL RULES

Take and Hold missions use the *Deep Strike*, *Infiltrators*, *Random Game Length* and *Reserves* scenario special rules.

SET-UP

- 1 Both players roll a dice, the player that rolls the highest can choose one of the long table edges as his table edge.
- 2 Both players roll a dice. The player that rolls highest chooses a piece of terrain to be the objective. This piece of terrain must be at least 24" from his own board edge, and may not be within 12" of any other board edge. It can be a building, a hill, a bridge, a pile of crates or anything else you might have in your terrain collection. This is the attacker's objective.
- 3 The defender deploys any of his Troops and Heavy Support within 12" of the objective. The defender does not have to deploy all these units, but he must deploy at least one. The rest of his forces are in reserve.
- 4 If the attacker has any troops which can Infiltrate then they may deploy these units after all the enemy units have been placed. They may be placed anywhere on the battlefield further than 18" from an enemy unit.
- 5 The attacker takes first turn, moving all his forces onto the tabletop from his table edge.

MISSION OBJECTIVE

The player that controls the objective at the end of the game wins the battle.

To control the objective you must have the closest unit to the objective at the end of the game. Immobilised vehicles or units of bikes, cavalry or infantry with more than 50% casualties cannot control the objective.



RESERVES

The defender's reserves move on from his table edge.

GAME LENGTH

The game lasts for a variable number of turns.

LINE OF RETREAT

Troops which are forced to fall back will do so towards their board edge by the shortest route possible, using the normal Fall Back rules.



D MEAT GRINDER MISSION

ATTACKER'S OVERVIEW

Your forces have been committed to the front line in an all out attack against the enemy. Your orders are simple: annihilate enemy forces, crush them entirely.

DEFENDER'S OVERVIEW

The enemy has launched an all-out attack which you must survive, destroying as many of his forces as possible. You are badly outnumbered, but must sell yourselves dearly to blunt the attack.

SCENARIO SPECIAL RULES

Meat Grinder missions use the *Deep Strike*, *Infiltrators*, *Random Game Length*, and *Sustained Attack* scenario special rules.

SET-UP

1 Both players roll a dice, the player that rolls highest chooses his deployment zone, which can be either of the long table edges. He may deploy his forces up to 12" onto the board.

The opposing player gets the opposite table edge. He may deploy his forces up to 12" onto the board.

D Both players roll a dice. The player that loses the roll off must deploy one of his units first. The other player then deploys one of his units. The players alternate deploying units in this way until their entire armies are on the table. The players must deploy their Heavy Support first, followed by Troops, Elites, HQ and finally Fast Attack units.

If either side has Infiltrators in his force then they may be deployed after all other units have set up. However, they are not restricted by the deployment zones, and may set up anywhere on the battlefield which is more than 18" from an enemy unit. If both sides have Infiltrators each player must roll a D6. The player with the highest score has the choice of deploying his Infiltrators first or second.

D Both players roll a dice, the highest score chooses whether to go first or second.

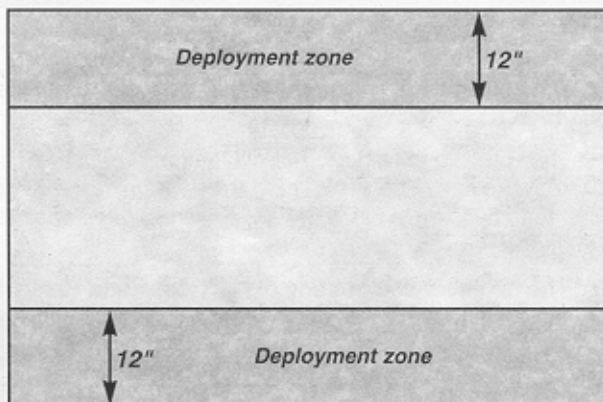

MISSION OBJECTIVE

To win the battle the attacker must annihilate the defender's army. He wins the battle if at the end of the game the defender has no forces left. If the defender has any forces remaining then he wins the battle.



RESERVES

None.

GAME LENGTH

The game lasts for a variable number of turns.

LINE OF RETREAT

Troops which are forced to fall back will do so towards their board edge by the shortest route possible, using the normal Fall Back rules.



§ BUNKER ASSAULT MISSION

ATTACKER'S OVERVIEW

The enemy have established a heavily fortified defensive line of bunkers, trenches and pillboxes. You have been ordered to assault the strongpoints and capture or destroy them.

DEFENDER'S OVERVIEW

Your forces are holding a well-defended part of the line with orders to hold off all attacks and, most importantly, prevent the bunkers from falling into enemy hands.

SCENARIO SPECIAL RULES

Bunker Assault missions use the *Deep Strike*, *Fortifications*, *Infiltrators*, *Preliminary Bombardment*, *Reserves* and *Victory Points* scenario special rules.

SET-UP

1 Both players roll a dice, the player that scores highest chooses which long edge he will deploy on.

2 The defender's deployment zone is up to 18" onto the board. He may set up fortifications anywhere in this zone and must include at least one bunker. The bunkers must be placed no closer than 6" to any table edge.

3 The defender deploys any of his Troops and HQ units in his deployment zone. He does not have to deploy all these units, but must deploy at least one. Any units not deployed are in reserve.

4 Once the defender has deployed, the attacker deploys his entire army up to 12" onto the tabletop from his board edge.

If the attacker has any Infiltrators in his force then they may be deployed after the defender has set up, as described above. However, they are not restricted by the deployment zones, and may set up anywhere on the battlefield which is more than 18" from an enemy unit.

5 The attacker resolves his Preliminary Bombardment.

6 Roll for who gets first turn. The player that rolls highest chooses whether to go first or second.

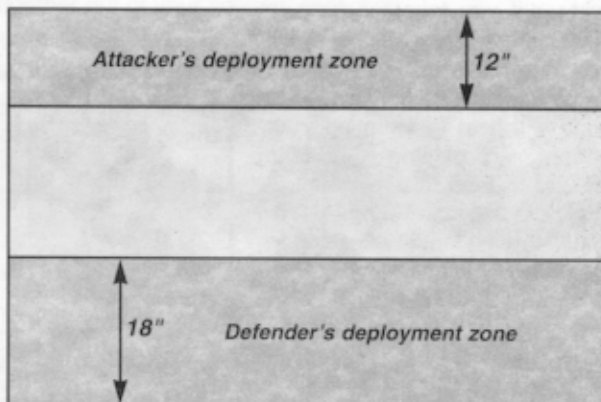

MISSION OBJECTIVES

The attacker must destroy or occupy the bunkers. For each bunker destroyed, or occupied only by his troops at the end of the game, he gains +150 victory points.

The defender must hold the attacker off and retain control of as many bunkers as possible. For each bunker occupied only by the defender's troops at the end of the game he gains +150 victory points.

At the end of the game add up victory points for enemy units destroyed and bunkers destroyed or captured. The highest score wins.

RESERVES

The defender's reserves move on from his table edge.

GAME LENGTH

The game lasts for six turns.

LINE OF RETREAT

Troops which are forced to fall back will do so towards their board edge by the shortest route, using the normal Fall Back rules.

RAIDS

RAID SCENARIOS

In a Raid scenario one player will be the attacker whilst the other player is the defender. Raids are lightning strikes against a specific objective such as an ambush of an enemy column, a surprise attack on an important enemy strongpoint, or secret missions deep behind enemy lines.

ATTACKER'S ORGANISATION

A raiding force should be fast moving and hard-hitting with plenty of Elite and Fast Attack units. You will need to complete your mission quickly – if you take too long to achieve your objective, you risk being overwhelmed by enemy reinforcements. A solid core of Troops will help to keep up your numbers, providing reliable firepower to fend off any counter-attack or to deliver a killing blow to enemy forces. Infiltrators often come in particularly useful in Raid scenarios.

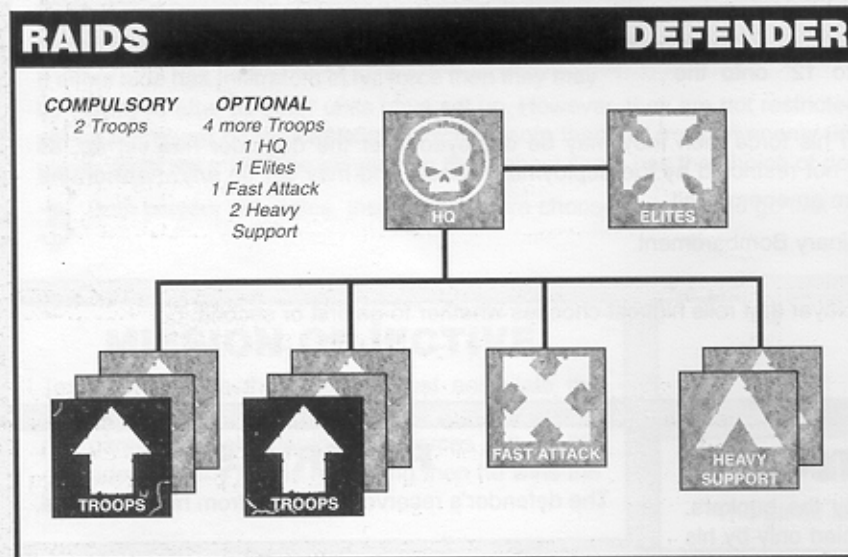
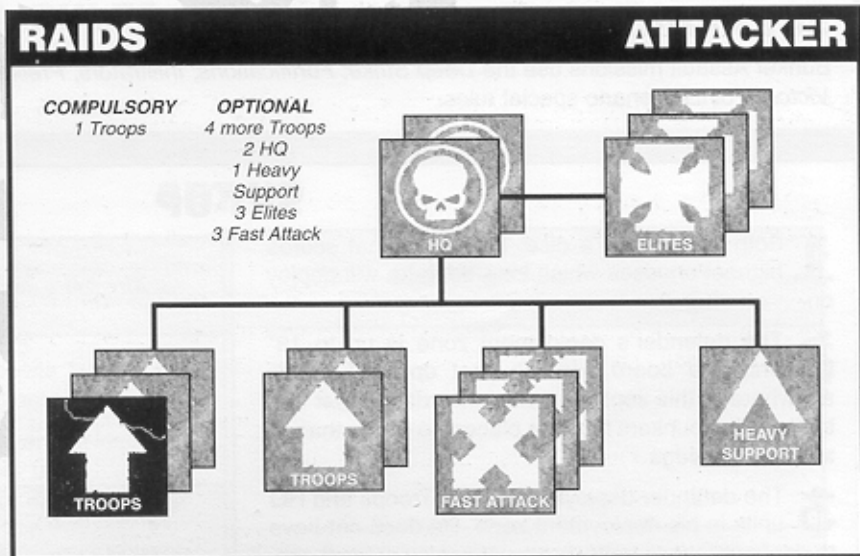

DEFENDER'S ORGANISATION

Defending against a Raid requires nerves of steel and a balanced mix of units. Heavy Support units will be important to keep the foe at bay or provide heavy reinforcements. Troops will be needed to guard objectives and tie down raiders in costly firefights and close combats where their greater numbers will prove more useful than any amount of big guns. Having an Elite unit will allow you to mount a counter-attack to drive the enemy away from their objective and put them on the defensive.

FORCES

Both sides pick forces from the Raid force organisation to an agreed points value.

TERRAIN

Set up the terrain in any mutually agreeable manner. Ideas for setting up terrain are given earlier in the Battles Book.

SELECTING A MISSION

There are 3 Raid missions. Roll a D6 to randomly determine which mission to play.

- 1-2 SABOTAGE MISSION
- 3-4 AMBUSH MISSION
- 5-6 STRONGPOINT ATTACK MISSION

1 SABOTAGE MISSION

ATTACKER'S OVERVIEW

You are leading a force on a surprise raid deep in enemy territory. Your mission is to sneak through enemy lines and destroy an important installation. This could be a fuel or ammo dump, a command bunker, a bridge or a communications station.

DEFENDER'S OVERVIEW

You command the forces defending an important installation against any enemy attack. Reserves are available in case of attack.

SCENARIO SPECIAL RULES

Sabotage missions use the *Infiltrators*, *Random Game Length*, *Reserves* and *Sentries* scenario special rules.

SET-UP

1 Place the objective of the raid in the centre of the table. This can be a command post, a fuel dump, an ammo dump, a radio mast or anything else you can put together out of your scenery collection.

P The defender may set up any of his Troops and HQ units anywhere within 8" of the objective. He does not have to set them all up, but he must deploy at least one unit. Any forces not deployed are in reserve.

\$ The defender gets a variable number of sentries to place depending on which army he is commanding (see the scenario special rules). These sentries do not cost any extra points.

The sentries are placed anywhere on the table which is not within 12" of a short table edge, and not in the defender's deployment zone.

4 The attacker chooses one of the short table edges as his board edge. If the attacker has any troops that can infiltrate then he may deploy them up to 12" onto the board from his table edge in the area shown on the map.

\$ The attacker takes the first turn, moving as much of his army as he chooses onto the board, and leaving the rest to come on as reserves.

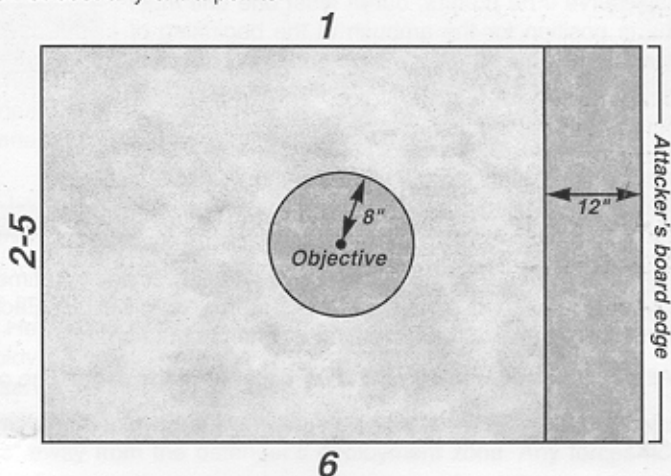

MISSION OBJECTIVE

For this raid all the attacking forces have been issued with demo charges to destroy the objective and complete their mission. The objective cannot be destroyed by firing at it, only by placing demo charges. To place a demo charge successfully, the model must assault the objective in its assault phase and remain in contact until its next assault phase. At this point the charge is set and the objective is destroyed. Boom!

The attacker wins if he destroys his objective, otherwise the defender wins.

RESERVES

The attacker's reserves enter from his board edge. The defender's reserves enter from a random board edge, as indicated on the map (roll a D6). Only begin rolling for the defender's Reserves after the alarm has been raised. The first turn they can appear they arrive on a 4+, the next turn a 3+, and so on, as usual.

GAME LENGTH

The game lasts for a variable number of turns.

LINE OF RETREAT

Troops which are forced to fall back will do so towards their closest board edge by the shortest route possible, using the normal Fall Back rules.



AMBUSH MISSION

ATTACKER'S OVERVIEW

Your forces are lying in wait for a convoy of enemy reserves heading for the front line. You must destroy the convoy whilst minimising your own losses.

DEFENDER'S OVERVIEW

Your force is moving towards the front line to reinforce the troops fighting there. You must escape the ambush with as much of your force intact as possible.

SCENARIO SPECIAL RULES

Ambush missions use the *Hidden Set-up*, *Random Game Length*, *Reserves* and *Victory Points* scenario special rules.

SET-UP

1 The defender chooses one of the short table edges as his escape route.

D The attacker rolls a dice for each of his units: on a 3+ they may be deployed at the start of the game. The attacker may choose to leave units in reserve if he prefers, but at least one unit must be in position for the ambush at the beginning of the game. If the attacker fails to get any of his units at the start of the game he must choose one unit to make the ambush. Any forces which are not ambushing are in reserve. The attacker sets up the ambushing forces using the *Hidden Set-up* rules. *Hidden Set-up* counters may be placed no closer than 18" to the defender's set-up zone.

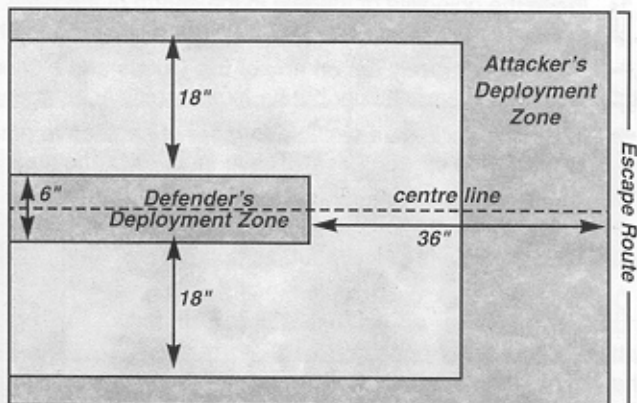

3 The defender places his squads and vehicles one at a time. The front unit of the column must be at least 36" from the short table edge which is the escape route. Each subsequent unit or vehicle must deploy entirely behind the previous unit, creating a column of march.

All of the defender's army must be within 3" of the centre line of the board, facing towards the escape route.

4 The attacker has first turn.

MISSION OBJECTIVE

The attacker must destroy as much of the enemy convoy as possible, whilst the defender must attempt to escape the trap.

Add the points value of each unit the defender manages to get off the escape route board edge to his victory points total. So if a squad worth 100 points escapes then add 100 points to the defender's victory points total.

The player with the highest victory points total wins the battle.

RESERVES

The attacker's reserves may enter the board from either of the long board edges.

GAME LENGTH

The game lasts for a variable number of turns.

LINE OF RETREAT

Attacking troops which are forced to fall back will do so towards the closest of the long board edge, by the shortest possible route, using the normal fall back rules. Defending troops which are forced to Fall Back will do so directly away from the escape route edge by the shortest possible route using the normal Fall Back rules.

§ STRONGPOINT ATTACK MISSION

ATTACKER'S OVERVIEW

You are to launch a surprise attack against an enemy strongpoint and eliminate it before enemy reserves can react.

DEFENDER'S OVERVIEW

Your forces are holding a well defended strongpoint. Your task is to guard the strongpoint and hold off any enemy attack until reserves can move up to support you.

SCENARIO SPECIAL RULES

Strongpoint Attack missions use the *Deep Strike*, *Fortifications*, *Infiltrators*, *Obstacles*, *Reserves*, *Sentries*, *Victory Points* scenario special rules.

SET-UP

- 1 Each player rolls a dice. The winner chooses a long board edge.
- 2 Mark a 24" square area central to the defender's edge of the board, as shown on the map. This is the defender's deployment zone.
- 3 The defender may position fortifications in his deployment zone, forming the strongpoint. He must include at least one bunker in his defences.
- 4 The defender positions his sentries. These are placed within 18" of the outside of his deployment zone. The number of sentries varies depending on the defending army (see the scenario special rules).
- 5 The defender places his obstacles. They may be placed anywhere on the tabletop up to 18" away from the defender's deployment zone.
- 6 The defender deploys any of his HQ, Troops or Heavy Support units in his deployment zone. He does not have to deploy them all, but he must deploy at least one unit. Any units not deployed are in reserve.
- 7 If the attacker has any Infiltrators then they may be deployed anywhere outside the defender's deployment zone. Other units must be placed at least 18" away from the defender's deployment zone. Any forces not deployed at the start are in reserve.
- 8 The attacker gets the first turn.

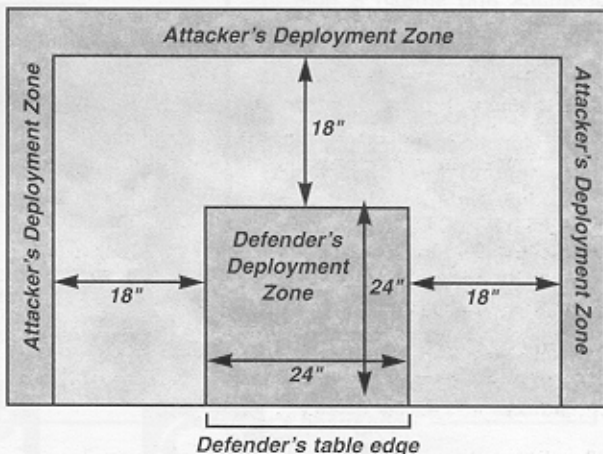

MISSION OBJECTIVES

The attacker must crush the defenders, and gains +200 victory points for each bunker he destroys.

The defender needs to hold out until his reserves arrive and gains +200 victory points for each bunker occupied only by his troops when the raid is over.

At the end of the game add up victory points. The highest score wins.

RESERVES

When the defender's reserves arrive they move on from the defender's board edge. The attacker's reserves move on from any of the other board edges.

GAME LENGTH

The game lasts for four turns after the alarm has been raised.

LINE OF RETREAT

Troops which are forced to fall back will do so towards their board edge by the shortest route possible, using the normal Fall Back rules.

BREAKTHROUGH

BREAKTHROUGH SCENARIOS

In these scenarios one player takes the role of the attacker whilst the other player is the defender. Breakthrough scenarios involve one force trying to punch a path through an opposing force. This might be because they are seeking to escape from an encirclement, or to smash through the enemy's defensive lines in a major attack. The following units are available.

ATTACKER'S ORGANISATION

In a Breakthrough the attackers will have to battle their way through strong opposition and cover a lot of ground to exploit their success. Elite units will give you a compact, powerful strike force to spearhead your attack and smash a hole in the enemy line. Plenty of mobile Heavy Support could also open up a breach. However you create the gap, lots of Troops in transport vehicles and Fast Attack units will be necessary to flood through and secure your victory.

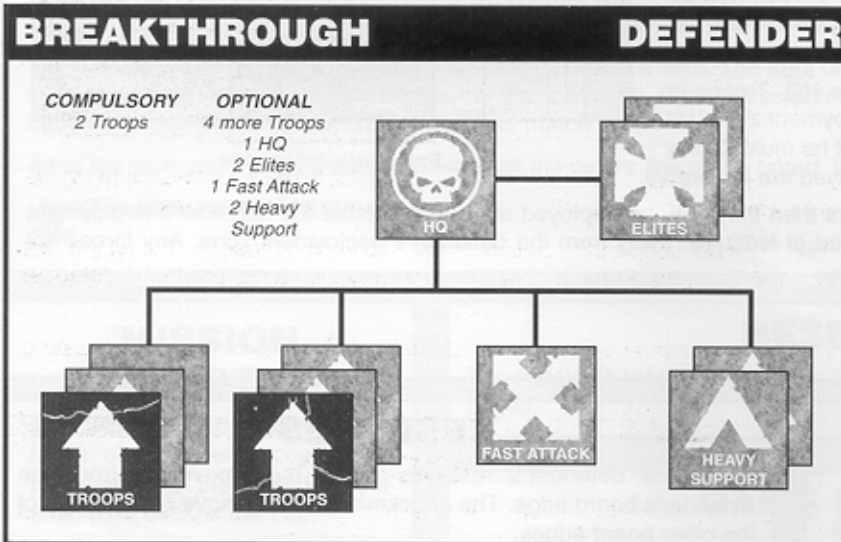
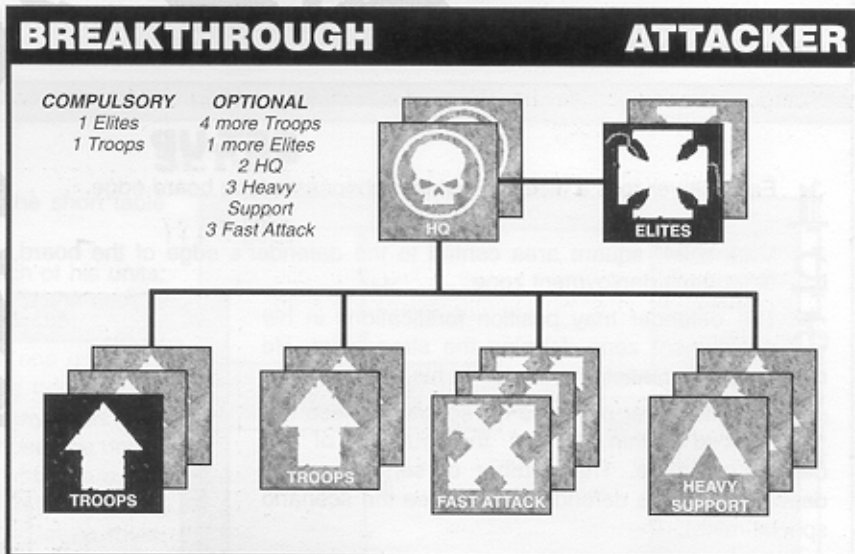

DEFENDER'S ORGANISATION

When defending against a Breakthrough, you should mainly rely upon your units of Troops which can cover a wide area and are still tough enough to withstand a determined attack. Heavy Support will be useful for blunting the attacker's assault before it reaches your line. These units need to be backed up by sturdy Fast Attack or mobile Elite forces which can plug any breaches made by the attacker.

FORCES

Both players pick their forces from the Breakthrough scenarios organisation to an agreed points value.

TERRAIN

Set up the terrain in any mutually agreeably manner.

SELECTING A MISSION

There are 3 Breakthrough missions. Roll a D6 to randomly determine which mission you will be required to play.

- | | |
|-----|-------------------|
| 1-2 | REARGUARD MISSION |
| 3-4 | BREAKOUT MISSION |
| 5-6 | BLITZ MISSION |

1 REARGUARD MISSION

ATTACKER'S OVERVIEW

The offensive is pushing the enemy back all along the front, and your advance is in full flood. You have been ordered to spearhead the attack in this sector, sweeping aside any pockets of resistance as quickly as possible.

DEFENDER'S OVERVIEW

Your army has been driven back by the enemy offensive, and you need time to regroup. Your force has been selected as the rearguard of your retreating army. You must stall the enemy advance as long as possible with whatever forces are available and give the rest of your army a chance to form a new defensive line.

SCENARIO SPECIAL RULES

Rearguard missions use the *Deep Strike*, *Hidden Set-up*, *Infiltrators*, *Obstacles*, *Random Game Length* and *Reserves* scenario special rules.

SET-UP

1 Both players roll a dice. The player that rolls highest chooses which long board edge to deploy from.

2 The defender must split his army into two groups, each must contain at least one unit, but is not restricted in any other way. Before deploying, the defender flips a coin or rolls a dice to see which group he will use. The units in the other force are not used in this battle.

3 The defender's deployment zone is up to half way across the table. The defender deploys the part of his force that is available in his deployment zone using the Hidden Set-up rules. He also places obstacles in his deployment zone. If he chooses he may leave any Deep Strike units he has in reserve.

4 The attacker splits his army into two waves. Each wave must contain at least a third of the total points value of the army. Note down which units are in which wave, squads cannot be split between waves.

5 The attacker takes the first turn. He may hold Deep Strike units from the first wave in reserve, but all the rest of the wave moves on from his board edge in his first turn. Once the first wave is on the board the defender reveals his Hidden Set-up markers.

6 All the forces in the attacker's second wave arrive at the beginning of turn 4, and move on from the attacker's board edge.

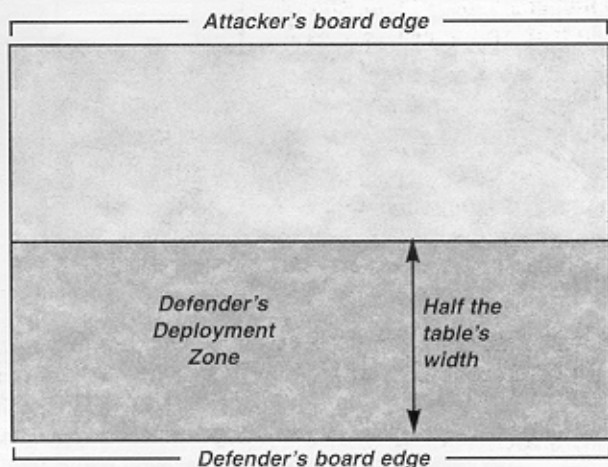

MISSION OBJECTIVES

The attacker must eliminate the rearguard forces quickly and keep the momentum of his advance going. The defender must stall the attack for as long as he can.

If the defender has any units over half strength, or vehicles still able to fire a weapon, within range of any enemy at the end of the game then he wins. If he does not then the attacker has won.

RESERVES

See the scenario special rules section for how to place Deep Strike units.

GAME LENGTH

The game lasts for a random number of turns (see the scenario special rules).

LINE OF RETREAT

Any unit which is forced to fall back will move towards its own long board edge by the shortest possible route, using the normal Fall Back rules.

D BREAKOUT MISSION

ATTACKER'S OVERVIEW

Your forces have been surrounded and are facing annihilation unless you can break through the enemy lines. You must act quickly to escape before your foes can move up overwhelming forces to annihilate you.

DEFENDER'S OVERVIEW

You have an enemy force trapped and surrounded. Your force has been ordered to contain this pocket of resistance whilst forces are massed to wipe them out.

SCENARIO SPECIAL RULES

None.



SET-UP

1 Number the short board edges 1 and 2.

D The defender must split his force into two parts, one for each short board edge. Each force must include whole units, units may not be split between forces. Number these forces 1 and 2 to correspond with the short board edge numbers.

Forces chosen from the Elites section of the defender's army list do not have to be allocated to a force, they can be positioned in either force later.

A The attacker deploys all his forces in his deployment zone.

4 The defender deploys his units. They may not be positioned within 18" of any enemy unit and must be closer to their allocated short board edge than the opposite short board edge.

5 The defender now deploys his Elite units, they can be placed anywhere on the board, but not within the 18" of any enemy unit.

6 Roll a D6: on a 1 the defender gets the first turn, on a 2 or more the attacker gets the first turn.

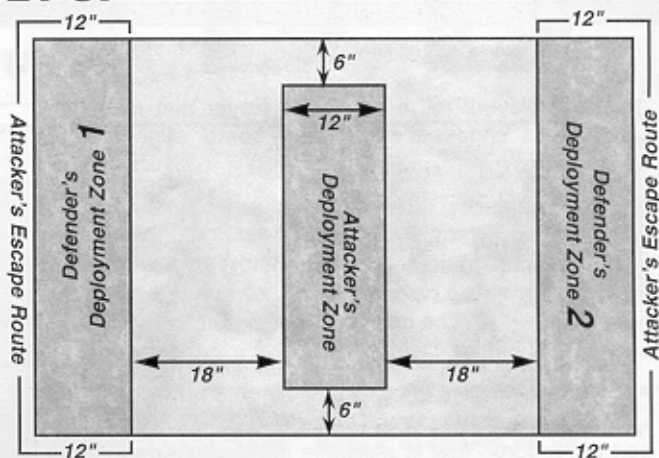

MISSION OBJECTIVE

The attacker must get as many units off the board as he can. If he manages to get half or more of the units in his force off either of the short board edges, or up to 12" along the long table edges from each corner, then he wins. A unit with any survivors or a damaged vehicle still counts towards this.

If the attacker does not manage this then the defender wins.

RESERVES

None.

GAME LENGTH

The game lasts for six turns.

LINE OF RETREAT

Defending units which are forced to fall back will do so towards the closest short board edge. Attacking units which are forced to fall back will do so towards the centre of the board. All units use the normal Fall Back rules and move along the shortest possible route. Once they reach the centre of the board they will automatically regroup regardless of numbers remaining, enemies in close proximity or anything else (the situation is desperate!).

⚡ BLITZ MISSION

ATTACKER'S OVERVIEW

You have been chosen to spearhead a new offensive. Your forces must quickly smash the foe aside so the units behind you can drive deep into enemy territory. You will commit a strong force to attack along a narrow frontage. Expect strong resistance from a well dug in enemy, whose reserves will not be far away.

DEFENDER'S OVERVIEW

The troops under your command have established a good defensive position, with plenty of reserves available. Your task is to stall any enemy attack long enough for these reserves to move up and support you.

SCENARIO SPECIAL RULES

Blitz missions use the *Deep Strike*, *Fortifications*, *Hidden Set-up*, *Infiltrators*, *Obstacles*, *Preliminary Bombardment*, *Reserves* and *Victory Points* scenario special rules.

SET-UP

1 Roll randomly for which short board edge will be the attacker's table edge.

2 The board is divided lengthways into thirds as shown on the map.

3 The defender may place his fortifications and obstacles in the central third of the board – the Fortification Zone.

4 The defender deploys any of his Troops, HQ and/or Heavy Support units in the Fortification Zone using the Hidden Set-up rules. He does not have to set up all these units but he must set up at least one. The rest of his forces are in reserve.

5 The attacker deploys all his forces in No Man's Land, up to 6" from his table edge (except for Infiltrators which may be deployed up to 18" onto the table, and Deep Strike units which may be held in Reserve).

6 The attacker resolves his preliminary bombardment.

7 The attacker gets first turn.

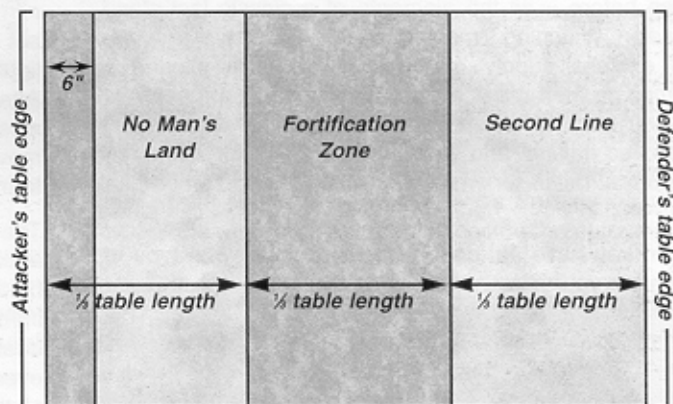

MISSION OBJECTIVES

The attacker must smash through the defender's lines, crossing razorwire, tank traps and minefields in the process. He must keep advancing at all costs, getting as many units as he can into the defender's Second Line. The attacker gets +300 victory points for each unit he has in this section of the board at the end of the game.

The defender must hold his line and stall the enemy thrust. The defender gets +150 victory points for each enemy squad or vehicle in No Man's Land at the end of the game. If a unit straddles two areas, count it as being in the one further from its table edge.

At the end of the game add up victory points. If the attacker has more victory points then he has pushed the enemy aside and created a gap for his following forces to exploit. If the defender has more victory points then the spearhead has been blunted, his lines have held long enough to be reinforced before the next attack.

RESERVES

When the defender's reserves arrive they move on from his board edge. Attacking Deep Strike units appear as per the scenario special rule.

GAME LENGTH

The game lasts for six turns.

LINE OF RETREAT

If any units are forced to fall back they will do so towards their own board edge by the shortest possible route.

DESIGNING YOUR OWN MISSIONS

The missions we have included in this book give a good idea of the variety of different Warhammer 40,000 games you can play. Of course, you can always make up missions of your own, and this has the advantage of them being well suited to the kind of scenery, miniatures and players you have access to.

Inspiration for missions can come from many different places – a good source of ideas is actual historical battles. History is packed with battles large and small, each with their own unique objectives and background. For example, in the battle of Rorke's Drift a tiny contingent of British infantry fought a desperate battle to avoid annihilation at the hands of a huge Zulu army which had wiped out a much larger British force just days before – all the elements of a classic last stand mission. Watching films and reading books will give you an endless supply of ideas. If you are playing a campaign then missions will often suggest themselves. A river may be an important feature on the campaign map, so taking and holding a bridge will make an important battle for which you might want to write your own mission.

Once you have an idea you must decide what type of scenario your mission will be. Let common sense guide you in this. If the mission involves a stand up fight then it is probably a Battle or Breakthrough scenario, if it is a sneak attack then it is likely to be a Raid. If you find it difficult to fit your mission into one of these categories then it is probably a standard mission. Alternatively, you can just create your own force organisation chart for your new mission.

The next thing to consider is which scenario special rules to use. Scenario special rules range from Random Game Length to Preliminary Bombardments to Hidden Set-up and Sentries. These are the building blocks of your mission, and which special rules are appropriate to your mission is up to you to decide. Be sensible here and resist the temptation to use too many special rules because they can slow your game down a lot. Use them to add character to the battle instead.

You will also have to consider whether special troop types have any advantage in this mission. Again, be careful here as the advantages gained can affect the battle drastically. A good guide for using Deep Strike

troops is that if the defenders are in a static position which would have been well scouted before the battle then the attackers are likely to be able to co-ordinate their attack with Deep Strike troops. Likewise, if the defender is holding a static position then Deep Strike troops may well be in reserve waiting to come to their aid. Deep Strikes would be harder to co-ordinate if either side is on the move, sneaking about in enemy territory or cut off from their own lines.

Use the missions in this book as a template for writing your own. You will need to note down how to set up the troops, remembering that some of them might be in reserve. It is useful here to use the categories of troop types as a guide. Maybe this is a battle where a command bunker is under attack, so the defender must set up his HQ units and his Troops, or perhaps it is a lightning strike, so the attacker can only deploy his Fast Attack units. If some units are in reserve then think about where the reserves will move on from. Perhaps they are moving up behind the initial wave, or have been ordered to make a flank attack.

The battle also needs an objective. This can be a sudden death victory condition – if you destroy this bunker or kill a certain character then the battle ends immediately, for example. The alternative to a sudden death objective is to use victory points. A clear objective, even if it is only annihilate the enemy, is important, after all this is the reason the battle is being fought.

In your mission both sides will require a line of retreat. This is the direction that troops who are falling back will move. Generally this will be towards their deployment zone, but in special circumstances this could be changed. What if the defenders are surrounded, where do they run to?

The last thing to consider is special rules which are specific to this battle. Perhaps a bridge needs blowing up, in this case you will need to detail how this can be done. Do all the attacking troops carry demolition charges or only the commanders? Can heavy weapons be fired at it to blow it up? Is a river fordable or toxic, are there lots of unexploded shells littering this battlefield, or are there dangerous reptiles lurking in the jungles ready to leap out and attack either side? There are lots of entertaining special circumstances you could include in your mission, but again beware of using too many. Do not forget that the main reason you are writing a mission is to make a fun and entertaining game for both players.

Last of all, if you do write an entertaining mission that you and your friends enjoyed playing, then send a copy of it into the Citadel Journal or White Dwarf magazine. If it's good enough you could get your name in lights (well, in print anyway)!

**A good soldier obeys without question.
A good officer commands without doubt.**

Tactica Imperium

FIGHTING A WARHAMMER 40,000 CAMPAIGN

Once you have become familiar with the Warhammer 40,000 rules and played a few one-off games, you may want to start linking your battles together and developing some continuity for your army. This is called a campaign: a series of battles linked together by a story and by the forces fighting it. Wars are rarely resolved by a single battle, and even very large battles are preceded by smaller actions between scouts and lighter troops. After a battle there are always the mopping up operations as the vanquished side attempts to escape. With a campaign you can create this story around your own army, seeing it triumph in battle after battle or thwarted in its every endeavour.

DIFFERENT TYPES OF CAMPAIGNS

Fighting a campaign is very rewarding and great fun, and there are many ways to approach it. There are several common types of wargames campaign.

NARRATIVE CAMPAIGN

A narrative campaign is a series of battles linked together by a story. This story is often mediated by an independent referee, who can introduce special scenarios, victory conditions, strange events, extra rules and so forth.

For example, the players want to play a narrative campaign detailing an Ork invasion of an Imperial world. The first battle takes place as the beleaguered defenders of the space port are attacked, when the Orks try to capture the port so they can get their heavy equipment and vehicles to the surface. The Orks win, so the referee decides they can use more vehicles and Dreadnoughts in the next battle because they can use the space port landing pads. In the next game, the Orks go on the offensive and attempt to break through the defenders now encircling the space port. Say they win again, the referee decides that the Governor's palace is now under threat from the Ork invaders and a large battle takes place between the Governor's guards and attacking Orks. The Imperium win this time so the referee allows the Imperial player to attempt to assassinate the Ork Warlord leading the invasion, and so on. The campaign continues like this until the narrative suggests an ending.

It may even be the case that a battle suggests various different courses of action. Rather than the referee arbitrarily deciding which battle is fought next, they may present one or more of the players with some options – does the Ork player want to drive for the Governor's palace or consolidate their hold on the space port? Does the Imperial player want to counter-attack immediately

or prepare their defences? What the players opt for will alter the course of the campaign, so that strategic decisions, in combination with winning battles, can affect the outcome.

Of course, a referee isn't essential in a narrative campaign – the players can discuss the various options and decide between themselves on the course of action. A narrative campaign, more than any other campaign, is more than just winning battles – it's an exciting story where the results of your battles decide the outcome.

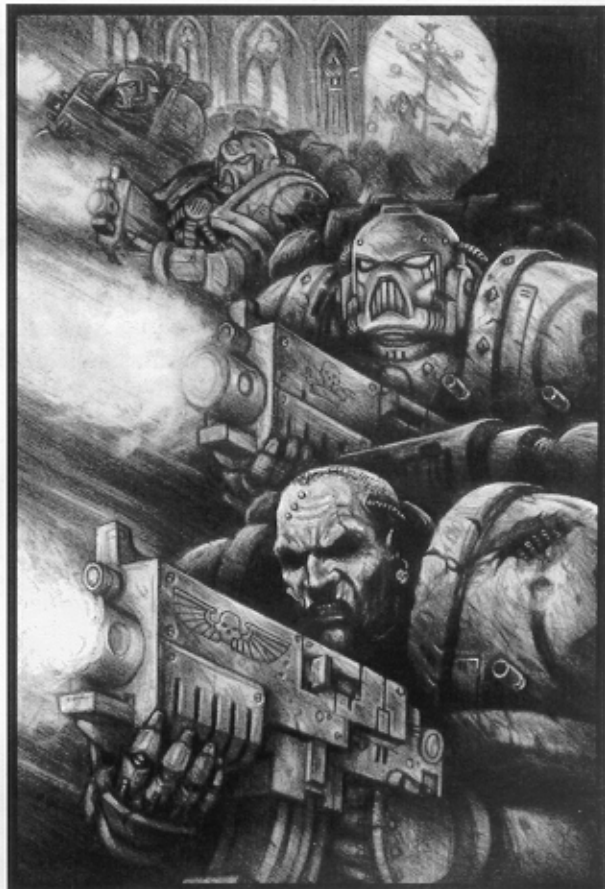

LADDER CAMPAIGN

In ladder campaigns the players agree to play a pre-set series of battles, with each battle affecting the outcome of later battles. Unlike narrative campaigns which let each battle's outcome drive the story, the links within a ladder campaign tend to be predetermined, so you don't need a referee.

Using the above example, the players may decide beforehand to play these battles: *Defend the Space Port*, *Break Out*, *Governor's Defence* and *Assassination*. Before any of the battles are fought the players decide what the benefits or penalties for winning and losing these battles will be. The winner of the first battle may have reinforcements from orbit in the form of more Heavy Support. For the second battle, the loser may have some of their forces delayed in reserve for the later battles, as they attempt to destroy their enemies around the space port. In the third battle, the victor will score a boost in morale which allows all his units to add +1 to their Leadership, and the final battle determines who is the winner of the whole campaign.

MAP CAMPAIGN

A map-based campaign uses a map (surprise, surprise) to control the action of each force under a player's control. There are 'campaign turns' between battles, in which the players move their forces about on the map. When armies move into each other on the map, a battle is fought to determine the outcome of the encounter. Map campaigns often include special rules for such things as supplies, reinforcements and scouting forces, so perhaps a unit's movement would be restricted if it didn't have enough fuel for its vehicles. Map-based campaigns often turn into games in their own right and actually fighting the battles on the tabletop becomes of secondary importance to out-maneuvring your opponent on the campaign map. You don't need a referee for a map-based campaign, but it helps to have an independent arbitrator who can force the protagonists to fight their tabletop games in time for the next campaign turn, and impose forfeits if players do not. The best asset a map campaign can have is very dedicated players, who will play their battles before the next campaign turn starts.

In battle you must husband your resources carefully, sacrificing as little as possible for the greatest gain.

Victory is important, but winning a battle is of little value if by doing so you lose the war.

Tactica Imperium

TREE CAMPAIGN

A more elaborate form of ladder campaign is known as a tree campaign. In a tree campaign, battles are organised by a pre-drawn flow diagram with the results of each battle giving predetermined advantages in following battles. Each time a battle is fought the diagram will tell you which mission to fight next by following the correct path. The longer the campaign the larger the diagram will need to be. In this short example there are only two battles to fight, and winning or losing determines whether you achieve a major victory in the campaign or are crushed by your foes.



In more involved campaigns you could also include paths on the diagram that looped back, or sub-plots which branched off the main tree. You could also experiment with allowing victors a few extra points in their armies after winning a particularly important battle, or perhaps losing a fight for control of a tank factory might mean less Heavy Support choices next time. The amount of variation depends only on your campaign background and your imagination.

RUNNING A CAMPAIGN

Campaigns offer a lot more fun and challenges to players than constantly playing one-off battles where the outcome does not have any effect on the next battle you fight. Campaigns are not just about organising battles, they are also about developing your own army and characters and giving them some history. This is where the experience points system comes in, which is discussed in the next section.

CAMPAIGNS AND EXPERIENCE

Troops who fight over a protracted campaign, and survive to tell the tale, will build up their skills and fighting ability. Raw recruits, new to the horrors of warfare in the 41st millennium, are less resolute in the face of enemy fire, whereas units who have many battles and victories under their belts will become hardened fighters with many specialist skills. The following system allows your army to build up experience by fighting and winning battles, destroying enemy troops and generally learning how to fight.

UNIT ROSTER CARDS

If you wish to play in a campaign, it is a good idea to fill out a unit roster card for each squad and vehicle in your army (unit roster cards like the one below can be photocopied from the examples included in the Appendix). This card then becomes a record of the unit over your following battles. As units fight they will lose or gain experience and any new skills or abilities they gain or penalties they suffer from are noted on the card. If you make any changes to the composition of the unit you alter the card to show this, and make up new roster cards if you add any more units to your army.

When you come to choosing your army for a battle, rather than picking it from scratch from the army list each time, you choose which units to use from your file of rosters. So, for example, if you are fighting a battle that allows you to field three Fast Attack choices, rather than picking fresh units from the army list, look through the roster cards you have filled in for your Fast Attack units

For every battle honour, a thousand heroes die alone, unsung and unremembered.

and decide which of these you want to use. Keep choosing units from your file of rosters until you have the army you want. Think of your unit roster cards as building bricks which you can combine together in different ways to achieve a varied army choice.

The main point is that individual units become regular components of your army, rather than being one-off choices for a specific battle. Some of them will be tried and tested veterans, whilst others will have yet to prove their mettle. In this way, over a number of battles your army will start to develop its own character with its particular strengths and weaknesses, which will differentiate your army from others, even of the same race.

The top line is for basic information which you can use when you're building up your force from your collection of army cards.

Use the middle section to record the profiles of the unit's warriors and vehicles. Dreadnoughts can use either section – put their extra stats under 'Special'.

Put the unit's weapons' profiles here for easy reference during play.

UNIT NAME:				UNIT TYPE:						POINTS COST:	
No.	TROOP TYPE	WS	BS	S	T	W	I	A	Ld	Save	Special
No.	VEHICLE TYPE	BS	Armour: Front			Side	Rear	Special			
WEAPONS		Range	Strength	AP	Shots	Special Rules					

Use the space on the back for noting experience, battle honours and the unit's history.

EARNING EXPERIENCE POINTS

Units can earn experience points in a number of ways (and also lose them if they perform badly). The chart below lists the different ways in which experience can be gained and lost.



TRANSPORT VEHICLES

A transport vehicle which is chosen as part of a squad (a Space Marine Rhino or Imperial Guard Chimera, for example) cannot gain Battle Honours of its own (who ever heard of an Elite Chimera?). Transport vehicles which are chosen as a self-contained unit (like Eldar Falcons and Space Marine Land Raiders) earn experience just like any other vehicle, and roll on the Vehicles table for any Battle Honours they gain.

INDEPENDENT CHARACTERS

Some characters do not have to be with a particular squad, such as Eldar Phoenix Lords and Imperial Guard Commissars. These characters earn experience points in the same way as other units, and if they are fighting as part of a squad they will receive any experience points the squad earned while they were a part of it. However, they make rolls for Battle Honours separately from any squads they joined and so may gain a different skill.

All of these experience points awards are cumulative with each other. For example, a unit is on the winning side and earned 100 experience points by achieving the mission objectives, but was reduced to half strength. The unit would have the following experience points:

Fighting	+100
Winning	+100
Achieving the mission	+100
Half strength	-D3x100

If the D3 roll came up as a 2, this would be a total of $100+100+100-200=100$ experience points earned.



EARNING EXPERIENCE

Experience is earned as follows:

Fought in battle: +100

For every battle the units takes part in, it earns +100 experience points.

On winning side: +100

If the unit is on the side that won the battle it gains +100 experience points.

Achieving Objectives: + variable points

This is equal to the number of victory points the unit has earned for achieving mission objectives during the battle. For example, over half strength units which get into the enemy deployment zone during a Recon mission score 100 victory points (+100 experience). See the separate box for details of missions which do not award victory points for achieving mission objectives.

Broke enemy in an assault: +100

If the unit forces an enemy unit to fall back after an assault, it gains +100 experience points. If it wipes out an enemy in an assault (ie there were none left to break!), or destroys an enemy vehicle, the squad earns +100 experience. A squad does not earn +200 experience for breaking an enemy in an assault and then wiping them out with a sweeping advance – it's one or the other.

Reduced to half strength/vehicle damaged: -D3x100 from experience earned

If the unit is reduced to 50% or less of its original numbers, or is a vehicle that suffers lasting damage (ie is immobilised or has a weapon destroyed), then it loses a number of experience points equal to a roll of a D3 multiplied by 100. This is deducted from the experience earned from this battle and cannot reduce the squad or vehicle below the experience it had prior to the battle.

Wiped out/vehicle destroyed: -100 from total

If the unit is wiped out, or falls back off the table, or is a vehicle that is destroyed, then it gains no experience from the battle at all. In addition, the unit loses -100 experience points from its total at the start of the battle.

Acting beyond the call of duty: +D3x5

At the end of the battle, each player can nominate one unit in his army that he thinks has performed particularly admirably. This unit receives D3x5 experience, and a nice shiny medal/squig/gemstone or whatever.

EXPERIENCE IN DIFFERENT SCENARIOS

As well as the experience modifiers already given, units can earn or lose experience by performing well or badly in particular scenarios. Details of these are given below.

Cleanse/Night Fight: Any unit which claims an uncontested table quarter at the end of the battle earns +50 experience points.

Rescue: +100 experience if the unit is in possession of the objective at the end of the battle.

Take and Hold: +100 experience if the unit claims the objective at the end of the battle.

Meat Grinder: In a one-off game, it is easier to think of 'recycling' units as part of the sustained assault. However, in reality the unit isn't instantly brought back to full strength and sent in to fight again, but is replaced by another unit from behind the front line. If you are playing using experience, a unit which is wiped out loses experience points as normal. It does not come back on to the table, but is replaced by another squad. It may be just a case of filling in a new unit roster card each time a unit is recycled, or you may want to devise a system of bringing on fresh troops up to the points value of the troops that are being replaced. As you can probably tell, a Meat Grinder is gruelling affair for the attackers and it may be that you'll not want to commit your most experienced troops to this near-suicidal battle!

Sabotage: +100 experience if the unit destroys the objective.

Breakout: +100 if the unit manages to leave the table off a short table edge.

EFFECTS OF EXPERIENCE POINTS

As a unit gains or loses experience and its status changes, it will gain certain benefits or suffer penalties. For every 1,000 experience points a unit earns, it gains a Battle Honour. Each Battle Honour is represented by a particular skill or ability, depending upon the type of unit. For every Battle Honour a unit gains, make one D6 roll on the appropriate Battle Honours table (infantry, bike/cavalry and vehicle tables are given later on). If you roll a Battle Honour the unit has already you can choose one of the other Battle Honours on the list instead.

If a unit loses a Battle Honour due to its experience being reduced, randomly determine which one is lost.

POINTS COST

As a unit's experience changes, the points value it is worth will also change to reflect their expertise and availability. For every whole 1,000 experience points a unit earns, its points value is increased by 10% (rounding up). So a unit with 1,000-1,999 experience has its points increased by 10%, 2,000-2,999 by 20% and so on. This is demonstrated in the examples below.

Example 1

Unit type	Basic points cost	Points per 1,000 Experience (10%)
10 Imperial Guard	50	+5
10 Eldar Guardians	80	+8
10 Orky Bommas	100	+10
10 Space Marines	150	+15

Example 2

Unit type	Points cost for experience			
	0 -999	1,000 -1,999	2,000 -2,999	3,000 -3,999
10 Imperial Guard	50	55	60	65
10 Eldar Guardians	80	88	106	114
10 Orky Bommas	100	110	120	130
10 Space Marines	150	165	180	195

BECOMING ELITE

A unit from the Troops, Heavy Support or Fast Attack sections of the army list with 3,000 or more experience points becomes Elite. These specialised troops are often called upon to fight in other battles and their availability is limited. To represent this, Troops, Fast Attack and Heavy Support units with 3,000+ experience count as Elite troops for choosing the army, deployment and so on in subsequent battles.

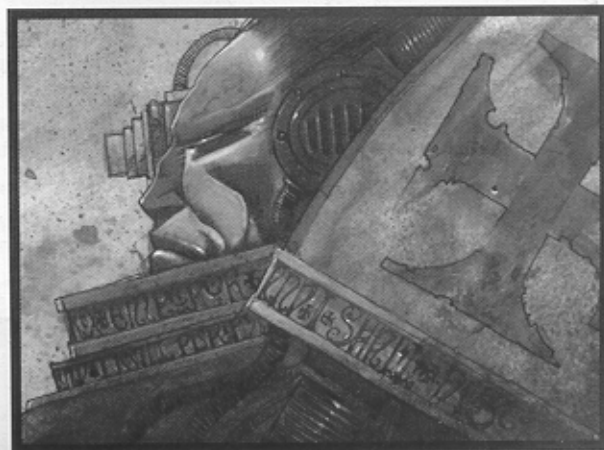



EXPERIENCE LOST FOR CHANGES

Change made

Change in numbers

Weapons/equipment change

Transport change

Change of leader

Experience lost if Leadership test failed

-100 experience for each squad member added or taken away.

-100 experience for each weapon/piece of equipment changed, taken away or added.

-100 experience for a transport vehicle added or taken away.

-D3x100 experience for changing the squad leader (adding or taking away an Exarch, Veteran Sergeant, Chaos Champion, etc).

CHANGING A UNIT

A unit gains experience by working together as a team and growing more familiar with its weapons. If new recruits are brought in, the unit's experience will deteriorate as the overall skill level is brought down. This is represented by losing experience points when the unit is reduced to half strength or wiped out.

However, if a unit is issued with new equipment or otherwise has its role altered it may have to spend some time regaining its experience, although it is also possible for a unit to be changed and the fighters to take to their new role without any loss of experience. For every change made to a unit (each new member, different leader and so on), make a standard Leadership test. If the test is passed, the change has no effect on the unit, if the test is failed the unit loses a number of experience points as indicated on the chart above.

For vehicles use the Leadership characteristics listed on the table to the right.

Example 1: Squad Vengeaus is a Space Marine Tactical squad with a Sergeant and 6 Space Marines. They have 885 experience points. The Space Marine player decides he wants to upgrade them so that they are ten strong and carry frag grenades. This means adding three members (count as three changes) and one

VEHICLE LEADERSHIP VALUES

Chaos	8
Dark Eldar	8
Eldar	8
Imperial Guard	7
Orks	7
Sisters of Battle	8
Space Marines	8

weapons change. This potentially reduces their experience by (4x100) 400 experience unless they can pass four Leadership tests. The unit passes three of the tests (being well trained Space Marines), leaving them with only a -100 experience penalty. Their experience is therefore reduced to 785 points.

Example 2: The Bonepounder is an Imperial Guard Leman Russ battle tank. It is armed with its standard battlecannon and a hull-mounted heavy bolter and has 945 experience points. The Imperial Guard player wants to up-gun the Bonepounder and so swaps the heavy bolter for a lascannon (1 change) and fits heavy bolter sponsons (1 change). This means that its experience will be reduced by 2x100=200 unless it can pass two Leadership tests. Unfortunately, the Imperial Guard player fails both of the tests, leaving the Bonepounder with 745 experience, but some more guns!

Many worlds were first settled by humans during the time of the Stellar Exodus almost twenty-five thousand years ago. So prolific were the colonies seeded by mankind that the Imperium is constantly rediscovering human civilisations which have been isolated for millennia, sometimes since before the time of the Emperor himself. The existence of human worlds and the Imperium often comes as something of a surprise to the inhabitants of these planets.

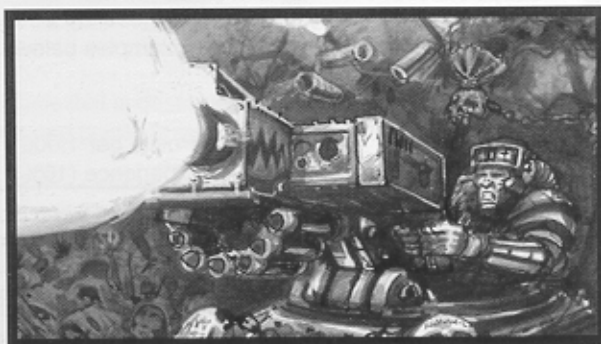



INFANTRY BATTLE HONOURS

D6 Roll Skill

- 1 **Street Fighters** – If the unit is in cover, then its saving throw for cover is increased by 1 point (normally 4+ rather than 5+).
- 2 **Hardened Fighters** – The unit may ignore negative modifiers for Morale checks and tests for regrouping (eg 50% casualties). In effect, the unit will always use its standard Leadership for these tests.
- 3 **Steadfast** – The unit may attempt to regroup even when below 50%.
Space Marines re-roll this skill.
- 4 **Guerrillas** – The unit rolls an extra D6 when moving through difficult terrain, and picks the highest for its movement as usual.
Units with jump packs re-roll this skill.
- 5 **Tank Hunters** – The unit always passes any tests for tank shock and adds +1 to all armour penetration rolls.
- 6 **Counter-attack** – If a close combat involving this unit is a draw, the side with this unit automatically wins the tie-breaker. If both sides contain a unit with the Counter-attack skill, then roll off as normal.



BIKE/CAVALRY BATTLE HONOURS

D6 Roll Skill

- 1 **Skilled Riders** – The unit may re-roll any 1s rolled for difficult terrain tests. The second roll counts, even if it is also a 1.
- 2 **Rapid Deployment** – After both armies have been deployed the unit may move an additional 6"; treated just like normal movement.
If the unit starts in Reserve, then you may add +1 to all rolls for that unit when testing to see if they turn up.
- 3 **Hardened Fighters** – The unit may ignore negative modifiers for Morale checks and tests for regrouping (eg 50% casualties). In effect, the unit will always use its standard Leadership for these tests.
- 4 **Resolute** – The unit may re-roll any failed Morale checks. The second roll stands, even if it also fails.
- 5 **Counter-attack** – If a close combat involving this unit is a draw, the side with this unit automatically wins the tie-breaker. If both sides contain a unit with the counter-attack skill, then roll off as normal.
- 6 **Lightning Charge** – If the unit makes an assault into the enemy and wins, the enemy suffers an additional -1 modifier to their Leadership for the subsequent Morale check.



VEHICLE BATTLE HONOURS

D6 Roll Skill

- 1 **Terrifying** – Tanks: Any unit testing for tank shock inflicted by this vehicle suffers an additional -1 modifier to its Leadership.
Other vehicles: the vehicle causes tank shock if it moves through the enemy, just like Tanks.
- 2 **Fast** – The vehicle now uses the rules for Fast vehicles. However, it must still be stationary to fire ordnance. Vehicles which are already Fast re-roll this skill.
- 3 **Reinforced armour** – Reduce any damage rolls made for the vehicle on the Glancing Hits table by -1, treating results of less than 1 as 1.
If the vehicle is open-topped then this reinforced armour bonus will negate the normal +1 modifier when rolling on the Glancing Hits table. Penetrating Hits still add +1 for open-topped vehicles with reinforced armour.
- 4 **Tank Hunters** – The vehicle may add +1 to all armour penetration rolls.
- 5 **Hardened Crew** – The vehicle treats all 'Crew Stunned' results on the damage tables as 'Crew Shaken' (result 1-2 on the Glancing Hits table).
- 6 **Skilled Gunnery** – Nominate a weapon at the start of the shooting phase. You may re-roll any missed to hit rolls with this weapon that turn. For ordnance, this allows you to re-roll the Scatter dice. You can only re-roll the dice once, so there is no benefit from this skill for linked weapons. You may only re-roll one weapon in any turn, though you may change which weapon you fire each turn.